

The book is the collection of papers that have the common idea of understanding of the synthesis of the universal physical and spiritual laws which have not been formalized so far but which the mankind uses through the science, religion and art united by the concept of Culture. It is just a small brick of the building of the commanded synthesis about which Patriarch Kirill dreams and Metaknowledge says (Agni Yoga, Theosophy and Temple of the People). It is the noospheric area the discovery of the roots of which might take millenniums. The Chinese say that any long way starts with a small step which has been done in the book. We will be happy if it helps somebody find their way to the Truth which cannot be covered by any philosophy, religion or science. It is a joint work; the co-authors's names are given and the author appreciates them. Practically all the papers were presented and discussed at international conferences. I would like to thank Alma Mater – Donetsk National Technical University where the projects were fulfilled, the University, Faculty and Department's administration, and my family for their patience and support in my research.

The Universe Ethic Algorithms. S. Dzhura



Сергей Георгиевич Джура

# The Universe Ethic Algorithms

Sergey Georgievich Dzhura



Academician at International Academy of Ecological Science and Safety Spb; Ph.D., Associate Professor of Department of Electric Power supply of Industry and Cities at Donetsk National TEchnical University (DonNTU); Vice-Director of Institute of International Cooperation; URL: [http://iic.dgtu.donetsk.ua/english/ovs/sergey\\_dzhura.htm](http://iic.dgtu.donetsk.ua/english/ovs/sergey_dzhura.htm)

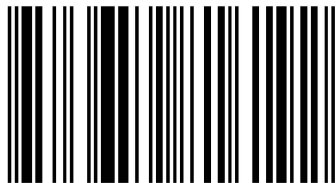

978-3-659-81619-2

Джура



Sergey Georgievich Dzhura

The Universe Ethic Algorithms

**Sergey Georgievich Dzhura**

**The Universe Ethic Algorithms**

**LAP LAMBERT Academic Publishing**

**Reviewers:**

*S.R.Ableev, Doctor of Philosophy International Non-governmental Association "Ethic and the Future Science" (Moscow)*

*I.P. Podlasy, Doctor of Pedagogic, Professor, the international expert in education*

*L.N.Yasnitski, a professor of the Department of Applied Mathematics and Informatics of Perm State National Research University, the Chairperson of the Perm Department of the Academic Board of the Russian Academy of Science in Methodology of Artificial Intelligence, Doctor of Science.*

*V.A.Goltsov, Doctor of Science (1973), Professor (1975), an academician of the International Engineering Academy (1990), a member of the Board of Directors of the International Association of Hydrogen Power Engineering (the USA), the Head of the Department of Physics of DonNTU, the Education Worker Emeritus of Ukraine.*

**Dzhura S.G. The Universe Ethic Algorithms / S.G.Dzhura – Saarbruken: LAMBERT Academic Publishing, 2015. – 674 p.**

Dear Reader, It is the work for the Man of the Future and it deals with the Ethic Algorithms of the Future Science. It is a ready Doctoral dissertation which I have not managed to defend so far as there are no relevant boards to do it at. The necessary academic councils are to be established. The book is the specific public defense of the dissertation. It is a collection of papers in which the author shows the application of the research new synthetic method. The method has not been recognized by the modern science yet, though its roots go in the old days. Different aspects of its application in pedagogic, philosophy, power engineering and artificial intelligence are examined.

All the papers were presented at various international interdisciplinary conferences in different world countries, were awarded by diplomas and got positive references from experts. They are presented in the logical order in the book. There are some repetitions but they just emphasize the significance of application of the ethic algorithms in science.

The book came out in the year of the 700<sup>th</sup> anniversary of St. Sergius of Radonezh, the 350<sup>th</sup> anniversary of the Treaty of Pereyaslav, 140<sup>th</sup> anniversary of N.K. Roerich, 135<sup>th</sup> anniversary of E.I. Roerich, and the 110<sup>th</sup> anniversary of S.N. Roerich.

The book is to be read by the heart language.

There is every reason to consider the work to be one more brick of the building of the Science of the Coming Jerusalem.

ISBN 978-3-659-61003-5

## Contents

1. Philosophical understanding of algorithms and methods of decision making .....	3
1.1. Heading to forming of the planetary civil society.....	3
1.2. Search of meaning of life: aspects of synthesis of natural science and liberal arts .....	19
1.3. Internet-integration as a stage to the noospheric thinking ....	26
1.4. Social Aspects of the virtual reality .....	36
1.5. From noosphere to ethikosphere .....	45
1.6. Heading to homo noosphericus .....	55
1.7. Multivariable consciousness .....	74
2. Risks of the civilization .....	92
2.1. Today's riskological challenges.....	92
2.2. Esotericism of the idea of time and timely risks of the modern civilization .....	104
2.3. Power risk control (to the 150 <sup>th</sup> anniversary of Nikola Tesla).....	114
3. Energy of the future .....	123
3.1. World-outlook characteristics of paradigm change in energy .....	123
3.2. Heading to N.Tesla's phenomenon solution (interdisciplinary approach) .....	132
3.3. Introduction to metaenergy.....	138
3.4. Quantum energy outlines .....	148
3.5. Multidimensional energy .....	160
4. Pedagogic algorithms and their implementation.....	171
4.1. Philosophical approach to the analysis of modern pedagogic .....	171
4.2. Distance education of the future: approaches made through the retrospective analysis of the philosophical thought .....	182
4.3. Distance learning characteristics on the development noospheric stage .....	221
4.4. The outlook of application of artificial intelligence in distance education.....	260

4.5. Taking into account of the cognitive thinking type in distance education .....	268
4.6. Distance education energy and information paradigm .....	272
4.7. Synthesis pedagogic fundamentals.....	288
4.8. Application of neural networks to improve distance education of power engineering students .....	297
4.9. Application of visualization gas-discharge chamber to improve distance learning system for power-engineering students .....	313
4.10. Adaptive training system in professional training of power engineers.....	325
4.11. Programming and pedagogic means Creative Studio PPS 1.0 based distance learning intellectual system for power-engineering students.....	332
4.12. Pedagogic fundamentals of artificial intelligence application in distance education.....	345
5. From information paradigm to its syntagma.....	363
5.1. Information paradigm - open system theory.....	363
5.2. Knowledge new paradigm formation .....	369
5.3. Heading to a new syntagma.....	382
6. The universe ethic algorithms.....	396
6.1. The universe ethic algorithms.....	396
6.2. The crucial role of culture in the noosphere formation.....	419
6.3. Paradoxes of understanding of the Truth in pedagogic research in the context of the metacivilization .....	437
7. Cultural integration of the future Europe.....	460
7.1. Ukrainian idea as an element of the Russian idea in the context of the universal values .....	460
7.2. Commanded synthesis .....	479
7.3. Cultural integration of the future Europe.....	492
Conclusions.....	499
Selected presentations .....	500
The book reviews.....	520

Dedicated to my parents, wife and son,  
As well as to Donesk National Technical University and  
To all my visible and invisible Teachers,  
Whom I make a bow to.

A researcher does not have a  
purpose to get an instant result.  
He works for the future, as a  
sower does. His responsibility  
is to lay the foundation for  
those who will come and show  
them the way. **N. Tesla**

A science is to deal with  
what “can not be”, and  
that “can be” is not a  
science, it is a  
technology.  
**P.L.Kapitsa**

## **Chapter 1 Philosophical understanding of algorithms and methods of decision making**

V.V. Otkidach, S.G. Dzhura, V.I. Chursinov

### **1.1. Heading to forming of the planetary civil society**

The identity of purposes and conclusions, and therefore that of the further way of the mentioned paradigm rapprochement is demonstrated in the paper on the examples of two outlook conceptions (introduction to the modern science and esoteric). The answers to the questions put forward by

one outlook have been developed by the other one. Thus the academician N.N.Moiseyev's maxim "to find a new moral system for the modern mankind" was properly developed in the other outlook conception (Theosophy, Agni-Yoga), which not only contradicts but also supplement with and even outstrips the things that have been discovered by the traditional science today.

The authors give examples of two outlook conceptions (introduction to the modern scientific /1/ and esoteric /2/) to show the identity of goals and conclusions and, therefore, further rapprochement of these two paradigms. The answers to the questions put forward by one outlook have been developed by the other one. Thus the author's /2/ maxim "to find the new moral system for the modern mankind" is perfectly developed in the other outlook conception (Theosophy, Agni-Yoga) which doesn't contradict everything discovered by the traditional science. More than that, it supplements it and goes much further.

**Introduction to the problem's topicality.** We fully agree with the words of the academician N. N. Moiseyev according to which "the possibilities of the consuming society – the civilization originating from the neolitical revolution- are spent or are close to be spent. All good the society had been able to give people was already got, and now the mankind is on its way to the epoch of qualitative change of the character of its development. If to use the dynamic system theory language the mankind is on the way to the bifurcation phase where the public evolution process channel , that is the public evolution development type ( and maybe the anthropogenesis character) itself is changed" /1/.

The academician N. N. Moiseyev is sure that it is necessary to introduce as special course "The Modern Outlook" as the relationships between a human being and the Nature are globally critical at present. The authors of the paper share this opinion. Just for comparison they also turned to the book "The Basics of the New Epoch Outlook" /2/ devoted to the fundamental life problems and the mankind development Though N. N. Moiseyev considers the esoteric knowledge to be "ancient, not completely lost or simply intuitive knowledge or even superstition", he calls it esoteric (and explains: from Greek: "inner"), that is secret, hidden, assigned to esoteric people only (in religious ceremonies, mystical doctrine, magic formulae)). The knowledge came from the human being's history and exists now, in the era of space and nuclear energy. More than that, according to the authors, the knowledge is of great demand now. According to the academician N. N. Moiseyev the relationship between a human being and the Nature occupies a special place in the knowledge. He emphasizes



the beneficial influence of the Nature itself on a human being /1/. The authors of the collected articles /3/ ( by the way, it's the collection of the articles of Russian and Ukrainian scientists supporting both the traditional science approach to the outlook problem and the esoteric conception stated by the Doctor of Philosophy S. R. Ableyev who was the first to defend the dissertation on the Roerich family heritage. He also wrote a striking book which is closely connected with the topic of the paper under discussion /4/ as the author managed to overcome the philosophy eurocentrism and illustrates thoroughly both oriental and Russian conception, cultural and historical phenomenon of the esoteric philosophy. All science conferences "The Ethics and Future Science" traditionally organized and held by the New Epoch journal Delphis are devoted to rapprochement of the outlooks of the science and esoteric conceptions.

. **From «homo sapiens» to «homo noospheres».** At the beginning of the XX century V. I. Vernadsky said that the practical activity of a human being is the main geology forming force of the planet. Now, in the era of the nuclear energy, we know that the human being is able to destroy everything that is alive on the planet. That is why understanding of the potential possibilities of the human being's activities and danger as to the human being's fate being the result of the activities if they are not controlled by the Collective Intellect of the human being is one of the corner stones of the world outlook and, consequently, the education system /1/.

But at the same time it is practically impossible to separate the role of each of the sources and study them separately or ignore their influence on the human being as all of them make up the single human being's inner world and define the human being's behaviour in difficult situations.

V. I. Verndadsky's philosophy is as follows: the more destroying are the forces the mankind possesses the more perfect the mechanism of social control over these forces should be. It is impossible to make this control perfect if there is no philosophical platform which can appear in the frames of the noosphere theory. To create this theory is the first and foremost task of the science of the XXI century /5/.

The primacy of the material comforts is the dead-end way of technical civilization. The noosphere's ideals mean the primacy of the cultural wealth over the material comforts, personality freedom from, first of all, the economic pressure and unfair social system.

The human being should have, like V. I. Vernadsky did, limited material and unlimited cultural needs. The wise ideas of grand V. I. Vernadsky are very topical today: "You can't put off taking care of everlasting and grand for the time when the possibility to meet the

elementary needs will be reached by everybody. Otherwise it'll be too late. We'll hand in the material comforts to the people whose ideal will be "bread and spectacle". They would only like to eat, drink, make love and do nothing. Can the teacher be satisfied bringing up the Skalozubs, Molchanovs, greedy for money bankers, corrupted free-livers, gluttons, and selfish people /6/?

The term «homo noospheres» was introduced by a group of authors /7/. The academician A. A. Yashin says: "The modern Russian scientist, philosopher and cosmos supporter V. P. Kaznachejev, a recognized successor of V. I. Verndadsky's doctrine on noosphere puts ahead the problem of vectorization of the movement of the summarized intellect of the Earth planet : the intellect implemented into the culture, cultural aspiration, science and technical progress etc."

The vector of the movement of the summarized intellect of the mankind at the moment of change from the «Homo sapiens» to «homo noospheres» should be analyzed /8/. According to the authors of the paper the virtual reality (in literature, mass media, and the Internet) is this summarized expression, the reflection of the collective intellect. It's a separate big topic for discussion. This very component is of great importance as 'the future of the planetary community will greatly depend on the knowledge spreading and character, erudition, culture and ideological universals which are the knowledge consequence and which N. N. Moisejev calls the world understanding. "It is this very component of the outlook that society can influence purposely. The future of the society will depend on its ability to understand and accept the unavoidable taboos, and obey them, but it will not depend on the technique and technology perfection" /1/.

**The necessity of ecological imperative closely connected with the ethical one.**

The system of prohibitions which guarantees the mankind's development stability is implied by this term. Why is it so? While becoming «Homo sapiens» that is being aware of himself like this the human being was able to survive due to the right of the 'wise' which existed along with the right of the 'strong'. According to N. N. Moisejev it was reflected in the first "taboos": "Don't kill!" "Look for your second half next cave" and later on in the system of the "Teacher". It made it possible to create the stronger army and people and to survive. Thus the dispositions perfection ( the idea of 'morality' and later on the "ethics" –morality science- generated from it) helped the human being to survive rather than to kill each other as it happened at the earlier stages ( archeological dig proves it).

The principle “don’t kill!” solved the contradictions between the strongest and wisest in favour of the latter.

When N. N. Moiseyev spells the word “Teacher” with the capital letter he means not a person who teaches other people but the whole system of passing the information to further generations. This system is formed by public institutions. A teacher as a separate person whose occupation is to teach young generation is the most important element of the system of the “Teacher”. This element is based on traditions, legal institutions which provide the bringing up of the future members of the society. Defence of all members of the tribe or family contradicted the relations which traditionally existed in the primitive herd. Really, wise and skilled members of the tribe who provided its welfare were not always the strongest, most courageous and luckiest in the men’s fightings which were preferable under usual species selection. To defend not only females and posterity but also knowledge and skills bearer or those who could bear them were of vital necessity for the herd of the original people ( or primitive horde). According to N. N. Moiseyev the strongest prohibition “don’t kill!” appeared gradually on this basis. As it was extremely important for any human being’s group it became the background for any moral and exists in different forms in the religions of all nations /1/. We would like to state that the concept of the “Teacher” was developed the most completely by the oriental tradition /2/.

The danger of coming back of the New Medieval appeared immediately. “I often call myself a pessimistic optimist as I see the potential possibilities the mankind has. But I’m not sure at all that the mankind will be able to use them and manage the genetic heritage left by the mammoth hunters which lives in us. Once this heritage threw all the achievement of the antique civilization back, immersed Europe into darkness of the Medieval. It’s this heritage that represents itself both in the world and local wars and every day behaviour of the inhabitants of the civilized world /1/. As a matter of fact it is necessary to change the thinking paradigm as we are at the very point of bifurcation from which we can’t return.

The statement made by S. V. Klyuchnikov is quite suitable here. “ It is more important to catch and understand the moral of the forthcoming epoch by separating the main from the secondary. If the individualism – the characteristic absolutely necessary to find the place under the sun - has been constantly cultivated in the human being since Renaissance , the new synthesis epoch gives birth to a new quality which is commonness. It makes the human being feel himself “a single whole”/10/. A number of

projects we are taking part in and being mentioned below reflect this idea. They cover the majority of the books mentioned in the papers.

**The Spartans and the modern society helots.** According to N. N. Moiseyev the main danger lies in the idea of the civilization universal paradigm, its forced introducing as a standard, the Protestantism ethics canonization. It can rather be called the “global Americanism” which supports the idea of selection, personal success being its measure. This selection gives oneness and permissiveness the right to exist. This idea came to minds of many Europeans and especially Americans. It gave birth to the conception of the “gold milliard” and other similar ideas which would be a catastrophe for the mankind, the conviction in perfection of the political and economic system accepted by Euro-American civilization being the most dangerous. The future decisions will be made in the spirit of the O’Henry’s story the hero of which killed his companion and justified it by the words: “Bolivar won’t carry two people”.

The possibilities of any civilization based on individualism, idea of oneness, pathological conviction in the personal superiority are spent. They have played their game. This idea is proved by the general falling of the western culture, reduction of the educated people intelligence, absence of the interest in the High Art, everything beautiful created by the mankind and that meets the striving for good, philanthropy, and empathy. This Euro-American culture and the tendency of its development is the distillation of the spiritual degradation peculiar to the civilization which approved capitalism in its modern form.

Modern capitalist system is not interested in the really intelligent and educated society that is aware of the malignancy and danger of the scenario of the public evolution as it contradicts to the momentary advantage of those who “rule the ball” /1/.

The author of the paper /1/ drives to the conclusion that norms of the socialism (though it sounds strange today) should be adopted. But it should be a different stage where the space laws (e.g. will freedom) are not broken. The paradigm of the paper /2/ could be of great help here. As we are people living under the civilization’s crisis we should be aware of the growing practical importance of the ideas of socialism in this interpretation because the civilization is gaining more power and the human being becomes equal to the Nature if not to gods. These ideas are significant for understanding of dependence on the relations with Nature and necessity of the dependence conditions observance. That is why N. N. Moiseyev uses the word combination the “ecological socialism”. According to him the ideas of the socialism are sometimes implemented unconsciously, without any purpose like all the laws of the system of self-organization, like

necessary fulfillment conditioned by the Nature self-organization logic. Maybe it contains the great truth of life as what is called the “socialist idea” is associated with the idea of “good” in the religion of all nations /1/.

It is impossible to implement the ecological imperative without approval of the moral one. The latter contains the main ideas of the Sermon on the Mount, basic ethic norms of the world religions and the desire to create the order on the Earth in accordance with which the people could get earthly blessings and spiritual wealth according to the effort put in. The people should spend the force and skills on the basis of the knowledge which is the public property. Without it the futurity of the human being, if he wants to preserve this name, is hopeless! More than that, the idea of “freedom, equality, and brotherhood” was written on the Theosophy’s banner. What’s the problem then? The problem is in understanding of the situation and making the collective decision.

### **From the Collective Intellect to the Collective Mind and Collective Will.**

Thinking about the collective or artificial intellect and the ways of its creation the person wants to understand how the life was given the intellect, how it appeared in the Nature. The person wonders how the brain, which consists of tens of millions of neurons and capable not only to invent and create but cognize itself appeared from one and maybe and only cell.

Forming of the Collective Mind (Collective Intellect) is analogous to forming of the human being’s brain. The human being’s brain, as well as that of other animals, consists of neurons which are not able to act reasonably on their own. But in their aggregate they give birth to a certain system characteristic which we call thinking. Its studying doesn’t cover the studying of separate neurons as it really is the system characteristic of the neuron aggregate! It doesn’t depend on the people’s will.

The same could be said about the Collective Intellect. It is formed of the aggregate of the individual intellects of some people and minds playing the role of separate neurons in this aggregate. This system (the individual minds aggregate) has characteristics which are not derived from the characteristics of separate minds. It is a system characteristic. Its potential possibilities, which we can’t evaluate today, don’t depend on the will and actions of the people. It is the result of the self-organization. But the possibilities application depends on the civil society features and organization and its Collective Will. The alternatives can be unexpected.

The real informational society could be born. Its Collective Intellect could solve the problems of the co-evolution, organize the society according to that pattern which N. N. Moiseyev called the rationally organized society. But the Collective Intellect could fall into hands of

small number of people who could implement another type of the strategy – the strategy of totalitarianism. The power of the planetary informational system could be used to approve it. It could be used to make zombies out of the “helots” who make up the majority of the planet’s population for them to provide the life to a comparatively small number of the modern democratic “Spartans”. We are now under the influence of the powerful mass media which are concentrated in a small number of hands. May be this fact really is the beginning of the purposeful process of making zombies?

The knowledge on the relations of the Nature and the human being and his place in the biosphere gives birth to the Collective Intellect and general understanding of the planetary situation. Spreading of the informational technologies and systems like the Internet, that of the symbiosis of the information science and television speeds up the ageing of general understanding, which is no more the destiny of wise people only. It is even the property of politicians. The forming of the Collective Intellect is the same natural process as the living substance evolution /1/.

The development of the informational technologies as any other technology is two-faced Janus. New technological facilities make the Collective Intellect forming easy, but at the same time they help to form the totalitarian system and besides necessary knowledge dissemination they can help to make zombies out of the majority of the planet population. This is taking place now. It is the reference to the anti-Utopia of Orwell.

Thus, the crotch in the process of public evolution appears at the modern stage of history. The Collective Mind can appear together with the Collective Will, and the horizons of the informational society will open in front of the mankind. The Collective Mind will play the same role as the mind of the human being in his body’s vital function: it will keep the society’s development from the results of the global crisis.

But absolutely different thing can happen: Only the countries of the “gold milliard” will possess the Collective Mind. The informational technologies will promote the totalitarianism strengthening. It will mean that 90% of the population of the globe will play the role of the Spartan’s helots and provide the satisfied and socially stable life of the “gold milliard” in the pollution free villages while the entire planet together with the countries of the “gold milliard” will continue its rush towards the abyss.

The modern stage of history is the final splash of the consumption society. Despite the further events it is the beginning of the agony of the system of values which appeared as a result of the property finding /1/. Will the society be able to stop the process?

### **The only property form is knowledge**

According to the academician N. N. Moiseyev there will be the moment when the public property that is the property which belongs to EVERYBODY will be the only form of the property. Knowledge, ideas, cultural values are the examples. The property's certain subject doesn't exist. For example, knowledge, in principle, belongs to all people, and any member of the society is a potential user of it. The property has one amazing feature: the more complete its usage is the more good it does to the society as the sizes of the public property (the volume of the knowledge) grow when it is used jointly. Bernard Show said: "If I take an apple from you, we will have the same apple. If I take an idea from you, we will have two ideas."

Thus the reconstruction of the structure of the property takes place inevitably. More than that, our idea about the property and its role in the life of the society changes gradually. But, unfortunately, those whom the fate of the land property or computer programmes copyrights depend on don't understand it properly.

We think that Internet electron libraries with the open access and books, paintings, films etc. with the evolution ideas are the reflection of this type of property. Now it is becoming a tendency (the national galleries of the world countries are free). It's high time to have open libraries and develop adjoining projects. We are forming the library like this at <http://roerich.com/>. A lot of evolution projects can be found here. Some most important of them are as follows:

- The journal Delfis: <http://delphis.roerich.com/>
- The journal A Human Being in the Social World: <http://journal.agni-age.net/>
- The Roerich News Channel: <http://news.roerich.com/>
- Analysis of Agni Yoga publications: <http://ay-books.roerich.com/>
- The forums on Real Ethics: <http://forum.roerich.com/>
- The Independent Internet Project The Epoch:  
<http://grani.roerich.com/>
- The ethic and philosophical journal The Epoch Distinctions:  
<http://grani.agni-age.net/>
- The Agni Project: <http://agni.roerich.com/>
- The Agni Yoga Symphony: <http://symphony.roerich.com/>
- The Beauty and Wisdom: <http://m-way.roerich.com/>
- About Unspeakable in Poetry and Painting:  
<http://kluchnikov.roerich.com/>
- Books-aid: <http://www.roerich.com/bookhelp/>
- Spiritual literature in different languages: <http://emrism.agni-age.net/>

- Association of the Researchers of the Psychical:  
<http://www.roerich.com/aipe/>
- Union of the Oriental and European Cultures Frisia:  
<http://frizia.agni-age.net/>
- Georgian Roerich Society: <http://georgia.agni-age.net/>
- Creative Association Raduga: <http://izrazsov.roerich.com/>
- The Planned conferences of the supporters of the Real Ethics:  
<http://conf.roerich.com/>

As each project has different preparation and experience but common aims there exist a real chance to integrate the projects both on the technical and organizational levels. It means the mutual help and, theoretically, creation of the virtual society of the new type which proposes access to it for everybody. This is the society to which all of us strive for. The most important thing here is not to lose the evolution direction vector and strive for high principles of the Ethic Code of the Roerich Movement.  
[http://www.roerich.com/codex\\_rd3.htm](http://www.roerich.com/codex_rd3.htm)

**The informational technologies as the antique Agora** This comparison was made by B. V. Markov from St. Petersburg /11/: “Mass media should be the place where moral and business, perception and poetry meet. It was the creation of such places that stimulated the development of the European culture. Dangerous and bright prospects of mass media should not hide the fact that they are the space where, like on antique agora, people exchange opinions. Our agora becomes not verbal but virtual.” The role of such discussions will grow further on but where they can lead is a question. Thus the stages of the noospheric mankind formation, its inevitability, if the mankind is going to live not only in the XXI century but further on should be reflected in the Internet and mass media. It is the essence of the Internet. We would like to cite John P. Barlow. He wrote in the Declaration of the Independence of the Cyberspace/12/: “Governments of the Industrial world, you are tired giants made from flesh and steel; my Motherland is Cyberspace, a new house of Perception. On behalf of the future I ask you, who don’t have future, leave us alone. Among us you are unnecessary. You don’t possess supreme power at the place where we have gathered... You have neither moral right to rule over us nor methods which could make us be frightened ...Our world is everywhere and, at the same time, nowhere. But it is not where our bodies live...We will create the Perception civilization in the Cyberspace. Let it be more humane and honest than the world created by your governments”.

As we understand now the mankind is to build the noosphere before coming into it. First of all it is to create the society able to implement the



ideas of noosphere genesis. The process of its construction will be difficult and long. It even can be painful. If the mankind succeeds it will be a new epoch in its history. N. N. Moiseyev calls it the noosphere epoch. Thus, the noosphere is the time, the period in the history of the mankind during which the human being's Mind is capable to define the conditions necessary to provide the co-evolution of the Nature and society when the people's Collective Will necessary to implement the conditions that is the noosphere development process is formed. These necessary conditions are called ecological imperative /1/.

**Goal achievement strategy** The authors support the approach put forward by E. Laslo in his book *Macroshift*. These are ideas of forming of the future on the basis of the modern principles of control. They are consonant with the ideas mentioned above. The idea of the approach is as follows: don't resist changes but use the power of the processes taking place in the preferable way.

Boleslav Trentovsky was the first to understand this. He is one of the founders of cybernetics as the science on the control of the processes of the science nature (together with Ampere who was the first to introduce this Greek term in the 30s of the XIX century which was later on forgotten and then revived by Norbert Winner in 100 years). This remarkable Polish philosopher, not recognized by contemporaries and forgotten by descendants, delivered lectures on cybernetics philosophy at the University of Freiburg in 1846. In them he stated his own understanding of the principles of control of the people's groups close to those offered today. N. N. Moiseyev called this conception "the principle of a helmsman": in his desire to reach the harbour the helmsman is to rely not only on himself; he is to use the power of Nature (the flow and wind force) to the maximum and not to direct his ship against the flow. The same situation is observed in the public life: the main thing is to understand the natural tendencies of the development. It is with the help of the knowledge and in the name of perseverance of himself on the planet the human being should overcome the difficulties of the development.

Trentovsky published the complete set of his ideas on the actions of the cybernet (he followed the tradition of usage of the Greek language in science terminology and called the human being who controls not only the technical system but the people's group by this word) in his paper *The Philosophy of the Cybernetics* issued in Polish in Posnan in 1848 /1/.

**Drawing near on the basis of the virtual reality.** The virtual reality is literature, mathematics, cinematography, music etc. (we even don't mention the Internet and television) /8/. Every type of the art brings the human being's fantasy to its field. It means that we can speak about the

world of Dostoyevsky, Tolstoy etc. It is interesting to note that Agni Yoga has the idea of “passing the tests under the sign” that is, having overcome the difficulty virtually and having done it properly there is no need for a person to pass the tests in reality. May be the secret of curing and beneficial influence of fiction ( *The Crime and Punishment* etc.) and other forms of the virtual reality is hidden in it? Thus, we can speak about the important role the reality plays in the life of a human being. We know about the leading role of the thought (everything we dream about becomes a reality sooner or later) from the Real Ethics. So, it is very important what we surround ourselves and relatives with, what thoughts we fill ourselves and the world around us with. “By changing ourselves we change the world.”

The computer creators spoke about different pitfalls at the earliest stage of the computer development (it is interesting to note that their papers are republished and are very topical, see /15/). N. Winner cites three parables (F. Goethe’s *The Magician*, *The Thousand and One Nights*, U. U. Jackobs’ *The Monkey’s Pad*) and drives to the conclusions: “There is only one way out – to build a society based on human values different from buying-selling... Those of us who promoted the development of the new science of cybernetics are, if to put it mildly, in unfavourable moral situation. This new science, the development of which we helped,

leads to technical achievements which create, as I have already told, huge possibilities for the good and evil. We can pass our knowledge to the world around us, and it is the world of Belsen and Hiroshima. We even don’t have a chance to slow new technical achievements down. The best thing we could do is to help the public to understand the general trend of the work ...and that the benefit from better understanding of the human being and society which this new science gives can postpone and outweigh our unintentional assistance to the power concentration (which always – due to conditions of its existence- is in the hands of people who are unscrupulous. But I’m writing this in 1947. I have to state that the hope for this is too small.” It is easy to note that the life proved the words of N. Winner. The informational war for the better operational system is waged on by many countries and communities. Thus, for example, to resist the USA operational systems in the person of Windows the EU and some countries of the CIS implement Linux. B Gates in his book *The Business at the Speed of the Thought* reveals his plans as to the informational control over the world.

Applying the ancient oriental principle to a longer line drawing (see /14/) the authors recommend to create such projects and to live in such a way that other people would follow them. The Internet gives a nice chance

for that. According to the proposal made by the Board of the Forum of the site <http://roerich.com> the closer integration of the projects takes place that makes it possible to avoid doubling and spread facilities more rationally. The idea of the new type Association which is drifting in the air and about which the administration of the journal Delfis spoke is in the same course. The Ethics Code of the Roerich Movement is supposed to be its basis /16/. We think it to be a new type of activity –collaboration in the name of the Common Good.

We would like to speak on some impact of using the Internet to put the evolution ideas forward. With us it's a report on the activities undertaken by us (there are some projects that obtained better results – we propose them and those who see the sense in this fair activity collaborating with us). The information is known to be searched with the help of search machines quite easily (though they can't cover all the information that Internet contains. It is still Terra Incognita). These machines “know” only the visible part of the iceberg. Nevertheless, as there is no other method found, we use the most all-purpose search system GOOGLE.COM By the way, if you address this search system 100 000 machines built into one cluster ( to process the huge quantity of the information with the reasonable speed) work for you. It gives the index to the popularity of the resources in the world. For example, the phrase “Roerich's Newsletter” will obtain 200 references (see fig.1) and the Oriflamma <http://roerich.com/> with all the projects mentioned above will be the reference number 1.

It is also interesting to find out which countries visit our project sites and how often they do it. You can do it from the central page of the site (the direct reference /17/). The number of the daily visits sometimes exceeds 1000 (like in January 2005). Russia, the USA, and Ukraine occupy the first three lines in the list of the visitors (more than 100 world countries follow them). The server SpyLog /18/ gives the more complete statistics of it and other catalogues and ratings we take part in. But the experts consider the search system Google.com to be more complete and independent. It is illustrated by the fig.1.

**Prognostications made on the basis of the mathematical modeling** A human being was always interested in his future. The people have tried to forecast the future for ages. Now, in the information epoch, the mathematical modeling plays the role of the prophet whom the majority of people trust. It has already saved the mankind. Thus the impact of the “nuclear winter” was forecasted by the computer modeling. It was enough to discover the fact that the nuclear war will cause the qualitative changes in the biosphere which exclude the possibility of the human being's staying on the Earth (the ideas as to the quantitative impact of the “nuclear winter”

were published in the book of N. Moiseyev, V. V. Alexandrov, and A. M. Tarko “The Human Being and Biosphere” in 1985. They played the determinant role in the decision to start the disarmament made by the governments of the super-states. Now we have all reasons to say that we are close to the ecological catastrophe. Thus the paper /3/ discusses 9 scenarios of the development of the mankind in the future. Only two of them are optimistic. As there is no hope for politicians, the forming of the Mankind’s Collective Mind and based on it Planetary Civil Society is extremely necessary to develop the collective will to quit wars, set the strategy of the co-evolution with everything alive on the planet in the name of the existence of the human being’s as a species.

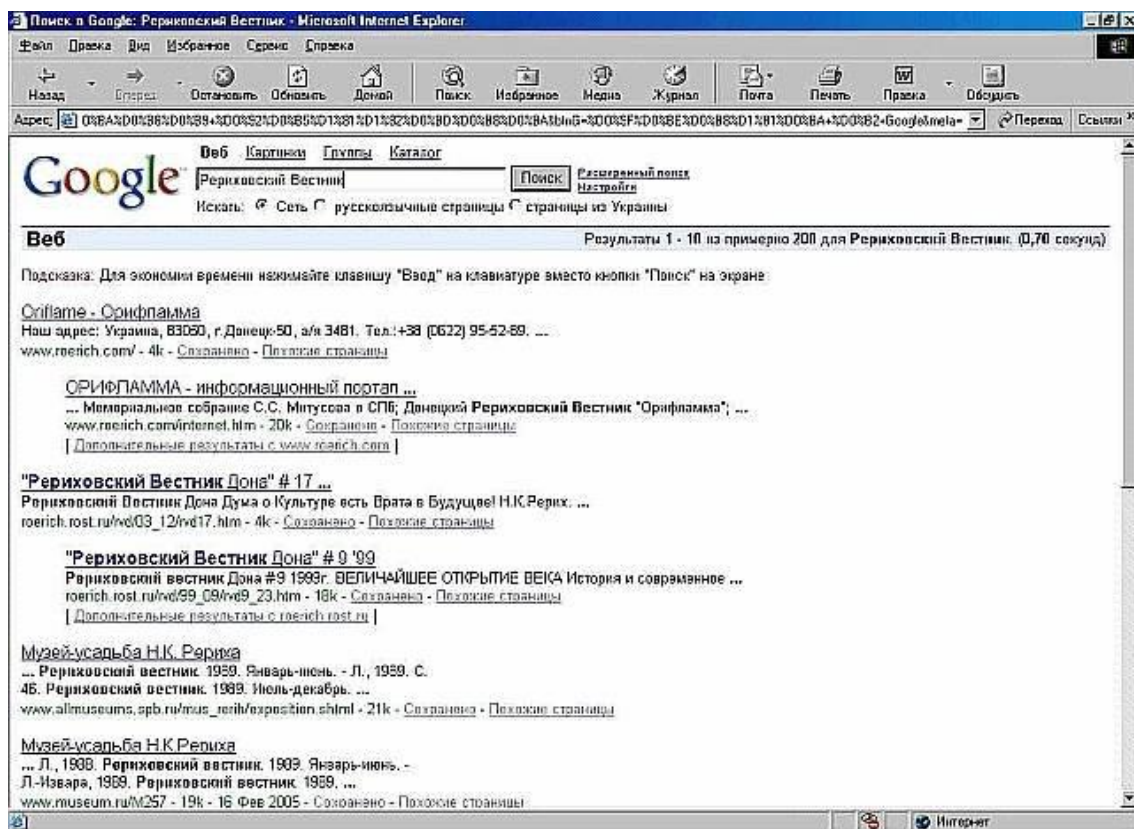

Fig. 1. The results of the search in the system of GOOGLE.COM

**Conclusions** So, we have a very efficient mechanism to implement the evolution ideas into life. Besides, there is a group of like-minded persons that includes many countries of the world, professionals devoted to the ideas of the evolution (let’s recall Plato’s words: “The ideas rule the world”) and there are all reasons to continue to develop the virtual community, put forward the ideas and form the future of the Planetary civil society at the qualitatively new evolution circuit – the noosphere stage. It is necessary to do it in the name of the future of the Earth planet. Our work in

this direction defines what we will pass to our children and grandchildren on. This is a matter of principle.

As we agree with the opinions of the scientists mentioned above we think that the establishment of the institutions of the noosphere's type (educational, pedagogical etc.) is necessary. These efforts are known to be made. May be they are called differently, but they are like that, as a matter of fact. For example, we are aware of the establishment of the Centre on training and bringing up of the generation of a new type. This Centre is based on the Institute of Oriental Studies. It is not a single establishment of this type. We, ourselves, are ready to do our best to develop the noosphere's libraries (we think that our electron library belongs to them) and all projects which already exist or which appear on both our domains and friendly ones having the same goals. We think that much depends on the "art to create interrelations" (see /19/).

There are a lot of initiatives to combine the efforts. We would like to mention that physical distances sometimes are difficult to overcome. Thus the latest initiative of the Internet portal RD "Vmeste" at the Far East is useful but illusive as hardly all interested will be able to come there. The Internet solves the problem of distance and we will be able to have virtual meetings (it, certainly, doesn't exclude physical meetings) to discuss the ideas now. We shouldn't wait for the meeting which may not occur in the real life. For this there exist the RD forums which now cover not only discussions but imply more integration which allows hoping for more mutual understanding and feed-up in the name of the Future.

To wrap up we would like to cite the N. K. Roerich's words: "Let the quality of the barest necessity be our closest stimulus. We are responsible for the future generation! The mankind is as responsible for the given planet as a gardener is responsible for his garden. We can't be fixed. We either move forward or step shamefully back. To move forward means creating with the help of everything (activity and idea), and using all the materials and taking all chances, bringing light to all narrow lanes of life. Each culture employee has only one enemy which is the dark homunculus of ignorance. The ignorance was considered to be the worst crime even in the ancient times. That is why the wish of every thinking person to live in the cultural country is quite natural. But for this every thinking person is constantly to bring the culture elements into both public and personal life. The wealth by itself doesn't mean culture. But the widening of thinking and its refinement as well as beauty feeling brings the finesse, spirit nobility which differ the cultural person from other people. It is this person who can build the bright future of his country. He understands his holy responsibility and is aware of the necessity of constant construction. Those

who will bring the beauty torch will comprehend the life of their relatives. The culture is, in its own way, the service for the Light. And the Light is one and invisible” /20/.

#### References:

1. N. N. Moiseyev. Universum. Information. Society. – M.: Ustoichyvy Mir, 2001. - <http://www.roerich.com/zip3/moiseev2.zip>
2. A. I. Klizovsky. The New Epoch World Outlook Basics. – Minsk: Lotats, 1996. - [http://www.roerich.com/zip/os\\_mirop.zip](http://www.roerich.com/zip/os_mirop.zip)
3. The Wisdom of the Earth Home. About the World Outlook of the XXI Century. Ecogeosphical Anthology, issue 4-5. Edited by B. A. Zubakov. St. Petersburg – Donetsk, 2003. - <http://www.roerich.com/zip2/almanah.zip>
4. S. R. Ableyev. The World’s Philosophy History. M.: Astrel, 2002.
5. V. B. Sapunov. Unknown Pages of the Biography of V. I. Vernadsky. // the proceedings of the Conference Science Schools. - [http://sir35.narod.ru/Sapunov/Vernadcki\\_03072.htm](http://sir35.narod.ru/Sapunov/Vernadcki_03072.htm)
6. Vernadsky. – M.: Publishing House of Shalva Amonashvili, 2001 (Anthology of the Humane Pedagogic). - [http://www.agni-age.net/zip/agp\\_vern.zip](http://www.agni-age.net/zip/agp_vern.zip)
7. Interaction of the Physical Fields with the Alive Substance/ E. I. Nefyodov, A. A. Protopopov, A. N. Sementsov, A. A. Yashin. Edited by A. A. Khadartsev. Tula: Publishing House of Tula University, 1995.
8. A. A. Yashin. Informational Virtual Reality. – Tula: Tulsy Poligrafist, 2003.
9. V. P. Kaznacheyev. General Pathology: Cognition and Physics: Preprint. – Novosibirsk. NIIRAMN, 2000.
10. C. Y. Klyuchnikov. Preface to the Book of Y. M. Klyuchnilov “The Poet and the Fairy. – M.: Belovodye, 2004.- [http://www.roerich.com/zip2/poet\\_fea.zip](http://www.roerich.com/zip2/poet_fea.zip)
11. B. V. Markov. The Human Being in the Epoch of the Mass Media) Symbols of the Internet Epoch) // Informational Society. – M.: ACT Publishing House, 2004.
12. John P. Barlow. Declaration of the Independence of the Cyberspace. // Informational Society. M.: ACT Publishing House, 2004. - <http://www.eff.org>
13. El Laslo. Macroshift. M.: Ustoychiviy Mir, 2001.

14. Ways to Wisdom: Acbar and Birbal/ Comp. S. V. Makhotina. – Minsk: Lotats, 2000. - <http://www.roerich.com/zip3/pathwisd.zip>
15. N. Winner. The Creator and the Future. M.: ATC Publishing House, 2003.
16. Ethics Code of the Roerich's Movement. - [http://www.roerich.com/codex\\_rd3.htm](http://www.roerich.com/codex_rd3.htm)
17. The Statistics of the Visits of the Informational Portal of the Donetsk Roerich's Newsletter Oriflamma. - - <http://roerich.com/stats/>
18. The Internet Measurements. - <http://spylog.com/>
19. R. Y. Rudzitis. The Art of Creating of the Mutual Relations. - - [http://www.roerich.com/zip/rihard\\_3.zip](http://www.roerich.com/zip/rihard_3.zip)
20. N. K. Roerich. The State of the Light. The Holy Patrol. – Riga: Vieda, 1992. - [http://www.roerich.com/zip/der\\_svet.zip](http://www.roerich.com/zip/der_svet.zip)

## **1.2. Search of meaning of life: aspects of synthesis of natural science and liberal arts**

S.G. Dzhura, Donetsk National Technical University

The life goal is to  
come to be in the Fiery  
World with all  
accumulations  
**Agni Yoga**

The problem of searching of the meaning of life is one of the most important in the world. The paper tries to discuss the meaning of life being a scientific problem: it offers an algorithm ( if it is possible to say so in terms of the case), defines the problem and shows both evolutionary and deadlock as in contrast to that versions of its solving.

It is, of course, not a new problem, and since the beginning of time each person has tried to solve it in a different way. We will try to analyze possible solutions and their appropriateness. All present approaches to the problem of the meaning of life can be split into oriental (philosophical) and western (technical) ones. We will also try to find complimentary ways to solve the problem which might be useful in working out of a general

concept of a human being's life, the state national idea etc. Both attitudes are just points of view describing the problem from different sides. The solving of each can help in understanding of the objective reality.

Some western statistical reports and sociological analysis shows that a person does not feel happy despite a safe way of life. Growth of suicides, crime, and drug addiction and other negative processes testifies it. Oriental thinkers diagnose the current situation as follows: " Large -scale goods that are produced in growing amount and are considered the necessary attribute of life in the West for the sake of having which people voluntarily sacrifice their lives, health and short staying on earth are according to both Milarepa and Buddha only an obstacle for the Correct Way of Life. According to Milarepa the life goal in a human being's body is not in getting stuck in the bog of ease and comfort that attaches to the world but in moving off it whatever fertile, flourishing and worldly happy it was due to discoveries of the western science" /1/.

The crisis of the goal set of the consumer society, which is cited as an example, is evident. But we have to reserve that the generally observed tendency, not some thinkers of the West that are not listened to in their native countries, is at issue. Shri Aurobindo says: "Two ideas widely spread in the West assist in strengthening of such a situation. According to the first one the lasting personal happiness is the main goal of life of any person. . The other one states that a person is born with a certain character that can not be ever changed".

The first one is childish and primitive, and distorts the truth of bliss of existence, which is the foundation of the nature. The life in the Universe could be impossible without this delight. But we should distinguish between the delight, which is an attribute of the Divine and independent on any condition, and pursuit of life pleasure that depends on many circumstances. The confidence in the right to personal happiness causes the desire to live for his good self , and enjoy life to the full at any cost. This life attitude is full of blind aggressive egoism, and is a source of different life conflicts and related to them distresses and causes disappointment, despair, and a frequent tragic ending in person's life"/2/. Viekananda, one of the brightest oriental philosophers, states that a person can owe everything being not tied to wealth. You can owe the material wealth only under such freedom.



Which original western technological solutions, which the West is so famous for, could be applied to the problem under discussion? Well developed technologies of applied sciences could be used in liberal arts and vice versa. We will try to illustrate it on the example of the philosophical assessment of the life goal and optimization problem in engineering.

According to applied sciences the life goal is similar to the optimization problem in which the goal is achieved in the optimal way (the best from some point of view). The optimization task is set as follows: it is the equation system that unites the goal function (GF) that reaches the extremum within the given limits (LIM). That is :

$$\begin{cases} \mathbf{F(x,y)} \Rightarrow \min/\max : (\mathbf{GF}); \\ \mathbf{x} \leq \mathbf{OFP} \leq \mathbf{X} : (\mathbf{LIM}) \end{cases} \quad (1)$$

Some very important for the set problem characteristics follow the optimization task solutions. These are contradictory criteria that are included into the goal function e.g. minimal cost at maximal efficiency (if the solution is within the limitation zone). The optimization task solution can give us the clue to understanding of a much more complicated task of the meaning of life. The goal function in this case can be rather complex (more than three parameters) and have no geometrical interpretation (though it can have a solution). Thus, according to the author, if the developments of applied sciences are used in liberal arts with the purpose of mutual improvement of understanding of the set problem, the right solution could be found. It might be an approach to the Beauty that must save the world according to F.M. Dostoyevski. N.K. Roerich made the idea more profound by emphasising that understanding of the Beauty will save the world. The beauty here is the goal, the criterion, the finger pointing to the Evolution Eternity...

There is every reason to set the problem of the meaning of life as an optimizational one. There is hardly anybody who is going to deny that the goal of life is to be reached in the optimal way. Thus, the goal of life can be considered the optimization task with its own GF and LIM. The choice of the goal function is the matter of principle. The bad goal definitely leads to the undesirable result. In this case the limitations could be as follows: a)

person's lifetime; b) moral, ethic and legal norms of the society; c) financial possibilities and other limitations.

Besides, there is to be a conditional classification of the life goal: that of an individual, a social group, a country, the mankind and much more important goals of the Galaxy, the higher and lower chains of the intellectual beings or the planetary chains that are reported by esoteric sources. It is logical to suppose that the life goal of the human being is to depend (be correlated) on the life goal of a team, a country, the mankind as a whole and other higher goals that can be defined by the human being by virtue of his consciousness. To confirm this we will cite the words from Sides of Agni Yoga : “ Our relation with the Farther Worlds occupies a special place in our life. We have an hierarcic link with them. The Earth is not a grain of sand in the ocean of limitless space, but its part linked to the whole that occupies its legal place belonging to it. The evolution of the earth mankind is related to that of the mankind in our world chain. The Great Plan is implemented inseparably. Space care is higher than earthly care. There are a lot of abodes in the kingdom of My Father and each one is to be cared by the Planet Spirits...”<sup>3/</sup>. To go on with solving of the set problems we need knowledge in liberal arts without which it is impossible to formulate the GF of the mankind. The esoteric literature formulates it very clear: it is the Common Good<sup>4/</sup>. Let us illustrate it by the fragment of one more competent work on understanding of Agni Yoga <sup>5/</sup>: “The Common Good is the goal of life or creativity or work common for all the team. Every element has its goal and responsibility in the general plan. That is why the responsibility of one can not be that of the other. You might remember a fairy tale about the animals that argued who was the most useful for their master. Each of them appeared to be the most useful in their own place. You can not think of your goal and purpose as the most important and necessary one and subordinate the urge of others to it. This urge will be limited. You should clearly understand that there is the Common Good that consists of many wellbeings, and every differentiation has its own way directed toward the Common Good but not to the wellbeing of your own plan”.

Thus, the understanding of this particular idea of the Common Good must be the goal of the person. While examining the evolution of the person himself we can see the change of the idea of the Common Good. The

private happiness in its narrow-minded understanding is motivated by the adverts, mass media and the way of life of the fictitious élite. To have the happiness many people commit a crime and break legal, social, ethic and other bounds (LIM from the point of view of optimization). The wisdom of centuries says that you can have your private happiness without that of other participants of the evolution process (other people and living beings) in the broad concept. Individual, group selfishness or that of the country can prevent in reaching the goals. Everything depends on the choice of the goal set. It is general knowledge that to reach the goal any state can use very powerful means. But the idea of the Common Good can hardly be found among these goals. As a rule these goals are as follows: search of economic, political and other advantages for a certain country. Unfortunately, in many cases it is not important what means it is done. A serious reader will find a lot of examples of it even in modern history. In this connection the words of P.F. Belikov are very important: “The world policy and evolution have never been and will never be the crucial moments of the evolution. The goal of evolution is not creation of the person who thinks in a correct political way, but the person who is able to think in space categories. Politics, economics and all social structures formed by them teach the person to know the matter on some small and timely examples only. It would be absurd to think that the fairness or injustice of these short-lived forms of person’s social life are “measures proper to the Space Mind” /6/. It was last century that it was calculated that all military means spent by all world countries daily could solve the famine problem on Earth. The one day military budget could solve power problem that is there would not be people who suffered from cold. Taking into account the calculations it is easy to understand how it is possible to help education, eliminate diseases, and solve other important social problems. Esoteric sources show that the lack of solution of global problems of the mankind is caused by people’s inert thinking, and the root of evil is in ignorance that causes all sufferings of this world.

The meaning of life is sure to be understood gradually. The popular wisdom says: “If only the youth knew, if only the old age could...” The genesis of understanding of the meaning of life is unique for everyone. According to Bhagavad Gita The God greets every suffering traveller any way he is going on...

Coming back to the optimisation task we should say that there is a very big, if not complete, analogy between the technical and philosophical tasks. More than that, there are some creative issues in both task types that do not allow speaking about the theory of either optimisation or philosophy. In the first case the thesis is illustrated by the fact that not any task has a single-valued solution as it can have a great number of them. The same can be said about philosophy. The task type is general for both tasks as it belongs to the so-called incorrectly set tasks, that is the tasks that have a limitless number of solutions. The well known fairy tale phrase “Go to don’t know where and fetch don’t know what” is a bright example of the above said. But even if we know what is to be looked for and where, the task solving is not easy at all. Only the person’s heart can hint about the solution in every particular case. The unearthly wisdom of fairy tales is presented in earthly images and every person understands as much as he is able to. Thus, the setting of the task of optimization and that of philosophy about the search of the meaning of life is creativity itself that can have great number of solutions. That is why we do not speak about the theory of optimization in its broad sense. We speak about the methods of optimization. A lot of the methods have been accumulated and the choice of them is to be explained.

To sum up the above we should mention that a person having a technical type of mind can formulate the life goal as an optimization task. He can do it with the help of progressive approximations- iterations. There is to be the verification ( correlation) of the obtained solution with the goal sets of higher organized communities ( a family, a country, the mankind, the highest hierarchical chains) after each of these iterations. Esoteric sources have a broad view on it /7/: “The Secret Doctrine” of E. Blavatskaya and the Doctrine of Agni Yoga recorded by E. Roerich under the guidance the space Teachers of the mankind show the great horizons for the coming transfiguration of the human being. “The life goal is the everlasting movement forward, the everlasting improvement, and the human being has all means for that. Everything is limitless and achievable in the unboundedness of the universe. Chances and achievements are limitless. Everything depends on the human being’s consciousness in which everything is achievable. As far as there is no limit for the consciousness growth, there is no limit either for the chances or for the

achievements. The highest consciousness centres that are in the human being's body are the means for accessibility. They strive for the Truth, the Light and the Knowledge and burn with fiery energy, and gradually transform into the organs of perception of the highest resources and the centres of power and might"./8/ "The human being's life meaning is in transfiguration of his nature and achievement of such an evolution stage when his own microcosm replaces all the earthly devices"./9/

Conclusions: 1) development of the optimization theory is possible on the basis of the synthesis of liberal arts and applied sciences; 2) the solving of the optimization tasks for liberal arts is based mainly on esoteric concepts; 3) the solving of a number of global problems for Earth planet is in the correct choice of the meaning of life ( that is in the correct set and later on solving of the optimization task); 4) studying of the given task is to cover the following stages: an individual-a group-a country-the mankind-the galaxy- the planet chain-the Eternity; 5) understanding of the meaning of life happens through the understanding of the meaning of the evolution of all the nature and definition of the place in this great Objective Reality Mystery.

We would like to finish the paper by the words of E. Roerich from "Space Evolution and its Goal" /10/: " The golden rule says: treat your neighbours as you want to be treated by them". However, the best expression of the moral law is in the words of Jesus Christ: " Love your neighbour as you love yourself". When we start loving other people as we love ourselves we really become moral. We do not think that by doing what the lowest animals do-eating, drinking and giving birth to children -we fulfilled the life goal and had the highest ending. We understand that the ending of the life meaning is in love to our neighbours equal to the love to ourselves. Only in this case we can liberate ourselves from the chains of self. This liberation can be achieved only the highest form of love of the true I in others. This true, free from the self love is possible when we understand our true nature. That is why it depends on understanding of our true nature. According to Hindu philosophy every individual soul is to become perfect and free from the self. Only then the soul reaches the spirituality plan".

### References:

1. Rechung. The Great Yogi of Tibet Milarepa.- Samara, 1994.-478 p.  
<http://www.agni-age.net/zip/milarepa.zip>
2. Shri Aurobindo. Mother. Bringing up of the Personality.- Aditi.: StP., 2000.
3. Agni Yoga Sides.- Notes of B.N. Abramov, 1969- Novosibirsk, Algim, 1993 (§ 297). [http://www.roerich.com/zip/grani\\_10.zip](http://www.roerich.com/zip/grani_10.zip)
4. Agni Yoga Doctrine. [http://www.roerich.com/7\\_18.htm](http://www.roerich.com/7_18.htm)
5. N. Uranov. Thoughts about Unboundedness.-M.: MCR, “Struna”, 2001.- 448 p.
6. P.F. Belikov. Spiritual Biography Practice.  
<http://www.roerich.com/zip/belikov.zip>
7. A.V. Svetlov. Shapes of the Future Science.  
<http://www.roerich.com/aife/russian/kontur.htm>
8. A.I. Klizovski. Fundamentals of the World Outlook of the New Epoch. [http://www.roerich.com/zip/os\\_mirop.zip](http://www.roerich.com/zip/os_mirop.zip)
9. Agni Yoga Sides.- Notes of B.N. Abramov, 1964- Novosibirsk, Algim, 1993 (§ 432). [http://www.roerich.com/zip/grani\\_5.zip](http://www.roerich.com/zip/grani_5.zip)
10. E.I. Roerich. Space Evolution and its Goal. New Epoch, № 1, 1999.

### 1.3. Internet-integration as a step to the noospherical thinking

S.G. Dzhura. Donetsk National Technical University

...the problem of understanding of the Highest World will become a topical one and science itself will see it as the evolution engine. We can not only dream about the approach, but we can also near the Highest World with the help of earthly measures. Each approaching of the Worlds is the victory over the flesh.

Agni Yoga, AUM, §12.124.

The author of the paper makes an attempt to understand the role of engineering in the mankind's evolution process on the example of spiritual communities. It studies the outlooks of collaboration on the way to the noospherical thinking in the light of the ideas of Agni Yoga.

The commanded word Evolution is the leading one in the understanding of the epoch. Everything which is dear to the spiritual person: the meaning of his life, family, country, planet, and the nature is concentrated in the concept. Many people are sure that the spiritual person is to replace the intellectual one as the intellect which is not enriched with cordial feelings is self-destructive. We will discuss the thesis from different points of view.

The society has passed the periods of industrial and post-industrial development and now entered the period of the information community. Awareness is thought to be the first precondition of self-discipline and controllability, which is of the main principle that sorts the chaos. What does the information mean? We will discuss it in its highest meaning as others are not of interest. The significance of the concept can be illustrated by the famous words of the Bible: "A Word was the first". What does the "Word" mean? It carries Information. Any word is the vibration that carries energy. According to Einstein any energy equals to  $E=mc^2$ .

The above can be illustrated by the following scheme.

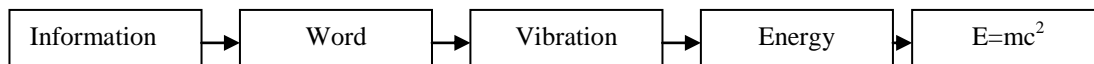

Thus, a non-material object (a word or information) is on the left, and its material form- mass multiplied by acceleration –is on the right. Of course, this is not a strong mathematical proof. The strong one uses the deduction method (from the general to the quotient) but not the induction one (from the quotient to the general) as it is in this case. According to research it is impossible to prove even fundamental theorems of a medieval mathematical treatise (only 39 out of 42 can be proved) on the deduction methods with the induction one being not used. Thus, to search the Truth we have to use the inductive proofs and other methods.

The current post-industrial development of the society is characterized by the information revolution in all spheres. Some Russian

scientists note that the mankind has changed the biological way of development into the noospheric one since the beginning of the 80s of the last century /1/. The curve of the mankind's growth becomes even which might lead to new global mechanisms of its self-organization. The Internet that appeared in the 80s of the XX century is one of these mechanisms. The forecast, that the amount of computers in the Internet will grow faster than people's population, is becoming true nowadays /2/. The quality of the information in the Net (the second name of the Internet) is one of the most topical ones. The author of the paper offers the criteria of the quality: the information is to correspond to the Evolution information vector /3/. And of course, there is a need in understanding of the concept of the Evolution vector, and we can not do without philosophical assessment.

We would like to discuss which concepts of Agni Yoga are fulfilled by hardware and its central phenomenon the world network Internet.

Let us examine the main evolution possibilities of the Net:

1. The possibility to transfer thoughts in the distance (as e-mail, ICQ etc.).
2. Stability of liaison patrol (web pages which are called the sites with positive information which is the evolution or spiritualized one). They can be likened to the candles lit at the altar and from which other candles (consciousness of other people) can be lit.
3. Free choice of the information (the implemented principle of free will is vivid here as nowhere else).
4. Attraction according to the consonance (the visits to the sites are done according to the inner consonance).
5. The Net is the spatial storage of the information (for example, the placement of the Doctrine in the Net is the implementation of the parable that says that the Doctrine is to be placed at the spatial and information crossroads which is the Net itself).
6. The spatial service. The evolution information "works" in the Net lighting up people's consciousness and follows Roerich's behest to "light up hearts". Unfortunately, there also is opposite process.
7. International collaboration is implemented in the Net as joint projects, forums, conferences etc.
8. Space purification. Sites as nodes are dischargers for spatial problems and have a serious evolution function.



This classification is not complete at all. But all said above is enough to understand the significance of the Net future. The Net grows quickly and becomes younger very fast.

The Net developers plan to control the world through it. It is an old dream of the egoists. The altruists have nice chances to follow another policy. There are self-organization nodes in the Net from the point of view of synergy. These are the sites with the evolution information which form a vector (called the attractor in synergy). This new vector differs greatly from the current one (if we speak about the Net as a whole). The task of all people that think about the future is to turn the vector in the evolution trend. Only then the Net and the mankind will fulfill its evolution purpose as the concept of both a human being and a computer is neutral. All depends on his (person's) bringing up and its (the computer) hardware. Either an icon or a cudgel can be made out of the human being. The spirit of the person can either be raised or dipped into darkness by the information filling of the Net.

How can this be done? The answer is in Agni Yoga that shows that you can cross out a line without touching it by drawing another line which is longer! That is we should avoid the sites with the destructive information and create new one that can inspire people to lofty actions. It should be a common case. There are preconditions for that in the Net itself. All the above is applied not only to the Net, but it is the Net that can make the results of work accessible to all.

We think that the placement of the Doctrine in the Internet which is the most powerful information crossroads of nowadays can be characterized by the following parable that can be found in the book "Signs of Agni Yoga" (4.669):

"Tell me, Lord, how we are to disseminate Your Doctrine? How can we find those who are fated to execute your words?"

The Lord answered: "Once a hermit was looking for someone to give the Revelation. He took a list and put it on the crossroads for the Sovereign to show who is to find his orders.

A girl came up and wrapped bread into the scroll. The hermit made another list and put it on the crossroads again.

A merchant passed by and wrote some calculations of his income on the scroll. The hermit went on putting the lists on the crossroads.

When the Lord asked him how he had spread the Doctrine, the hermit answered: “I am not the one to judge which of the birds would make the best nest out of the inscriptions”.

We do not know who will tear the list, who will forget about it, and who will put it at the head of the bed to confirm his ground.

“I do not think I was wrong to have given the list to those whom I do not know”.

The Lord confirmed the dissemination of the Doctrine to the unknown, without irritation, expectation and impatience.

Thus you should do the same; you should give without thinking whom to and everyday judgment.

Bird, carry the Doctrine and leave it near the hearth where someone lives and knows getting in foreseeing.

Leave the Doctrine at the crossroads”.

The parable characterizes the placement of the e-library in the Net. The library is accessible to everyone in the world around the clock. The computer in this case is a candle (with the Internet being the technical prototype of the noosphere) that helps to find useful information the lack of it in the Net is vivid. Thus, one computer lights others. The texts start having their own life, and the candles light souls of many people and the Earth itself. You should also help build the temple of the future in your hearts and share it with all who need it.

Nowadays the Net (as well as the mankind as a whole) can only potentially occupy a decent place in the Evolution. But now things are getting better. These are some sites the Internet can be proud of from the evolution context:

**Public organizations:**

- Siberian Roerich Society <http://www.sibro.ru/>
- Ural Roerich Society <http://www.roerichsibur.ru/>
- Estonian Roerich Society <http://www.roerich.ee/index.html>

**Informal creative organizations:**

- Association of Researchers of Psychic Energy Ассоциация <http://www.roerich.com/aipe/>

- Memorial Assembly of S.S. Mitusov in St. Petersburg  
<http://www.spbu.ru/Science/Centers/RoerichCenter/SCREENS/msssm.shtml>
- Donetsk Roerich Newsletter Oriflamma <http://www.roerich.com/>

#### **Research Centres:**

- Roerich Centre of St. Petersburg State University  
<http://www.spbu.ru/Science/Centers/RoerichCenter/>
- Roerich International Centre (Moscow) <http://dbserv.ihep.su/~roerich>
- Medical Academy of Spiritual Development in Dnepropetrovsk  
<http://www.madra.dp.ua/>

#### **Charities:**

- International Charity Foundation Roerich's Heritage  
<http://www.roerich-heritage.org/>
- Don Roerich's Foundation <http://roerich.rost.ru/>
- Belarus Roerich's Foundation  
<http://www.geocities.com/Athens/Atlantis/3777/>

#### **Museums:**

- New-York Roerich's Museum <http://www.roerich.org/>
  - International Roerich's Centre-Museum (Moscow)  
<http://roerich-museum.ru/>
- Roerich Memorial Estate Izvara  
<http://www.volosovo.boom.ru/rerix.htm>
- Roerich Electron Museum (Lipetsk)
- <http://www.lipetsk.ru/~roerich>
- The Roerich Museum-Institute in St. Petersburg  
<http://www.roerich-heritage.org/RUS/Museum.html>

#### **Newspapers, journals, publishing houses:**

- Journal Delphis <http://www.delphis.ru/>
- Journal Prometheus (alternative science and technologies)  
<http://prometheus.al.ru/>
- Journal The Planet of Gas-Discharge Visualization  
<http://www.gdvplanet.com/>
- Journal New Acropolis <http://www.newacropol.ru/>

- St. Petersburg Roerich's Collection  
[http://www.spbu.ru/Science/Centers/RoerichCenter/SCREENS/prs\\_0.shtml](http://www.spbu.ru/Science/Centers/RoerichCenter/SCREENS/prs_0.shtml)
- Publishing House of Ecclesiastical Writing Dokiud  
<http://www.dokiud.mksat.net/>
- Journal New Epoch (problems, search, research)  
<http://www.binet.lv/home/newepoch/russian/>
- Centre of Creative Research Belovodie (Moscow)
- <http://ethics.narod.ru/>

**Other not less interesting sites:**

- Wisdom Doctrines. Philosophy and Esoteric Traditions  
<http://www.wisdom.ru/>
- Oriental Studies  
<http://www.pvcentre.agava.ru/>
- Kitezh: Teosophy and Agni Yoga:  
<http://kitez.narod.ru/>
- Site about books of the Doctrine of Agni Yoga  
<http://www.etica.narod.ru/>
- The World of Agni Yoga (Nakhodka city)  
<http://www.agniyoga.ru/>
- Books as help <http://www.roerich.com/bookhelp/>
- Site on Agni Yoga and theosophy ( with the possibility to search texts)  
<http://www.agni.org.ru/>
- Agni Yoga  
<http://users.freenet.am/~agniyoga/>

The list, of course, is not complete. The more complete one can be found at <http://www.roerich.com/>

The positive aspects of computerization and the Internet are countless and can scarcely be overestimated. Engineering thought has a huge potential in the mankind's evolution development. The nature of the philosophy of engineering in its noospheric approximation consists of it.

According to a popular wisdom a person is to

- 1) plant a tree,
- 2) build a house,
- 3) bring up a son during his lifetime.

These three tasks can be combined into one virtual concept which is a site in the Internet. It is the tree, the house, and the son in the virtual understanding. If you are able to put into the virtual reality everything you wanted to put into your son, to build it up as the house for it to grow up and be useful to people as a nice fruit tree, it is wonderful!

You should also remember that you can access the tree from all the continents of the Earth planet. It can be proved by our site statistics. Every visitor of the tree can take all its fruit with himself. It is impossible with the traditional library, but for the virtual one it is all in a day's work. We come across the endless donation in this case as we speak about the information copying which is a common case for computers.

Now we are approaching the next basic concept of the Net – the virtual reality. It covers the visible and the invisible. The virtual means something which is unreal or not implemented into the reality. Many people use the concept the roots of which are deep in centuries. But it is a separate subject to be researched.

We are living in a wonderful time when thoughts become a reality very fast. You can observe it in your everyday life. Nowadays, when the Earth planet is in its development noospheric round, you can immediately inform people all over the world on your work and thus lay the foundation of the future. I think one of the goals of a conference is to jointly form the future and put a stone into the Bright City of the Coming Jerusalem.

According to the apt remark of P. Florenski "A human being becomes similar to what he contemplates". This can be applied to the Internet users. It does matter what a young (and not only) generation contemplates, which thoughts he fill the noosphere with and which taste he develops.

In the future the Net, which is around the world and works around the clock, and contains and transfers information, will be the noosphere in the best meaning of the word (the mind sphere according to V. Vernadski). This is to be the information with the capital P. Some Internet researchers mentioned that the Net had entered the noospheric period since the beginning of the 90s. Now it is important to interpret engineering developments of the mankind philosophically as without it it is quite possible to deviate from the development evolution way.

Technology widens the abilities of the person and helps him reach the level of the world thinking. According to the Doctrine the essence of the evolution is development of the inner abilities of the person without the technology. The Sides of Agni Yoga (v.8 §314) reads: "The telescope, the radio and TV is only the imperfect imitation of apparatus of living beings. Animals, fish, birds and insects have such a sensible and refined apparatus that people are not able to imitate yet. Now the development is in its way of mechanical and engineering progress, but the goal of Evolution is to arm the person without help of any apparatus as his microscheme contains the most amazing and perfect apparatus that we call the fiery one. It is possible to see and hear and transfer thoughts in a distance. But the distance is limited by nothing. We have laid down a definite plan of the development of the person. Once all the devices and machinery will be destroyed. But the spirit device is indestructible. Our goal is to direct the mankind's effort to reaching indestructible acquisitions. The task is extremely difficult because of denials and unbelief. Even minds of those who could lead us along the roads of the true knowledge are filled with ignorance. The way we outlined is clear and direct: it is the way of Evolution defined by the will of the Space Intellect. It had been defined before the human being appeared on the planet".

Thus, we entered the noospheric stage of the evolution at the beginning of the 90s of the XX century. Consequently, the mankind's thinking is to enter it too. A great number evolution tasks might be solved here.

The humanitarian correction through the Internet, which is the most important one, can be solved due to the change of the strategy of the Net itself. People's thoughts are given the second birth in the Net. It is the Net that can and is cultivate reason, kindness and eternal values as the manuscripts are not ruined here and you do not know where the word is echoed. We follow the behest of Roerich to light hearts by placing our papers in the Internet and creating web sites. It is a very significant fact as our young and educated generation pays much interest to this computer space.

How do thoughts influence people's future? Many ideas of science-fiction writers are known to have been realized as technical projects. The plane, the submarine, the flight to the Moon is bright examples of it.

Everybody knows such writers as Jules Gabriel Verne, I. Yefremov, S. Lem and R. Bradbury. The issue could be the subject of a very interesting research.

According to Lem's book "Technology Sum" we are at the landmark of the history of the tools that appeared in the sphere of physical labour, cross its borders, and intrude into the sphere of mental labour of the human being. We speak about the basic source of the giant process directed to the future and about the inevitable result of cumulative growth of science created during centuries. When he wrote the lines nobody could even dream about computers and the Internet.

It is the Net which plays the role of such knowledge accumulator (or is to do it). It is the noosphere, and as the sphere of intellect should be lit by the wisdom of the East, otherwise it will not be able to fulfill its evolution purpose.

In conclusion we would like to cite the Sides of Agni Yoga the ideas of which become a reality due to the technology (v.8 §241): "In the past people did not know what was going on in the neighbouring country and even the neighbouring city as news came very late. Now a distance is not an obstacle. People learn what happens at the other end of the world immediately. The technology has joined nations. The people are interested in the events taking place on the planet. We can imagine how much bright news will come when it is time for it. The world is being prepared to wipe the borders separating the people off.

Technical progress, discoveries in science and life itself go in one direction, despite the furious reaction of the darkness, to unite all the nations in collaboration, peace and solidarity. It is the Order of the Evolution".

#### References:

1. K.A. Zuyev. The Computer and the Society. M., 1990.
2. M.A. Basin, I. I. Shilovich. Synergy and the Internet (the way to the Synergonet). – St.P.: Science, 1999. - 71 p.
3. S.G. Dzhura. Evolution Nature of the Internet. / Proceedings of the Conference "Agni Yoga and the Future Science.- Yaroslavl, 2001. - p. 154 - 165.

## 1.4. Social aspects of the virtual reality

S.G. Dzhura, Donetsk National Technical University

Ideas rule the world.

Plato.

The paper discusses understanding of the virtual reality in the context of social activity of man.

The problem of spiritual impoverishment is very topical in the century of a leap of the post-industrial society in which the computer community is growing very fast and ethic self-consciousness is developing slowly. E. P. Blavatskaya wrote in her fundamental work “Secret Doctrine” (v.3, p.344): “Because of an extreme growth of people’s intellect and development of the fifth principle (manas) in man, the spiritual perception was paralyzed by the progress. The intellect lives at the expense of wisdom, and the mankind in its current state is totally unprepared to understand the awful drama of not observing laws of nature and the falling that follows it”. Understanding of philosophical features of the virtual reality in the context of social activity of the mankind might help find the ways out in the current situation.

We would like to give a brief description of the social aspects directly related to the concept of the virtual reality discovered by the computerization era.

To start with we would like to mention the fact that the virtual reality is not something completely new (as all the new is well forgotten old). Man’s thoughts and images he has receive their finalized form (the cinema, scientific texts and fiction, painting, sculptures etc.) during creative process. We are also aware of the potential scheme of man’s communication with the Universe (the God, Space Intellect, the Universe data base etc.): the man addresses the Divine through psychic energy and his nerve centres /1, 2/. Great wise men and prophets have always got orders, revelations and illuminations from Highest Forces. A common logic is unable to cover these mysteries. These are examples of communication with the Great Virtual Reality in its highest understanding. Now let us follow Socrates that kept silence when the God was spoken about. Further



on we will speak about terrestrial reflection of the virtual reality. Trying to understand this side of the virtual reality we will be able to find out something about its highest manifestation (according to the Bible as it is above, it is below). The dearest parts of ancient behests are known to have been passed orally, not in a written form. It is impossible to give correct interpretation of prophecies of Isaiah and Jeremiah, revelations of St. John the Divine, works of Plato, Origen and Confucius and other ancient thinkers without keys that were passed by word of mouth as the texts were completely coded. E.P. Blavatskaya wrote: “Those catholic missionaries that visited our country last century and thanked us for our hospitality by making a laughing-stock of our Scriptures are unwise and ignorant. It is true that Holy Canon of the Tibetan Kakhgiyur and Betanhgiyur covers 1707 separate works, 1083 (in 350 volumes) of which are for general use and 624 (in 77 volumes) are secret. However, could these missionaries be so kind as to tell us whether they were able to have at least a glance on the above secret folios? If the answer is “yes”, I assure the western pundits, that a native Tibetan will never understand the manuscripts and folios without the key to their original letters and their secret meaning. Every description of a place is image-bearing, and every word and name is masked in our system. First, you should study the decoding method and only then the equivalent secret terms and symbols for every word of the religious language. Hieratic Egyptian system is a child’s play compared with our priestly riddles”.

According to ancient initiations into Wisdom to achieve its high level a person was to read a book hidden in the walls of the temple column. Those who did not manage to do it were not consecrated. Thus, there is some Virtual Reality that can be assessed. Not everybody but only those with high moral base of the spirit and personality deserve it.

According to esoteric sources our epoch is interesting because of it is time to reveal the Secret Doctrines of the East (for example, the Secret Doctrine of E. P. Blavatskaya). The knowledge is accessible in the Internet which is the technical prototype of the intellect sphere (we call it the sphere as it covers the entire world, and we use the word intellect as it keeps the results of the mankind’s thinking). Further on the Internet is to be thought as the organized and structured knowledge area /6/ and as the original technical prototype of the noosphere of V.I. Vernadski /4, 5/.

Here is a brief classification of abilities of the technical virtual reality. **First:** every person has a chance to show the results of his work to many people all over the world, that is, it is self-expression by creation of a personal web page or an Internet project such as Russian Museum <http://www.museum.ru/>, Golden Philosophy <http://philosophy.allru.net/>, and also with the help of other socially important virtual forms such as the network channel of Roerich's news Roerich-NWC etc. **Second:** as the real distances are wiped off there is a chance to take part in different social movements, round work tables, discussions etc. (through the Internet forums and news groups); numerous virtual communities according to people's interest (psychology, medicine, religion, vegetarianism, philosophical poetry and many others) are set up. **Third:** the efficient information exchange takes place; different questions are discussed through the e-mail, chat, Internet pagers- ICQ, visual communication including visual conferences –Skype. **Fourth:** the problem of putting works on the shelf is solved. Everybody knows that any author wants to see social appreciation of his work and it is impossible for him to think that other people will never see it. The above list will be continued though we cannot declare it complete as the Internet system is in constant movement, it is developed and expanded. It gives broad possibilities for social activity of an individual including handicapped people, which is also very important.

The virtual signature-gathering campaign against some unpopular and harmful initiatives such as cutting down forests in the delta of the Amazon River or construction of a highway on the territory of national parks or holy places of Altai is a bright example of such an activity. To take part in it you need just to enter your name passport data and send your message. Thus, there is a real mechanism of social correction of many government programmes in different countries.

The growth of the computer community (mainly at the expense of Eastern Europe, Asia and Africa) is a common tendency nowadays. In 2002 the billionth computer was produced and practically nobody noticed it. The technological wave is coming. The hotheaded even say that those who will be able to find their place in the technological revolution or information society will be on the fairway of the evolution, those who will not – will be left out. The idea is quite disputable, but it is worth considering as

computer literacy now equals to the ability to read with all the consequences.

Let us look into the future of the virtual reality which is partially implemented today. We speak about the project Internet -2. It is the Internet itself with the speed which is three times as quick. How does it help? It sends texts and sound, and image dynamics. That is, there is a chance to communicate in a distance, to see each other, to have virtual meetings, forums and conferences without leaving your house. This second generation Internet is blooming though the public at large do not notice it. The external students of the Faculty of Computer Engineering of Hagen (Germany) take oral parts of their exams through video conferences. The group of doctors from Atlanta (the USA) gave a diagnosis of the broken knee for a patient that was 600 km away at the university hospital in Florida. Astronomers all over the world work with the telescope placed in the observatory on Hawaii. All this became possible due to the introducing of new high-speed Internet pathways of the second generation. In October 1999 a patient was operated on for the cholest, the operation being broadcast with the help of the Internet-2 net. At first there were 115 universities and clinics of the USA that initiated the development of the project ([www.internet2.edu](http://www.internet2.edu)). Germany had to spend 160 mln marks not to be left out the American net technology. In June 2000 the analog of the Internet 2 - G-Win ([www.dgn.de](http://www.dgn.de)) was launched. The Federal Minister of Germany E. Bulmann noted that they were going to reach international peaks of Internet technologies and thus to lay down the foundations for innovations, new companies and working places. Now the net unites 700 universities and other research institutions.

Now there is a chance to establish a virtual office of the company where e-mails and fax messages will be sent and received, the necessary papers will be taped and printed etc. The office can be rented.

The chance to get education is an important moment of the social activity of a person. We mean distance learning when an academic and a student communicate through the Internet. All the curricula and synopses are on the web site and accessible for everyone. The academics do not worry that the courses they deliver or parts of them can be borrowed as it is prestigious and all in the day's work in the West. The information on the copy right in the Internet can be found below. The laboratory works are

given in the e- form and can be passed virtually on the proposed software. To get the proposed tasks and send them done back is possible by e-mail. The students can ask their lecturers questions the same way. The lectures are given as video courses. The exams are taken either when academics arrive to the students or vice versa. That is the application of the virtual reality is vivid.

We have already talked about professional development which is very topical nowadays. The person living in the post-industrial society will be in demand only if he develops professionally. The virtual reality-the Internet- is of great help here. Everybody was in the situation when you could not borrow the necessary book from the library as someone else was using it.

The Internet has much which is so necessary for the user, and the information is constantly widened.

A university, as a place where people get the universal education, appeared where a library was in Europe. It is a historical fact. Now there are a lot of virtual libraries (lib.ru or roerich.com). Every respected publishing house or journal has its own web site (e.g. <http://www.agni-age.net/journal/>). So, there is a chance to get the so-called noospheric education: you can enrich yourself with the wisdom of the world (or at least its part). Every person gets according to his abilities and diligence and does not feel uncomfortable because he did not get his education at Oxford or Harvard.

There also are many unsolved questions as to the Internet. We speak about copyright. The recent trials showed that it is practically impossible to win the advantageous cases with respect to the virtual reality. We would like to remind you the case of the company that sold the software making automatic translations. The complainants were unable to prove that the copyright law covered the virtual reality. That is much information placed in the Internet is in conflict with the copyright at first sight. More detailed information can be found at <http://lib.ru/COPYRIGHT/>. But we would like to develop the idea. There are texts given on behalf of the God (the Bible, the Koran, the Upanishads, the Vedas, and Agni Yoga). The authorship is not disputed in the case. The more people will have the access to the texts, the better. The Internet is very successful in this respect. Many intellectual properties are placed with the note: “not for commercial use, only for

acquaintance with. If you wish to buy something go to ...” The user himself is to make a decision.

Creation of the virtual government and other proposals to solve the global problems important for the society is an interesting form of the social activity in the virtual area. Here we would like to mention the initiative proposed by the European Association ‘The World through the Culture’ on the creation of ethic councils that consist of the most influential people of a country (<http://www.peace-through-culture.org/>). The council works in Lithuania. Its functioning equals to that of the historical councils of the elders. The author of the concept V. Augustat thinks the councils like that are to be independent, be above politics and have the right to put a veto upon the laws adopted in the country. The expert committee that controls the social correspondence of the laws presented to the Bundestag is the prototype of the council in Austria. It has a right to ban the laws. The mankind does not have the future without the spiritual and moral transformations. Someone might have other recipes of the ways out of the crisis. In this case Mr. Augustat kindly asks to inform him as soon as possible (E-mail: [spirale.verlag@t-online.de](mailto:spirale.verlag@t-online.de)).

The fact that there is no perfect software on which the virtual reality is based is the axiom. Launching of an American satellite to Venus that failed because of one mistake in the programme is a bright example. Nowadays there are no technologies to make programmes in which absence of mistakes is guaranteed (we certainly speak about profound programmes, not simple ones). That is why because of the gaps in the software and connection of computers into the net there is the possibility to have a total control over the user (that is unauthorized collection of the information under plausible pretexts such as advertizing). The matter is that while the user visits different sites, temporary files are recorded to the computer, the so called cookies being among them. The cookie is a small fragment of the data on the history of visiting the given WWW –server by the user which is automatically created by the server on the user’s computer. This allows tracking the sites the user visited, the information he is interested in. Later on he sees the advertisements related to his interest in his e-mailbox, though he has never ordered it. The user’s computer can also send some confidential information such as passwords. The files can be accompanied

by spy programmes, computer viruses etc. sent to his computer. We will explain below how to avoid it.

Thus, the user appears on the negative site despite his wishes due to some technological tricks. When he tries to close the site, some more of them with the similar contents are downloaded. After the switching off the computer (the radical method) or its restarting and entering the browser the user comes to the latest downloaded site with the negative contents automatically.

Only physical disconnection of the computer from the Internet gives the experienced user a chance to restore the initial set up of the program. So, the situation when the darkness does not let the one who touched it go is obvious. Besides, the information is recorded on the computer (including the computer viruses and confidential information collection). It takes place even if you have the note of the maximum safety level and use the so-called free software. To avoid it you should know some rules of the virtual cleanliness and follow them: have the connected daily renewable anti-virus monitor and scanner (we use KAV: [www.avp.ru](http://www.avp.ru)), anti-spy module Anty-keylogger (<http://www.anti-keyloggers.com/>) and check the computer by the anti-spy scanner Ad-aware (<http://www.lavasoft.nu/>) from time to time. If the above programmes find errors, you should look for the reasons and eliminate them. It is very important to have professional development in this area as the ignorant usage of the virtual reality can cause deplorable results (permanent loss of the information, virus infection, automatic transfer of confidential information etc.).

Many companies are working at hypnotizing the user. More than that, the prototype of the consciousness programmer appeared in the market ([www.bwgen.com](http://www.bwgen.com)). The sounds that are generated by the program are able (depending on the spectral composition) plunge the user into different states- from meditation and sleepiness to heightened workability and concentration. The programme operation principle is based on generation of beatings (difference frequencies) among the sounds perceived by the right and left ear. The developers declare that they are not responsible for any aftereffects of the application of the product and strictly recommend not using it if you suffer from heart and nervous system diseases. The same can be said about neurolinguistic programming (NLP) described in the Net.

Thus it is vivid that nowadays the virtual reality is mainly used not for the mankind's evolution but for the mankind's degradation. It can be seen according to orientation of the information offered by the virtual reality (90% of which is negative). I would like to give some examples to show how the evil is organized, attracts user's attention (that is tempts) and how warlike it is. Everybody is familiar with the process of sending Internet messages to a great number of addressees that contain the information not asked for (it is the so-called spam). Pornographic, extremist and other mailings (related to slave trade, sadomasochism, and different misconducts our educated age meets) that discredit human dignity is disseminated this way. Besides, if the user has the Internet-pager, the first message he gets is scabrous. The sites like that (we will call them the sites with negative information) prevail in the Internet and bring out the freedom of morals and manners if one may call it so. According to the doctrine of Agni Yoga "the freedom that attracts man so much is an illusion. There is the choice freedom in unboundedness, and the beauty itself is in it. The freedom approves the man who appoints the consequence world for himself. The dependence life is built like that. The existence is endless and they are bound with construction phenomena (Unboundedness 1)" /7/.

The man is given the head and the heart to differentiate and not to be caught by different tricks of the virtual reality. Besides, he might come across either fact in his everyday life. Of course, it is much easier to fight the devil together, especially if you know what to turn to. The Internet might be of help. Torsion fields not accepted by the modern science might recognize the "good/evil «of the information in a technical way. The right-hand field is proper to the good thought, the left-hand one – to the evil. Ethics can be introduced into the machine rotation in such a way. It is a theoretical precondition so far /8/.

Certainly, we can not ignore the entertainment industry in the Internet. First of all, these are games the majority of the users play. The author thinks it is the leaving of the social activity of the individual, its transferring into the virtual level which is the prototype of some trap. According to the latest computer game world competition the sportsmen, if one may call them so, are to play on the computer for 10-12 hours a day to

keep their shape. When will the sportsman work for the benefit of his family, state, and the mankind after all?

The author mentioned the splendour and misery of the virtual reality briefly, and he thinks the virtual reality potential is to switch over to the positive field sooner or later (sooner is preferable). It is our cause! More than that, it is a very interesting sphere which is the catalyst of man's self-discovery as he compares his own abilities with the virtual ones automatically. Besides, the man, according to the esoteric knowledge, will own all the advantages of the virtual reality in the future. The communication process is of mutual enrichment and the Internet might be of invaluable help. The sites that are really valuable do not call in their web pages, people discover them as treasures. We would like to cite a piece of R. Tagore's verse "Do not be Strict in your Opinion":

Let happiness pour into your chest  
 And overflow!  
 You will find the treasure on your way,  
 So, hand it round to the people on the way!

It is the virtual reality where you can share the treasure as nowhere else. Should you have any comments as to the paper and the author's virtual projects placed at [www.roerich.com](http://www.roerich.com), do not hesitate to contact the author by the E-mail: [dzhura@rambler.ru](mailto:dzhura@rambler.ru). The author will be happy to study them.

#### References:

1. V.V. Puck. Engineer, Mathematics and Others: Simple Methods of Mathematical Modeling of Natural and Anthropogenic Processes/Donetsk State Technical University. - Donetsk, 1995.-224 p.
2. S. G. Dzhura. Issues of Donbass Ecology and Computer Technologies in Student Training// Electrical Engineering and Power Engineering. Proceedings of the Faculty of Electrical Engineering. Donetsk State Technical University. – Donetsk, 1996, p. 158-159.
3. E. P. Blavatskaya. The Secret Doctrine. V. 3.-p.



4. S.G. Dzhura. Noosphere through the Internet // Proceedings of the International Scientific Conference Creative Heritage of V.I. Vernadski and Modern Times. – Donetsk: Donbass, 2001. – p. 156-159.
5. S.G. Dzhura. Evolution Nature of the Internet.// Proceedings of the Scientific and Practical Conference “Agni Yoga and the Science of the Future”. – Yaroslavl, 2001. – p. 154-165.
6. Intellectual System Knowledge Bases/ T. A. Shavrilova, V. F. Khoroshevski. – St.Pb: Peter, 2000. – 384 p.
7. The Doctrine of Agni Yoga. Unboundedness 1. - [http://www.roerich.com/7\\_18.htm](http://www.roerich.com/7_18.htm)
8. G. I. Shipov. Physical Vacuum Theory. Theory, Experiments and Technologies. – M.: Science, 1997.

## **1.5. From noosphere to ethikosphere**

A. Y. Anoprienko, S.G. Dzhura, A. A. Yakhno

Creation of noosphere out of biosphere is  
More profound and powerful  
Phenomenon than man’s history is.

**V. I. Vernadski**

The paper concerns the features of transferring of noosphere to ethikosphere, as much depends on understanding of the mankind’s development ways. Thus, some see the noosphere as technosphere that is to meet momentary and short-sighted goals. More than that, due to the Internet development it is turning into the sphere of intellect, but not Mind, and is not lit up with anything which is higher, and is more and more resembling necrosphere, pornosphere, and extreme sphere of permissiveness. A creative researcher as a citizen of the Earth (if he thinks of himself as that) can not be satisfied with it. The paper gives the background and analysis as the current practice of straightening the way of

cognition of the mankind's future as the way from the noosphere to the ethikosphere or the noosphere as the ethikosphere.

The research results have been proved by the author at a number of international conferences /1-4/. The conferences concluded that the way out of the crisis, in which the modern civilization was, was in synthesizing of the western and oriental world outlooks. That is why the subject matter of the current conference aimed at preserving of the heritage of the Roerichs that are an example of such synthesis, is so topical. The paper is based on profound findings of western and oriental thinkers, looks for the true marks of the future and its voluminous or golographic picture. The author of the paper /5/ demonstrates the approach to the Universe which is a hologram.

### **Chronic delay in reasoning of a situation and its one-sided analysis**

The fact that the philosophical reasoning of the processes taking place in the society is in 15-20 years (according to some researchers) delay with the development of the civilization is extremely important. The probability of misrepresented choice of the development vector as a whole is extremely high under the situation. Besides, the analysis is carried out on the level of institutes of strategic research in some countries aimed at getting profit and priorities for the particular country, while the analysis of the situation the mankind is in as a phenomenon is excluded. The true efforts are made only by separate public organizations and scientists /3, 8, 12/.

That is why we fully agree with the idea of S. Lem which can be found in the collection of his philosophical papers "Molokh": "The mankind is absolutely unprepared to take and master new technologies (especially biotechnologies and nanotechnologies) and huge computing capacities of the computers as there is political separation and cultural opposition" /6/. The solution of the problems can be found by making interdisciplinary research. The famous German philosopher Hans Lenk speaks about the necessity to turn to the oriental philosophy: "We deal with forming of a new world outlook paradigm demanding to treat the nature as a complex mechanism in which we live and must interact not breaking its main functional links, but not as lifeless and rough "material". This paradigm turns us to oriental cultures, in which the world has been always seen as an organism with the developed ethics of non-violence." /7/

The academician N. Moiseev speaks about the unsteadiness and danger of the situation the modern civilization is in: “First we should have an idea of the social and political organization of the world community within the transitional decades that might either find the ways of transition of the society to the noosphere epoch or accelerate the marching to the abyss. There is no third way! Then, of course, we should think of the structure of the society of the noosphere epoch which will come if the mankind is able to overcome all the difficulties on the way of the epoch formation”/8/.

**From «homo sapiens» to «homo noospheres» passing the dead-end of «homo desapiens faber»**

In XX century V. I. Vernadski said that the practical activity of the man was becoming the main geology forming power of the planet. Today, in the century of nuclear energy, the man is able to destroy everything which is alive on the planet. That is why understanding of the potential of the activity of people and dangers for them the activity can cause if it is not controlled by the Joint Intellect is one of the keystones of the world outlook and the education system /8/. To the authors’ mind the Internet is to be the prototype of the joint intellect if the evolution servers (educational, cultural etc.) are accentuated.

At the same time, it is practically impossible and dangerous to separate the role each of the sources gets, study them separately and ignore their influence on the man as they make up the essence of the spiritual world of the man and determine his behaviour under difficult situations.

According to V.I. Vernadski the more destroying power the mankind has, the more perfect the mechanisms making social control over the power must be. It is impossible to improve the control without a philosophical platform appearing in the frameworks of the noosphere theory. Creation of the theory is the top priority task of the XXI century /9/.

Vernadski realized how grand the mankind’s geological activity was and how unpredictable its aftereffects could be. He said [15]: “ We observe how the influence of the man’s consciousness and joint intellect on geochemical processes is growing”; “the amount of carbonic acid is growing while the civilization is developing”; “thus the civilized man breaks the fixed earth balance.” Vernadski was very emotianl: “The man is acting not as *Homo sapiens*, but as *Homo sapiens faber*”. He exclaimed:”Where is this

new geological process going to stop? Will it ever stop?” The famous thinker departed about a half a century ago. The period showed that the man’s activity had approached unreasonable scales. We can state that the man is acting as *Homo desapiens faber* /10/ nowadays.

From the point of view of synergy it is not surprising that a new greater ecological catastrophe is going to finalize the modern development of the biosphere due to the super active *Homo desapiens faber*, and the we will see the self-destruction of the current Earth life form /10/.

The scheme of the modern and possible future development of the biosphere that reflects modern synergetic views is as follows: the loading on the biosphere caused, according to Vernadski, by the activity of *Homo sapiens faber* grows greatly under the transition from the pre-industrial to the industrial period. In the post-industrial period the loading becomes extreme, and the man, figuratively speaking, becomes the *Homo desapiens faber* /11/. According to some experts /17/ the biosphere has entered the bifurcation period ( or will enter it very soon) /12/.

The authors of the paper /10/ sum up that the main noospheric task of the world scientific community is to define the scientific and system development of the synergetic scripts of the development of the biosphere for the nearest 50-100 years.

The primacy of wealth is the deadlock of the technical civilization. The noosphere ideals mean the primacy of intellectual values, freedom of a personality from economic oppression and unfair social organization.

The man is to have limited material and limitless spiritual demands. The thoughts of Vernadski are very topical today: “You can not put off your care about great and eternal till the time when everybody has a chance to meet his elementary demands. Otherwise, it will be too late. We will give in the wealth to the people whose ideal will be the phrase “Give us bread and circuses!” They will prefer eating, drinking, taking pleasure of love rather than doing anything else. Can a teacher be satisfied by bringing up the Skalozub, Molchanovs, greedy bankers, depraved playboys, gluttons and egoists?” /13/

The term «homo noospheres» was introduced by the group of authors in /14/. The academician A. A. Yashin says /8/: “The modern Russian scientist and philosopher V. P. Kaznacheev, the recognized continuer of the doctrine of V.I. Vernadski on noosphere thinks /15/ the vectorization of

the movement of total intellect of the Earth planet is the most important issue as it is the intellect implemented in culture, spiritual aspirations, scientific and technical progress, etc.”

The mankind total intellect movement vector is to be analyzed at the moment of transition of the «Homo sapiens» to the «homo noospheres» /16/. The authors of the paper think that the virtual reality (the mass media, science, the Internet) is such a total expression and reflection of the joint intellect. It is a separate subject matter. This very element is very important as ‘the future of the planetary community will greatly depend on the knowledge nature and dissemination, education, culture, and accepted world outlook universal phenomena that N.N. Moiseev calls the world outlook. “This is the element of the world outlook that can have purposeful influence. The future of the society depends on its ability to understand and accept inevitable taboos and strictly follow them rather than on perfect machines and technologies.” /8/

The work /17/ is an interesting book in which the history of philosophy is generalized. The author overcomes the traditional Europocentrism of philosophy, reports the oriental and Russian thoughts and historical and cultural phenomenon of esoteric philosophy. That is why we think the following idea of E.P. Blavatskaya is very important /18/: “The remark might seem inaccurate and groundless, but we think that science loses but not wins when it ignores ancient and even medieval esoteric literature or its remains. The people that study it will transform many coincidences into the natural results of the previous reasons that can be demonstrated.”

### **Knowledge is the only property form**

According to the academician N. Moiseev the moment when the public property is the only property form is coming. Knowledge, ideas, and cultural valuables are an example of it. There is no property subject, as knowledge belongs to all people and any society member may use it potentially. The property has the amazing characteristic: the more complete its usage is, the more useful it is for the society as the amount of the common property grows under the joint usage of it. The words of Bernard Shaw illustrate it brightly: “If you have an apple and I have an apple and we exchange these apples then you and I will still each have one apple. But if you have an idea and I have an idea and we exchange these ideas, then each of us will have two ideas.”

Thus, the property structure is inevitably reconstructed and, which is even more important, our idea of the property and its role in the life of the society is changing gradually. Unfortunately, those whom the land property and computer software property depend on do not understand it properly. E-libraries in the Internet with the open access and having evolution ideas (books, pictures, films etc.) are the reflection of the property form. And it is the world tendency (the national galleries of the world are free). Now it is high time the open libraries and related projects to be set up.

Creation, development and maintenance of the projects devoted to the implementation of the Roerichs' ideas is the general tendency of studying and actualization of the Roerichs' heritage.

The library project Oriflamma (<http://roerich.com/>) is aimed at implementing the goal. Its credo is "The Internet is the Technical Prototype of the Noosphere". It has the materials of the above conferences on V.I. Vernadski's heritage, the unique materials of the book of collected papers "The Wisdom of the Earth Home (St. Petersburg- Donetsk) /12/. The book of collected papers is devoted to the year of Russia in Ukraine, the year of V. I. Vernadski and 300<sup>th</sup> anniversary of St. Petersburg. More than 1200 unique books and journals and more than 20 international projects are in open access.

The project is the result of the work carried out by 10 enthusiasts from different countries and continents. It started with the meetings with different scientists of nowadays at Donetsk National Technical University. V.V. Puck was one of the founders of the first seminars. It was his presentations that gave a birth to the idea of the project of the noosphere libraries. This year the Department of Mathematics named after this bright person has hosted the conference devoted to the 70<sup>th</sup> anniversary of V.V. Puck. His papers can be found in the above mentioned e-library.

The visitors from more than 100 countries pay a virtual visit to the library. Russia, the USA and Ukraine occupy the first three lines of the list. The project has already been rewarded by both Ukrainian and international awards: the first prize in the Ukrainian contest of non-commercial project of 1999 organized by the Kiev journal "Internet-marketing", and now it is among the nominees of the nomination "The National Heritage" in the Russian contest "Golden Site".

Here you can also find some other evolution projects:

- The international non-governmental association “Ethics and the Future Science”: <http://ethics.roerich.com/>
- The journal “Delphis” <http://delphis.roerich.com/>
- the journal “Man in the Social World”: <http://journal.agni-age.net/>
- The channel of the Roerich’s news: <http://news.roerich.com/>
- Analysis of the publications of Agni Yoga: <http://ay-books.roerich.com/>
- Forums on Agni Yoga: <http://forum.roerich.com/>
- The independent Internet project “Sides of the Epoch”:  
<http://grani.roerich.com/>
- The Ethic and philosophical journal “Sides of the Epoch”:  
<http://grani.agni-age.net/>
- Agni project: <http://agni.roerich.com/>
- Agni-Yoga symphony: <http://symphony.roerich.com/>
- Beauty and Wisdom: <http://m-way.roerich.com/>
- About unspeakable in poetry and painting:  
<http://kluchnikov.roerich.com/>
- Books-assistance: <http://www.roerich.com/bookhelp/>
- A spiritual literature in different languages: <http://emrism.agni-age.net/>
- The Association of the Psychic Energy Researchers:  
<http://www.roerich.com/aipe/>
- The Union of the Oriental and European Culture “Frizia”  
<http://frizia.agni-age.net/>
- The Georgian Roerich Society: <http://georgia.agni-age.net/>
- The creative association Raduga: <http://izrazsov.roerich.com/>
- Planned conferences of the Agni Yoga’s supporters:  
<http://conf.roerich.com/>

All the projects have been prepared in a different way and the practice is different, but they have a common goal. There is a nice chance to integrate them on both technical and organizational levels. Thus there will be mutual assistance and establishment of the new virtual society which is accessible to everyone. The main task is not to lose the evolution vector and follow the lofty principles of the Ethic Code of the Roerich’s Movement [http://www.roerich.com/codex\\_rd3.htm](http://www.roerich.com/codex_rd3.htm)

Besides, there are 10 names of CD/DVDs:

- The most complete library on the synthesis of science, religion and philosophy;
- Favourite music of the Roerichs;
- All issues of the journals “Delphis” and “Man in the Social World: problems, Research and Outlooks”, “Oriflamma”;
- Proceedings of the inter-disciplinary conferences “Ethics and the Future Science” and many others.

More detailed information can be found at:  
<http://roerich.com/banner.htm>

### **Information technologies and the ancient Agora**

B.V. Markov from St.Petersburg wrote /19/: “Mass media must be the place where moral, business, knowledge and poetry meet. The places like that have always been the stimuli for the development of the European culture. Dangerous and optimistic outlooks of the mass-media must not conceal the prosaic fact that they are the space where people exchange their opinions as they used to do on the ancient mountain. Our agora is not verbal, it is a virtual one”. Further on the role of the discussions is going to grow, but who knows where they can lead to. Thus, the steps of formation of the noosphere mankind and its inevitability (if the mankind is going to live not only in the XXI century, but longer) should be reflected in the Internet, and the mass-media.

John Barlow wrote in his Declaration of the Independence of the Cyberspace /20/: “The governments of the industrial world, you are the tired giants made of flesh and steel; my motherland, which is the cyberspace, is a new house of consciousness. You are history. I ask you on behalf of the future: leave us alone. You are not wanted here. You can’t be at power where we have gathered. You have neither moral right to rule over us, nor methods to make us be frightened... Our world is everywhere and nowhere. But it is not where our bodies live. We will create the civilization of consciousness in the cyberspace. Let it be more human and fair than the world which your governments have created before.”

As we understand now to enter the noosphere the mankind is to construct it and establish the society organization which will be able to implement the noospheregenesis ideas. The construction process will be difficult and long, and it might even be painful. But it will be a new epoch in the history of the mankind. N.N. Moiseev calls it the noosphere epoch.



Thus, the noosphere epoch is the period in the history of the mankind during which the human mind is able to define the conditions necessary to ensure the co-evolution of the Nature and the society when the joint will of people necessary for their implementation is being formed, that is when the noospherogenesis is developing. These necessary conditions are called the ecological imperative /8/. The Doctrine of Agni Yoga says: “The balance and the equivalent are destroyed by the mechanical understanding of the world. Half a century ago we cared about growth of the physical knowledge (the middle of the XX century). We achieved much in the area, but the spiritual consciousness lags behind the physical one. Ethics lost its way among the piles of formulae. Machines distracted man from the art of thinking. There are too many robots now! To have the world balance we need a heart that will save us. The evil wish violates the earth aura.” /21/

### **Conclusions**

1) It is necessary to reduce the lagging of the understanding of the development of the technosphere from that which has existed for 15-20 years practically to zero, and to take into account the research results of the so-called “Happiness Institute” from Japan. They calculated the risks or efficiency/inefficiency of the discoveries made in Japan. The forecast must include not only one country, but all countries in the world.

2) To define the legal prerogative of the ethic approach and self-restriction of the mankind in all spheres as the ecological imperative.

3) To support the Memorandum on holding of the Noosphere Global Forum on adoption of the Noosphere Constitution in 2006 adopted in 2005 in Japan.

4) To support any initiative on development of culture, science and education, to expand the activity of the association “Ethics and the Future Science” and to find the ways of financing of the initiatives. There should be a corresponding fund for this.

### **References:**

1. Creative Heritage of V.I. Vernadski and the Modern Times/ Proceedings of the conference- Donetsk: DonNTU, 2005; <http://www.roerich.com/zip3/vern2005.zip>

2. Creative Heritage of V.I. Vernadski and the Modern Times/ Proceedings of the conference- Donetsk: DonNTU, 2003; <http://www.roerich.com/zip3/vern2003.zip>
3. Creative Heritage of V.I. Vernadski and the Modern Times/ Proceedings of the conference- Donetsk: DonNTU, 1995; <http://www.roerich.com/zip3/vern1995.djvu>
4. “Ethics and the Future Science” –interdisciplinary scientific conferences (2001-2005). - M.: Delfis, 2001-2005. <http://www.roerich.com/delfis/confer.htm>
5. M. Talbot. Holographic Universe. – M.: Sofia, 2004; <http://www.roerich.com/zip3/talbot.zip>
6. S. Lem.Molkh. – M.: ACT: Transit-Book, 2005, 718 p.
7. Hans Lenk. Thoughts about the Modern Engineering. – M.: Aspect Press, 1996; <http://www.roerich.com/zip2/lenk.zip>
8. N.N. Moiseev. Universum. Information. The Society. – M.: Ustoichivi Mir, 2001; <http://www.roerich.com/zip3/moiseev2.zip>
9. V.B. Sapunov. Unknown pages of the biography of V.I. Vernadski.// Proceedings of the conference Scientific Schools. [http://sir35.narod.ru/Sapunov/Vernadcki\\_03072.htm](http://sir35.narod.ru/Sapunov/Vernadcki_03072.htm)
10. V.A. Goltsov, L. F. Goltsova. Hydrogen Civilization of the Future – a New Concept of the International Association of Hydrogen Energy// Creative heritage of V.I. Vernadski and the Modern Times. Proceedings of the conference. – Donetsk: DonNTU, 2005; - <http://www.roerich.com/zip3/vern2005.zip>
11. Goltsov V.A., Veziroglu T.N.//Intern. J. Hydrogen Energy.–2001.– Vol. 26.–P. 909–915.
12. The Wisdom of the Earth Home. About the World Outlook of the XXI Century. Echogeosopic Literary Miscellany, issue 4-5. Edited by V.A. Zubkov. St.-Pb.-Donetsk, 2003.-272 p.
13. V.I. Vernadski. - M.: Publishing House of Shalva Amonashvili, 2001. (Anthology of Human Pedagogic).- [http://www.agni-age.net/zip/agp\\_vern.zip](http://www.agni-age.net/zip/agp_vern.zip)
14. Interaction of Physical Fields with Living Material /E. I. Nefyodov, A. A. Protopopov, A. N. Sementsov, A. A. Yashin; Edited by A.A. Hkadartsev. – Tula, Tula University Publishing House, 1995.

15. V.P. Kaznacheev. General Pathology: Consciousness and Physics: Preprint. - Novosibirsk, NIIRAMN, 2000.
16. A.A. Yashin. Information Virtual Reality. – Tula” Tulski Polygraphist, 2003.
17. S. R. Ableev. History of the World Philosophy: textbook. - M.: ACT, 2002.
18. E. P. Blavatskaya. The Revealed Izida. V.1. Nauka. - M.: EKSMO, 2003. [http://www.roerich.com/zip2/isida\\_1.zip](http://www.roerich.com/zip2/isida_1.zip)
19. B.V. Markov Man in the Epoch of the Mass Media (Symbols of the Internet Epoch) // Information Society. – M.: ACT Publishing House, 2004.
20. John Barlow. Declaration of the Independence of the Cyberspace // Information Society. – M.: ACT Publishing House, 2004.- <http://www.eff.org>
21. The Doctrine of Agni Yoga. - M.: MLQP, 1993-1997 , The Fiery World, part II (262). <http://www.roerich.com/zip/mo-two.zip>

## **1.6. On the way to homo noosphericus**

A. V. Levshov, S.G. Dzhura, V.I. Chursionov

*Problems of modern science are analyzed. The exit directions from the world outlook crisis which is the basis for the economic one are offered. Synthesis application from historical positions is proved and prospects of its application for the solution of basic tasks are shown.*

**Introduction** The modern crucial state of the society is obvious. N.K. Roerich said: “...we are living during the days of mortal struggle between the mechanical civilization and the forthcoming culture of the spirit” /1/. V.I. Vernadski agrees with him in his diaries: “The situation is dangerous, but it is also far from being hopeless. I do not doubt that we will approach our goal despite the perturbations. I somehow feel the inner power of Russia, and, whatever happens, I think of new research; our fears about the possibility of the civilization collapse are groundless... I am very

optimistic as to the formation of the noosphere. It is not fatalism, it is an empirical conclusion...” /2/.

According to the materials of the international philosophical conferences held by the Department of Philosophy of DonNTU philosophical understanding of the realities of the civilization development is too slow. This causes the crisis of the society. We will try to examine the aspects of noospherical transformation of science and education as well as noohumanism and the vector of the social and anthropological evolution. These are landmarks of the way to the mankind of a new stage of the noospherical development – to the homo noosphericus.

**The problem analysis** The author made the analysis in the paper /3/: “According to the modern state of education, which is reflected in pedagogic, its analysis is to be started with the main problem- the goal of pedagogic, the ideals of which are not in demand today”/3/. The modern pedagogic has only a utility function: it serves the society which gives a social order to it. That is the pedagogic is secondary although its main function is to look for the truth and lead the civil society to the truth. That is the riders exchange their places and the lower is trying to rule the higher now. The situation can go on for a long time. This is the world outlook problem which is the source for the world outlook crisis. The society is going the wrong way. “The world policy and economics have never been and will never be the crucial moments of the evolution. The evolution goal is to form the person able to think by the Space categories, not the person who thinks correctly from the point of view of politics. The politics, economics and all social formation created by them teach the person to know the matter on minor examples. It would be ridiculous to think that justice or injustice of these short-lived forms of the social life of man is a distinctive feature of the Space Intellect “/4/. The more complete is the action of the country towards the evolution, the closer it is to the evolution development of the man (the evolution pedagogic partially comes from it). The countries that do not correspond to their evolution meaning leave the Earth: “The Space Evolution is taking its normal course. The efforts of the dark forces to stop it are useless. The Earth is a special case of no significance in the Unboundedness. Every earthling joining the Evolution enters the world life flow. The one who goes against the Evolution dooms himself to regress and the final destruction in the long run. The evolution

dregs are destructed and go through the painful stage of decay. It is impossible to be against the evolution for a long time. It is better to join it. The fate of some people, nations and races that do not correspond to the evolution is rather sad: they are swept away from the life arena. The decay and degeneration can take ages. There are some races and great nations that became nobody. Both the Australians and the Bushmen are the remains of the previously great races. They had better join the evolution. It is not limited by the Earth only. The way to the stars is wide and endless. The travelers that go the endless way often do not know their destination. The man's destiny is great, but it is to be realized, otherwise the most important thing can be lost" /5/.

L.M. Gindilis /6/, who watched the stages of science formation and emphasized the valuables peculiar to the research in the period of experimental natural science formation, spoke about the problem of losing the main scientific purpose which is universalism, collectivism, unselfishness, and organized skepticism. At the second half of the XX century science became an appendage to high scientific technologies, and the valuables of the scientific search faded. Unfortunately, profit, business, a social order, but not the truth understanding came to the foreground

**Science state change** The modern science changes its states, which is a normal phenomenon described in Coon's theory of scientific revolutions /7/. The discovery of the "God's part" or Higgs boson, which is the cornerstone of the standard model that fully (compared to all physical theories) describes the Universe construction, is the scientific sensation of this year /8/. However, the majority of researchers think the standard model is only a stage on the way to other more complicated theory that can explain such phenomena as a dark matter and dark energy. There are reasons for that. According to the modern astrophysical data, that can be obtained indirectly (see "The Earth and the Universe" №5, 2006), the mankind knows only some percent of the Universe matter in which Mendeleev's periodic table is included. All the rest is the dark matter and substance that make up 95% of the Universe.

It appeared that the so-called visible matter consisting of usual substance observed by physical devices makes up approximately 1% of all physical Universe matter. The famous periodic table is included in it. Three more % is the usual matter consisting of atoms or known elementary

particles which are not registered by any devices. This invisible matter (or hidden mass) can be found only due to its gravitation influence on the visible, registered matter. Thus, total amount of the usual substance, or baryon matter, makes up only 4 % of the Universe. The rest 96% is covered by the so-called dark substance (24-25%), and the dark energy or cosmological vacuum (71-72%). The nature of the invisible matter is not clear yet. The dark substance is thought to consist of very massive and poorly interacting particles. The particles have not been discovered yet, so the issue of the substance nature is open. The Higgs boson was discovered in the summer of 2012. Dr. Tara Shears from the University of Liverpool says: “We will examine how often it breaks into Z-bosons and W-bosons. It can be included into the standard model, but if there are some deviations, it means that some new physics works. It will be the first time when we are able to spot through the window, and see what is there behind our current understanding” /8/.

She says that Higgs boson is the final missing element of the modern theory of elementary particles of the standard model that unites all types of interactions except for the gravitation one – the strong interaction (connecting quarks in protons and neutrons), the poor interaction (the interaction among electrons and a neutrino) and the electromagnetic one /8/. If it is so, it will be the evolution in physics. For example, the theory of existence of additional spatial dimensions can be proved. It is the most significant experimental discovery during last 30-40 years /9/.

The author of the paper made his presentation on multidimensional model of consciousness (it is very important in pedagogic for its true composition, forecast and the process control) at the international conference in Moscow /10/. The model was accepted and did not cause serious objections.

As far as the majority of the matter in the Universe is the invisible components – the dark substance (it is rather a relative term as there is no adequate one) and the dark matter, the question on the unknown matter that can not be seen by an eye and observed by any physical device is quite appropriate. The author of the “Physics of the Impossible” and “The Physics of the Future” M. Kaku who interviewed 300 Nobel Prize winners to write his book says: “As far as the dark energy is concerned, it is still one of the greatest not finished chapters of the modern science” /11/. Isn't

it the invisible matter the ancient cosmologists revived by theosophy, Agni Yoga and the Temple of the People spoke about? Isn't it the matter that forms the invisible world (or at least its part) and the recognition of which is still the stumbling block in the modern science? Physics has approached the invisible world, and has stopped in front of it hesitating whether to make the final step or not /2/. From the point of view of the traditional science this step was made (Higgs boson) and the second one- recognition of metascientific knowledge (and metapedagogic that follows it) – is to be made. It is not an easy thing. The researcher of the process L.M.Gindilis writes /13/: “Climbing the stony slope of science, a researcher can reach the crest of the mountain range to the sphere of metascientific knowledge. He can turn right on the way to the peak along the narrow range and appear at the science slope again. But he can also turn left and fall down the abyss of pseudoscience. So he has to walk on the razor's edge between Scylla of orthodox science and Charybdis of the pseudoscience”.

**New methodology** Any new material is to be understood or realized. According to classical physics the characteristics of the measured object observed under the measurements exist prior the measurement, and the measurement itself only eliminates our unawareness of the subject-matter. The situation is different in quantum physics: the characteristics discovered under the measurement might not exist prior the measurement... The reality is formed and not only realized” /14/. Kaku says /12/: “The idea of space consciousness that runs through the Universe is metascientific. It is important that physics suits the idea”. One of the authors says that the bridge between the metascience and classical science has been built /10/. Now we are to discover the new types of the matter that correspond to each of the 11 dimensions and find formulae (mathematical dependences among them and the classical substance that is the small part known to the modern science). When the science about the living being tries to check itself by “exact” sciences a lot of mishaps appear.

Oleg Ananyin, the Director of the Center of Historical and Economic Research of the Institute of Economics of the Science Academy of Russia, gives a very interesting fact in his presentation “Economic Modeling: between the Object and the Customer”: when American satellites were launched to Mars the method of evaluation of the possibility of life existence on the planet was used. The result was negative as it had been

expected. The researchers used the method to evaluate the possibility of life existence on the Earth planet. And according to it there is no life on the Earth planet. No comments, as we say in such a case. Now we know how to treat the results of the official science that requires restrained and controllable development. We have to do it as at war time (the information war has never stopped) the rival knowledge is always used (when a prisoner is interrogated some information is received and used). That is new thoughts are to be accepted at least as a hypothesis even in such a situation as the traditional science has always been saturated by them: e.g. science fiction novels). The main inventions of nowadays have also took it into account.

### **The criteria of super-scientific knowledge**

Requirements to the source of the super-scientific knowledge are given in /13/:

1. Its authenticity is to be doubtless.
2. As it is an original document that refers to a certain epoch, this is to be reflected in the language of the source: the terms used in it must correspond to the scientific language of the epoch it belongs to. For example, it is ridiculous to expect the use of differential equations in their modern form in the source that refers to the epoch of ancient Egypt.
3. The next issue is how far the source can pass ahead its epoch. If it looks into the remote future it might pass the consciousness of the contemporaries. For this not to happen, the document draftsmen should keep to the knowledge that is accessible to the people living in the epoch.
4. To use the criteria of the super-scientific knowledge we should know the source epoch and the state of science very well. We should know what is accessible to it and what is behind the knowledge limits /13/.

The idea of ancient Indian science on the least linear measure is an example of the source that is outside the limits of the period. Other examples (Stonehenge) are given in the papers /15/ and /16/. The detailed analysis of the sources of metaknowledge (theosophy, Agni Yoga, and the Temple of the People) made by L.M. Gindilis (an astrophysicist, a full member of the Russian Space Academy, a researcher of Moscow State



University) is an important addition to it. He collected more than 50 papers of one author on one subject-matter. He examined the concept of the sun in ancient and modern sources. It fully corresponds to the above criteria as well as the idea of the Earth getting 1/3 energy from the sun and 2/3 of it from meteorites. His calculations prove this hypothesis that might seem strange at first glance. Thus the criteria can be used in the field of the super-scientific knowledge or metapedagogic. It was with the help of it that the mankind got knowledge in all known and unknown centuries. The fact was mentioned in energy and informational pedagogic /17/ and in evolution pedagogic.

The author of the paper /18/ that has a very interesting title (the consciousness materiality) says: “The energy of consciousness makes state, political and economic figures to conclude on social significance of the raise of the level of consciousness and culture of all workers. The culture and consciousness level growth is the most powerful energy stimulant for millions of people. Now, when the information is of the global nature, when it is the direct productive power, only the person that owns it can resist its energy”. According to another author /19/: “A book helped us focus our attention and push more profound and creative thinking forward. The Internet, on the contrary, encourages us to use quick not connected pieces of information taken from different sources. It is the ethic of an industrial epoch, the ethic of speed and efficiency, optimized production and consumption. Now the Net is reforming us in its image and likeness. We become adepts of fast and superficial scanning and lose the ability to concentrate, think and reflect”. That is why the paper style is like that. The author wanted to have time to tell us something really important. According to the paper /20/ the mankind has been falling down to the abyss for a long time and has already passed the turn when it could slow down and follow the road bend. But it even has no time to slow down...

### **To homo noosfericus**

The noosphere will be formed. Different people are involved into the process in different ways. There are many people on the planet who are deliberately involved into the construction of a new planetary state. V. I. Verndaski is one of the brightest and most significant representatives in the rank.

His optimism is amazing. He is a person of the XX century and speaks about the modern historical process in its true colours. He might have derived his optimistic world-view from a very deep and light source.

In his book “Philosophical Thoughts of a Naturalist” /21/ he wrote: “...the device of the mind is closely connected to a word and does not cover all the knowledge about the reality, the scientific creative thought is beyond logics. Intuition and inspiration is the basis of the greatest scientific discoveries... We enter the area of the phenomena which is not covered by science yet, but we should not only take it into consideration, but also make our attention to it stronger.

Hindu philosophy covers it in a more profound way. Both new and ancient Hindu thought has philosophical trends that do not contradict our modern science (it has less contradictions compared with many philosophical systems of the West). These are some systems related to Advaita Vedanta and religious and philosophical searching of the modern religious seeker Aurobindo Ghosh (1872-1950). Shri Aurobindo Ghosh and V.I. Vernadski lived up to the end of the 40s of the XX century. It was a special biosphere and historical turning point. Both of them joined their consciousness with that of all people and the planet. Although our brilliant compatriot was a traditional materialist he, like the Hindu thinker, was searching for the Spirit Truth all his life.

Space radiation sends powerful flow of forces to the Earth planet that gives new characteristics to the boundary parts of the planet. They “model the Earth image”. The part of the earth’s crust covered by the transformers that convert the space radiation into the active earth energy is called the biosphere. This cover of the planet is not only the substance field, it’s the energy field. Its substance is active and full of energy due to the space radiation.../22/

It is interesting to know that the Doctrine of Agni Yoga also says about man as “a living-being transformer”. The thoughts of V.I. Vernadski and Great Teachers coincide in the idea that the man causes earthquakes by his behavior and world outlook.

Man is an inevitable manifestation of a huge natural process which logically lasts for at least two billion years. The anthropogenic era has been created by geological history. The geological process shows people as the community in relation to other living beings on the planet. Organisms used

to influence the history of the atoms necessary for their growth, nutrition, breathing and reproduction. The man made the process wider and spread his influence on all chemical elements. He changes geochemical history of all metals, forms new compounds, reproduces them in the amount equal to that of the natural reaction products. He changes the run of geochemical cycles... The man changes the environment deliberately! He creates “new” animals and plants, the new nature. He deliberately got rid of starvation that creates the precondition for the endless reproduction. This unity and power over the surrounding used to manifest itself spontaneously. The unity idea has been the state task and mass mover for 2.5 thousand years. The mankind is involved into the historical process that covers the entire planet. The ideas entered everyday life unconsciously and were influenced by the creatively inspired personality that organizes the masses. Poetry-religion-philosophy- science is the personality’s social expression. The spiritual unity of religion appeared a utopia. The state thought is helpless in this respect. Philosophy that created powerful human being’s mind, logic, mathematics, psychology is helpless in the effort to create the spiritual unity that can connect the mankind. The scientific thought that can unite the mankind appeared in a real and clear form during last centuries. The scientific knowledge has been growing continuously since the VII century /22/.

Science is a result of work of not only scientists. It is spontaneous reflection of man’s life in the noosphere. The science is the manifestation of a whole set of man’s thought in the society. The science is not a logic construction or device looking for the truth. It is impossible to understand the scientific truth by logics. It is possible to do it only with the help of life. An activity is a characteristic of the scientific thought.

We work as the nature does. I penetrate so deep in my research, as none of philosophers and religious mystics thinking by words do. It can be compared with a musician’s work. Working with scientific facts and entering the nature a scientist experiences the world reality as none of people can do in other forms of their consciousness /22/.

In the XX century a single scientific thought covered the entire planet. It is the main precondition of transition of the biosphere into the noosphere. Science influences our lives and becomes a planetary factor. It can not be stopped. The scientists can not move away from making the

noosphere organized. We are living in a very interesting epoch. Very significant events are taking place in the field of man's thought. The idea and feeling of the entire whole, the casual link of all observed phenomena have never been as profound, bright and clear as they are in the XX century. The science and mankind's power over the environment are growing fast despite wars and destructions. The scientific movement remains strong as all the losses are recovered by discoveries very quickly. The science is growing in the current rotation of human misfortunes and finds the means to stop barbarism inside itself. This experience cannot stop the transition of the biosphere into the noosphere. We are entering the crucial period of the process strengthening and the research is the manifestation of man's geological activity. The noosphere formation is beyond people's will and can not be stopped by human history. It is the effect of inevitable occupation of the entire planet /22/.

The noosphere is the "new nature" with new processes; the geochemical function of the biosphere is changed – "new" atoms are included into the cycles and fill the planet surface; the exchange of substance, energy and information with the space becomes faster. The scientific thought which is a new "product" of the biosphere creating the noosphere and closely related to the man and the society is included into the exchange process. Telepathy is one of the manifestations of the thought is not an illusion: life phenomena related to parapsychic ones are a part of the material environment that covers the real space of the naturalist.

#### **Necessary correction of the scientific paradigm**

The change of scientific paradigm because of reappraisal of the role of consciousness in the physical world is a fundamental historic event in a new millennium. Bio-and-energy-informatics proclaims new ideas that transform the modern natural science. It plays the leading role in the development of the universal knowledge and reveals deep links between the consciousness and physical processes /23/.

Paranormal phenomena are real and it is useless to deny it. It is impossible to study them from the point of view of the science classical paradigm. These are the main points of the new paradigm /24/:

– inexhaustibility of the matter forms, the existence of subtle matter plans of being; the usual matter makes up about 4% of all the mass of the Universe, and the "hidden mass" makes up 29% /25/;

- physical vacuum is an inexhaustible source of energy; “dark” energy makes up 67% in terms of mass /25/;
- a single information field of the Earth planet and the space (on a subtle matter carrier);
- life is an integral part of the matter like mass, energy, information; everything is alive; field forms of life are possible;
- man is much more than just a molecular complex of cells.

The main essence of the man is in his biofield, which is a complex of different subtle matter bodies and the carrier of his consciousness and which remains stable after the death of the physical body;

- consciousness is an integral part of the being like substance, energy and life;
- man is by no means the peak of the evolution on the Earth.

Those who finished the human stage of the evolution and became more than just a man go on living on the planet. They are the founders of the world religions, Mahatma or Teachers of the mankind. The criteria of reliability of the results of the research carried out in this non-traditional sphere are the key problem of bio-energy-informatics. They are crucial in defining the boundaries between knowledge and pseudo knowledge. As the science development practice shows the boundary is not stable. A number of stated scientific “truths” are refuted by the latest research data and become false. But there are cases when much of the pseudo knowledge and artifacts are proved to be real and “assimilated” by official science /23/.

The non-traditional science is not completely included into the so-called traditional one. In the new text-book /26/ there is a chapter called “Nonofficial Science” in which it is not defamed as it used to be, but the authors say that the knowledge is an addition to the traditional science and the consensus is to be found. The knowledge should be included into the science general paradigm as it does not contradict the traditions of the latter and is a part of the spiritual culture.

**Science as a part of the spiritual culture** The wealth created by the man has always defined the material culture. The spiritual culture was formed as a type of man’s understanding of the being (the world). Science is a part of the spiritual culture. The value of the science is in its ability to discover the truth through knowledge /26/. The science became dominant in its understanding of the being. It is the highest cultural value and causes

the belief in its endless abilities. The idea of mathematical belief (as it is an axiom) appears. Thus, we have a category of belief (a religious term) inside the science. K. Popper, an Australian and English philosopher, expert in logic, sociologist and science historian wrote: “We should get used to treat the science not as a “**knowledge aggregate**” but as a **hypothesis system**, as that of guess and anticipation that can not be grounded in principle but which we use until it can stand inspection and the probability and reliability of which can not be completely ensured” /26/.

We agree with the conclusion that if there is the research object there is to be an empiric test based on the principle of verification and falsifiability to prove the hypothesis truth /26/. However, the verification principle is out of question in the nano-range achieved by the current science where even the experimenter’s thought influence the test result. That is one and the same test carried out by different experimenters can give different results and they will not be a mistake as the verification principle is applied only if the idea and the opinion are turned into the direct test. The principle of verification of falsifiability of scientific propositions is built not on hypothesis acknowledgement but on its denial, on banishment of lie and arguments that seem true. The conclusion is as follows: the science is transformed from the “hypothesis cemetery” (Poincaré) into the true science only when all methodological tests are carried out and thus any knowledge **has a right to exist** /26/. We think that this can be also said about empiric knowledge. The information received from a prisoner of war for interrogation is taken into account though everybody understands that the enemy might not tell the truth. The information is accepted as a hypothesis and tested as it might be true.

**The crucial role of culture** Many people think that the civilization is the main winning of the mankind, but we support the idea of E.I. Roerich that can be found in her letter of September 5<sup>th</sup> 1935: “The civilization has forced out the idea of Culture and many people do not understand that it is possible to be a civilized barbarian. We do not take into account the fact that the culture later developments are accumulated during centuries while the civilization can be formed within a decade” /27/. This point of view fully coincides with the conclusions of classical philosophers who can not be classified as esoterism followers.

We mean a famous Spanish philosopher and culture expert Jose Ortega y Gasset who did his classical research on university education as a specific cultural and social practice and wrote a book more than 70 years ago. The ideas of the book are still significant, and more than that, they are more topical /28/.

“The current situation is obvious to give a birth to violence the results of which are now being paid by Europe. The reason of the catastrophe in Europe is that an English doctor, a French doctor and a German doctor are vulgar; they have no vital system of the world outlook corresponding to the time. This average person is a new barbarian lagging behind the epoch, archaic and primitive compared with the terrible present and its problems. The new barbarian is a professional who knows much more than he did before. He is an engineer, a doctor, a lawyer, a researcher, but he is much more vulgar too”. A half-educated person is known to be much worse than an absolute boor as he thinks he knows what he does. F.M. Dostoyevski said: “The semi-science was the most awful evil of the mankind. It was worse than famine, war and pestilence known up to the current century. The semi-science is a tyrant that has his slaves and priests; the tyrant whom all people worship with love and inconceivable superstition; whom the science itself trembles at and indulges shamefully.”/29. / The words of Socrates: “There is only one good which is knowledge and only one evil which is ignorance” are very important for pedagogic. Stephen Hawkin, who works at the same department as Newton did, thinks that “the main enemy of knowledge is not ignorance but the illusion of the knowledge presence”.

Ortega goes on: “Let us not be the science barbarians. The science is the great achievement of the mankind, but the human’s life is much higher and it makes the science possible. In this case it is impossible to make up for the breakage of elementary life conditions “/28/. The aspirations of many people are related with Europe, though exoteric sources and esoteric tradition say that Europe has no future (Spengler and others).

Political ideas and actions of the people are poor; their love affairs will be ridiculous and inappropriate; they will bring unhappy, out-of-date and stagnant atmosphere that will poison their children forever; they will share terrible thoughts and banal ideas during a party in a café.

There is no way out: to go with confidence through the life wood you should be educated, know topography, routes and methods that is you should have the idea about the space and the time and the culture you live in.

Higher education is first of all teaching culture and the system of the ideas about the world and the man developed previously to a new generation.

Thus the university education has three functions:

- I. Culture transfer.
- II. Occupation training
- III. New research and teaching science to the new people.

But **there always is the system of life ideas which is the highest time peak, the system which is the most modern. This system is culture.**

The culture controls life and is to be a completed, integral and strictly structured system any moment. It is a life plan, a guide along the wild forest of existence.

We should finish with the idle images of education and culture in which they are seen as decoration of the life of idle people”. **Modern mass- media show us only entertaining pop culture which is the antipode of the real one** as A. Hitler says that they (Slavic people) need only entertaining culture ( as vodka and tobacco) and they “will die out without any help”.

Ortega emphasizes: “Life needs culture as an integral part of man’s existence, as hands that are man's attribute.

Some people do not have hands. In this case they are not people, they are handless people. Life without culture is handless, unhappy and false. The man who lives not at the time peak lives lower a true life that is he deceives or falsifies his life with all his might.

**Today we experience the period of horrifying vulgarity despite the demonstrated satisfaction and outward appearances.** The average man might have never been as lower of his own time as he is now. That is why his existence has never been as false and fake as it is now. Nobody is in his proper place and realizes his own fate. The man deceives himself with his own tricks trying to show the world as a simple and disorderly thing...



The scientist who organized a riot in the middle of the last century, who perverted the riot belief symbol and for whom the riot is great banality and the epoch great deception should be humanized. **The scientist should stop being a barbarian who has perfect knowledge in just one subject-matter.** Fortunately, the main figures of the current generation of researchers feel the necessity in knowledge of the integral culture because of the inner demands of the science itself.

This causes the historical significance of the necessity for the university to gain the main goal back, which is to educate a person, to familiarize him with the current culture, to help him discover the huge modern world in which his life should become authentic.

**I would create the culture “faculty” as the university’s and all higher education nucleus /28/.** DonNTU has made some steps in this direction and established the Institute of Culture of DonNTU /30/.

#### **DonNTU’s experience in recreation of the Institute of Culture**

The Institute of Culture of DonNTU is the assignee of the University of Culture of DonNTU that has existed since 1959 at the former Donetsk Industrial Institute. R.I. Roitblat, an enthusiast loyal to the ideas of education, was its founder. The Institute of Culture of DonNTU started operating in May 2012. It is aimed at widening of humanitarian knowledge of students and forming of a harmonically developed future engineer. It implements the main function of the university – the cultural one. The staff is grateful to the participants and the administration of DonNTU and the Fate for the chance to work in the name of the lofty education ideals. The Institute would hardly exist without the assistance gained from the lecture centre “The New Thought”, the journal “Delfis” (Moscow), the scientific and philosophical society “The World through Culture” (Yalta) and the staff who carry out classes on a voluntary basis.

There are five trends in the work of the Institute of Culture of DonNTU:

- new trends in science;
- masterpieces of the world painting;
- masterpieces of the world cinema;
- theatre;
- music.

The speakers' geography is wide. First of all, these are professors of and academics of DonNTU, the culture representatives of Donetsk, Lugansk, Dnepropetrovsk, and Kiev regions. There were speakers from Moscow, St. Petersburg, Novosibirsk, Pskov and other cities. Cultural workers from Germany and Romania requested for making their presentations. If there are some sponsors, the plans can be implemented.

There were 200 meetings during 8 years. We would like to say personal thank you to Prof. V.V. Mirni, V.A. Svyatni, V.P. Kondrakhin, Y.F. Bulgakov, N.P. Rogozin, V.V. Prisedski, V.A. Goltsov, R.A. Dadonov, A.Y. Anoprienko, G.S. Klyagin, E.G. Kureni, D.E. Muza.

The Institute of Culture collaborates with the Museum of DonNTU. The Director of the Museum L.D. Kovalyova has made her presentations at the meetings.

The Institute has also good relationships with the studio "Sophiynist" whose students made the performances at the meetings too. We are also grateful to the Donetsk Polytechnic (a newsletter and a video-programme) and the newspaper "Vecherni Donetsk".

The Institute organizes a publishing activity. The Institute is known not only in Europe but also in the world. The cultural community of the USA proposed us to publish the book of K. Judge "Showing the Way" in Russian. The book was sent to the libraries of not only Ukraine, but Russia, Great Britain, the Netherlands, Poland and other countries.

There were performances of four Russian bards: E.A. Minaev (Moscow), I.N. Plokhov (Pskov), K.N. Yudichev (Vyatka) and A. Zvenigorodski (St. Petersburg) as well as of S. Solyoni (Donetsk), the Zolotukhins brothers (Kiev), M. Romanovski and Echo Radugi (Donetsk), the group "Tochka Tishini" (Donetsk), the group "Aquarium" (Sochi). They were a discovery for Donetsk audience. Besides, there were meetings the subject matter of which was the music of Skryabin, Mozart, Rakhmaninov, Schnittke, Bach, Chopin, and Prokofyev... All the meetings of the Institute of Culture are free. The slogan of DonNTU's Institute of Culture is "There are only one good, which is knowledge, and only one evil, which is ignorance". The operation of the Institute of Culture is aimed at eradicating of the ignorance. That is why all the meetings are free. The knowledge obtained here can not be measured.

The new productions of the films “SOS or Synthesis of General Rescue” and “The Outstanding Researchers of Ukraine” (devoted to V.V. Pack) were shown at the meetings.

Poetry: from the student S. Kliman to the professionals E. Baranova, B. Belash, V. Kalinichenko.

Theatre: the studio of DonNTU Sophiynist and the theatre-studio “Pyatoye Koleso”.

Exhibitions: the exhibition of painting reproductions “The Time Link: from Leonardo di Vinci to Nikolai Roerich” and “Man. The Earth. The Universe”. The third exhibition devoted to beauty in its all manifestations is being organized.

There were three competitions of schoolchildren’s compositions “Why Any Country Is to Keep the Culture Treasures”.

Father Nikolai (father superior of the church of St. Seraphim Sarovski) made his presentation on the orthodox photo. The talks of the representatives of clergy of other confessions are always welcome. DonNTU’s Institute of Culture is a secular organization and according to its culture position religion is included into the idea equally with science and art. We follow the behest of Patriarch Kirill: “Holy Fathers combined secular scholarship with theology and formed some synthesis. The famous theologian George Florovski called it patristic synthesis. He was dreaming about the new patristic synthesis and wanted the new generation of theologian to couple the outer secular culture with the theological creativity for the latter to be able to fertilize the culture for the words of church to be topical. I pray and hope for the dream of father George to become a reality during our lifetime”.

We are trying to implement the dream and our activity is the pray that usually starts with the words: “Sovereign Lord, teach us how I can serve your greatness”.

**Conclusions:** Here we would like to cite a Nobel Prize winner Prof. L.D. Landau: “There are natural science, unnatural science and supernatural science”. By all appearances the matter is in liberal arts and natural science that study Gnosis (Agni Yoga, theosophy and Temple of the People are not included into the world outlook and scientific apparatus because of the synthesis unacceptance). The modern science itself can not solve a number of problems and explain a number of well-known

phenomena and behaves as an ostrich that hides its head in sand. Further development of science is to have a trend of its combining with religion and arts (the two latter are very well integrated into each other). As all sciences originated from philosophy we need to study Gnostic texts that help the mankind in overcoming different crises that first of all are the world outlook ones (economics is a derivative form the world outlook). Thus the Supreme Forces expect the mankind to make a qualitative transfer that is reflected in religions as transfiguration (in Gnosis the process is called transmutation). We think it will be the transfer of homo sapiens into homo noosfericus that is the man –worker, co-creator of the space, community member, new scientist who will work not for the sake of filling his pockets but for common Good, the Good of all the elements of the noosphere of mind about which V.I. Vernadski dreamt.

#### Reference:

1. N.K.Roerich. Ways of Blessing. – Riga: Vieda, 1992. - 55p.
2. "There are no Emotions, no pathos, no Belief": fragments from the diary of V.I. Vernadski, 1932.V.I. Vernadski; publ. and preface of V.Volkov// Historic archives. – 2000.-#1. - p. 109-129.
3. S.G. Dzhura. Philosophic Approach to the Analysis of Modern Pedagogic (in application to Ukraine) // East-European Journal of Advanced Technologies, №4/2(58), 2012. - p. 23-27.
4. P. F. Belikov. The Roerichs. Practice of Spiritual Biography.
5. Agni Yoga Sides. 1955.- N.: Algym, 2011. – 704 p.  
[http://www.roerich.com/zip3/grani\\_55.zip](http://www.roerich.com/zip3/grani_55.zip)
6. L.M. Gindilis. Consciousness and its Role in the Universe: scientific, philosophical and metascientific aspects// proceedings of the X interdisciplinary scientific conference “Ethics and the Future Science” – Consciousness as a Creative Force of the Space. – M.: Delfis, 2011. – p. 5-13.
7. Kuhn T.S. The Structure of Scientific Revolutions. Chicago, 1962; M., 1975. <http://www.psylib.ukrweb.net/books/kunts01/index.htm>
8. Scientists Declare on Higgs boson creation.  
[http://www.bbc.co.uk/ukrainian/ukraine\\_in\\_russian/2012/07/120704\\_ru\\_s\\_higgs\\_boson\\_discovery.shtml](http://www.bbc.co.uk/ukrainian/ukraine_in_russian/2012/07/120704_ru_s_higgs_boson_discovery.shtml)

9. God's particle exists: physicists declare the discovery of Higgs boson. <http://techno.bigmir.net/discovery/1521536-Chastica-boga-suschestvuet--fiziki-oficial-no-ob-javili-ob-otkrytii-bozona-Higgsa>
- 10.S.G. Dzhura. On the issue of consciousness multidimensional nature //proceedings of the X interdisciplinary scientific conference "Ethics and the Future Science". Consciousness as a Creative Force of the Space. – M.: Delfis, 2011. – p. 30-39.
- 11.M.Kaku. Physics of the Impossible. – M.: Non-fiction, 2010. – 457 p.
- 12.M. Kaku. Physics of the Future. – M.: Non-fiction, 2012. – 584 p.
- 13.L.M.Gindilis. Scientific and Metascientific Knowledge. – M.: Delfis, 2012, - 576 p.
- 14.B.N. Menski. Concept of Consciousness in the Context of Quantum mechanics// Progress of Physical Sciences, 2005. v. 175, №4. –p. 413-435.
- 15.Javāharlāl Nehrū. Discovery of India. – M.: Foreign Literature Publishing House, 1955. – 434 p.
- 16.A.A. Gorbovski. Mysteries of Ancient History. – M.: Znaniye, 1971. – 534 p.
- 17.I.P. Podlasy. Energy and Information Pedagogic. – M.: data Square, 2010. – 424 p. <http://www.roerich.com/zip3/energoenergy.zip>
18. A. I. Yakovlev. Consciousness Material Nature. – M.: Infra-M, 2011. – 261 p.
- 19.N. Karr.What the Internet Does with Our Brains. – M.: BestBuisnessBooks, 2012. - 256 p.
- 20.A. P. Nikonov. Riding on a Bomb. – M.: Upgrade, 2008. – 152 p.
21. V.I. Vernadski. Philosophical Ideas of a Naturalist. – M.: Nauka, 1988. – 522 p.
22. Y. E. Kustov. Biosphere Logic // Delfis, BestBuisnessBooks, 2012. - 256 p.
- 23.S.A. Brusilovski. Do the Reliability Criteria Change when a Scientific Paradigm is Changed? // Delfis, №72, 4/2012. – p. 67.
- 24.S.A. Brusilovski. Eschatology: Myths and Reality// Delfis. 1996. . № 1(6). p. 2.
- 25.A. F. Pugach. Has the Occam's Razor Got Blunted? //Delfis. 2004. № 2(38). p .47.

- 26.L. N. Yasnitski, T.V. Danilevich. Science Modern Problems. – M.: Binom, 2011.- 294 p.
- 27.E.I. Roerich. Letters. Volume III (1935). – M.: MTR, 2001.  
[http://www.roerich.com/zip2/ei\\_3.zip](http://www.roerich.com/zip2/ei_3.zip)
- 28.José Ortega y Gasset. University Mission. - Mn.: BSU, 2005. – 104 p. <http://charko.narod.ru/tekst/ortega/ortega.pdf>
- 29.F.M. Dostoyevski. Demons. M., Pravda, 1990.
- 30.Institute of Culture of DonNTU. [http://www.roerich.com/n\\_m\\_.htm](http://www.roerich.com/n_m_.htm)
- 31.Y.M. Klyuchnikov. Why Does the World Need Heroes?  
<http://kluchnikov.roerich.com/kluchn.htm>

## 1.7. Multidimensional consciousness

**Sergey G. Dzhura**

**DonNTU, Donetsk National Technical University, Ukraine**

*The most ancient theories of human composition and consciousness and modern physical theories are analyzed. The hypothesis of combination of the world's esoteric and physical picture is reasoned. The 7-D human consciousness and bodies in the esoteric tradition is combined with 11- D modern physical theory of superstring and M-theory through the 3-D of the physical world plus the time coordinate. It is a feasible contribution in fulfillment of the Agni Yoga testament on transformation of the knowledge ancient symbols into the scientific formulae.*

Every atom has its consciousness.  
Unboundedness.§54

**Introduction.** The idea of consciousness is one of the most complicated ones. From the point of view of etymology we considered it to be the “joint knowledge” [1]. That is the knowledge someone has. Nowadays the aspiration for including the consciousness into the world's physical picture is growing [2]. This, in its turn, gives the evidence of the fact that the “physical and psychic realities are inseparable and represent only a special case of the integral space Reality which is little conscious in

its multi-D complexity” [3]. We totally agree with S.R. Ableev who says that “modern science (physics, psychology, information science) vividly floats towards the new transpersonal paradigm which is being formed. We think that the main theoretical postulate of this paradigm is as follows: the consciousness is one of the fundamental aspects of the physical reality which exists in any ontological form before appearance of the human being and gets the qualitatively new level of development at the human step of the evolution” [3]. This very wording totally agrees with the religious, esoteric, and now scientific point of view (we will discuss it further on). Thus, “The Faces of Agni Yoga” explains the fact that the knowledge existed before books. It was not put down, but was transferred in a special way to those whose consciousness could “sound” or “response” to the Consciousness of the Highest Plans of the Genesis. Thus, “The Faces of Agni Yoga” says [4]: “I state that My Closeness which is reached in the spirit gives the possibilities of endless cognition without books and even in private that is face to face by me. People rely on books too much as far as the dearest thing is concerned. It was time when there were no books, but there were those who knew and had cognized. The new knowledge comes somewhere from outside or inside, but not from books. It is the knowledge which books do not have. I speak about the ways of the direct cognition. All great thinkers, scientists, researchers and inventors went this very way and found things which could not be found in books. They thought the way the people around did not think. The new knowledge which did not depend on the printed pages was born from inside. The way of getting knowledge through feelings is the only way to gain new knowledge. However, its regular development is possible only if there is the Teacher. It will be random without the Teacher...” E. I Roerich wrote: “The earthly knowledge seems senseless and so limited. The consciousness combined with the Space Consciousness of the Lord of Heaven knows the essence of things and the meaning of everything which takes place, and sees the future” [5].

We will try to examine this amazing concept from different aspects and suggest the hypothesis of connection of the multi-dimensional consciousness with the modern 11-D physical picture.

What is available now? On the one hand it is the journal “Consciousness and Physical Reality” [2] which is related to this concept from the point of view of the official science and is open to new knowledge. It is significant that the journal “The Delphis” [6] which is always ahead of the people holding the same views has organized the conference “The Consciousness as the Creative Force of the Space” and we have the possibility to discuss this important concept. We totally agree with

the following point of view as to the consciousness [7]: “Mysticisms of all times equally saw the grand picture of the Universe structure, life, and development. According to their discoveries the Universe is multidimensional. Besides the material world there are many other worlds different from it. They are called the spatial regularities, space or plans. The spatial regularities differ by the “density” degree. So, there are “denser” worlds and “thinner” ones.

The worlds exist within one and the same volume and are so to say put into each other. At the same time the interaction of different plans is weak. The material plan is the “densest” one; the highest spatial regularity which is also called the Divine plan is the “thinnest” one.

Each spatial regularity is filled, “inhabited” by so called energies (do not confuse it with the meaning of the word ‘energy’ used in physics) which belong to the given universe plan. Energies are in continuous movement, interact with each other and change. Everything which takes place in the numerous worlds including ours is caused by the movements of these energies.

The consciousness is also a special energy. The supreme Divine plan is filled with the endless consciousness which is called the Universe Divine Consciousness. The Universe can be compared with a human being. The Universe soul is the Divine Consciousness; the body is all the worlds which exist in it” [7].

The statement of the problem

The hypothesis of the combination of the modern physical picture of the world with the esoteric doctrine applied to the consciousness phenomenon is suggested in the paper. It will be our feasible contribution to the solution of the problem suggested in Agni Yoga: “It is the time when the ancient symbols of knowledge are to transform into the scientific formulae” [8]. The essence of the problem is in the fact that theosophy speaks about 7-D consciousness, Agni Yoga – about 3-D consciousness and the modern physical picture relates to the 11-D consciousness. There is a direct contradiction the hypothesis of solution of which (that is bringing together of all the points of view) is given in the paper.

What the chief researchers have done. We totally agree with the attitude of S.R Ableev, who was the first Ph.D on the heritage of the Roerich [9]: “The concept of the multidimensional universe is fundamental for the philosophic picture of the universe of the anthropocosmism. It can be examined within three interrelated planes: in the ontological plane which assumes the existence of the cascade of the natural reality levels; in the cosmological plane which assumes the structural cosmogenesis and the global ontological evolution of the multidimensional universe; and in the



anthropological plane that assumes the multidimensional human nature and consciousness. The problem of the psychic reality nature is in the zone of intersection of these planes...

Nobody is surprised by the idea of modern physics concerning the multidimensional space. It is considered the efficient theoretical construct which explains the characteristics of micro-particles and principles of physical interactions. This idea plays the most important role in the Theory of Everything (TE) and in the superstring theory (ST). Albert Einstein is known to have created the basics of the geometrical paradigm in the physics of the XX century. He assumed the possibility of having a single physical field theory in which all nature forces are the demonstration of the single force related to the geometrical characteristics of the space-time.”

Thus, modern physics not only just admits the idea of the multidimensional space, but also is based on it as to the fundamental theories of micro-particles and great unification. This idea helped to efficiently overcome complicated theoretical obstacles and now has a status of a grand postulate...” The paper [10] is devoted to the idea of consciousness in Agni Yoga. The following postulates of Agni Yoga (6-12) are the most significant for our research [10]:

6. The Space is multidimensional; different plans of objective reality have been made by different substance forms which differ from each other by their structure and vibration level. The thinner the structure of any substance form is, the higher the level of vibration is.

7. The human body, as the entire universe, is multidimensional and has the same types of substance in the structure as the Space has. Besides the physical body there are invisible subtle material and energy and informational substrata called subtle bodies in the human body. Subtle bodies are able to serve as shells or carriers of the individual on other planes of the objective reality.

8. All objective reality planes (except for the highest two) are accessible for the human consciousness. The interaction between the consciousness and the highest spiritual planes can be done if the individual is able to coordinate the vibration level of his body and consciousness with the vibration level of the substance forming the objective reality highest planes. According to the authors of the Living Ethics the consciousness is the point where the objective reality different planes are united.

9. The interaction of the consciousness with other planes of the objective reality causes changes in the state of the consciousness.

10. The most productive forms of creativity (creative intuition, inside, flash of inspiration and other nonverbal forms of the cognition) are

based on the interaction of the consciousness of the individual with the objective reality highest planes.

11. According to Agni Yoga the consciousness has energy and informational, subtle and material nature. Brain is a tool of the consciousness activity on the objective reality physical plane. The consciousness itself is not the brain activity product despite its functions being caused by the state of brain during the terrestrial life of the individual.

12. The consciousness is able to continue the rational existence after the death of the physical body. The state and creative abilities of the consciousness between incarnations are caused by the level of its development and the karma accumulated by them. The posthumous existence of the individuals with the negative karma is characterized by moral suffering; the posthumous existence of highly spiritual individuals is the sphere of the harmonious and perfect existence with the possibilities of practically limitless creativity.”

The mentioned postulates are correlated with the research the results of which were published in the proceedings of the previous conferences “Ethics and the Future Science” [11] and in the journal “The Delphis” [12]. The following trend is a distinctive one: “History teaches us that the truth of mystical esotericism can be translated into the language of science and renew life and cognitive horizons” [11].

The modern science has already approached it and acknowledges the fact that [13] “the human multidimensional nature and autonomy of the subtle structures of informational bodies reliably explain unusual abilities of a person, that is, intuition, clairvoyance, telepathy, telekinesis, creation of bio-energetic lookalikes, and the so called “astral projection”...

This and many other mysterious phenomena should be examined as the inseparable totality of two points of view: the orthodox scientific and esoteric, that is the scientific and “parascientific” developments correlated with the science of supersensory realities and perception. This approach is related to the fact that nowadays only the work on the edge of scientific (mind) and parascientific (consciousness), shift of the attention towards unusual and unique abilities of a person, studying of the energy and informational aspects of any problem can get our cognition of the nature off the ground and bring principally new information about the surrounding.”

The Living Ethic says “the terrestrial and non-terrestrial cannot be in one dimension.” Now many theorists are sure that the concept of the multidimensional space has all the chances to be one of the cornerstones of the new paradigm of the science of the universe structure. This, in

particular, is said in the theory of multidimensional (11-D) membranes (M-theories), which is the development of the theory of superstrings.” [14]

The dialectics of the concept in mystics and in modern physics

Let us discuss the attitudes of esoteric philosophy and modern physical theories and find the characteristics which supplement each other. “Life of the Universe as that of a person consists of cycles. First the making of the worlds takes place, then they live and develop (this period lasts for billions of years), then they disappear. Everything disappears except for the Divine Consciousness which is the only one which exists during some period of time. Then the new world making takes place; everything is repeated and the regular Universe does not look like the previous one. The current Universe, by the way, is on early stage of its development (those who with inspiration are afraid of the upcoming end of the world will be upset).

The creative process goes on like this. Some part of the Divine Consciousness is compressed so much that forms all the worlds up to the material one. Some other part of the Consciousness is dispersed in the created Universe for the subsequent forming of the individual souls. The main part of the Divine Consciousness remains unchangeable and is in the highest space dimension.

The evolution of the consciousness starts after the Universe has been created. All the universe looks like “the field to grow the consciousness.” The dispersed energy of the Divine Consciousness is accumulated in the form of the clots in the lattices of hard rocks on the planets similar to our native Earth. In such a way the individual units of consciousness which are the sources of the future souls are formed. Stones have their memories due to them.” [7]

The transition from three-dimensionality to four-dimensionality is illustrated in the classical book [15]: ‘In fact, the mathematician German Minkovski and later Einstein are the supporters of the time being one more dimension of the Universe in some respect similar to the three space dimensions we are immersed in. It might sound abstracted, but the concept of time as the dimension is specific. When we want to see someone we specify where in the space we would like to see the person, for example, on the 9<sup>th</sup> floor of the building, on the corner of 53-d Street and 7<sup>th</sup> Avenue. There are three elements of information in this description (9<sup>th</sup> floor, 53-d Street, and 7<sup>th</sup> Avenue) which describe the specific place in three space dimensions of the Universe. The time of the meeting, for example three o’clock in the afternoon, is also important. This part of the information tells us where “in the time” our meeting will take place. Thus, the events are described with the four information elements: three of them show the

position in the space, and one –in the time. This data characterizes the position of the events in the space and time. In this sense the time is one more dimension. The theory of the 4-D physics is stated in the paper [16]. Here we come across that [17] “The future “Periodic System of Knowledge Elements” can turn out much more multidimensional as it is to serve all the variety of forms of the knowledge in our Picture of the World which becomes complicated very quickly.” And then: “However, during last century and a half the Picture of the World changed so much that the “accuracy” of the classical System of Knowledge is irrelevant to the reality new scale. The overcoming of the Boundlessness of the widening Picture of the World demanded for the Inaccuracy with other set of axioms under which the previous ones became a narrow particular case, and the most topical tasks became conceptually visible.”

It is supported by more ancient point of view [7]: “The goal of the individual consciousness evolution is merging with the endless Divine Consciousness that is coming back to its source not as the soul embryo but as the perfect consciousness equal to the Divine Consciousness. For the human consciousness to be perfect it needs huge attempts to develop within many lives. When the consciousness achieves perfection, it dissolves in the endless ocean of the Divine Consciousness and does not incarnate any more. When the universe comes to the end of its existence, all the worlds with everything they contain starting from the material one consequently disappear. They transform themselves into the highest energy which is absorbed by the Divine Consciousness. It also happens to the individual consciousness which have not managed to achieve the perfection yet.

Ancient mystics noticed that the consciousness in the human body can both evolve and degrade in a lifetime. Most of the people slowly evolve. The evolution can take place in two directions at once. The consciousness can grow and increase its “mass” that is the quantity of the consciousness energy. In this way the consciousness “strengthens” itself.”

The energy and informational approach is very well, from our point of view, illustrated by the paper [18]: “According to the historical fact annals many people can penetrate far beyond the visible and audible world without any devices. The person can see through the physical body with the help of the so called “third eye”. Only whole-hearted and purposeful spirits are able to do this. Spiritual vision differs from the physical one because it takes place in the energy and informational field.

The wise ancient saying says that “It is impossible to see the most important things by your eyes”. It reflects the real essence of the terrestrial human being, who is chained to his material world. If he does not come out

of it the essences remain closed to him. The hidden essences are accessible only to the spiritual vision.”

**Consciousness and brain.** The energy and information theory [18] says: “Consciousness is a common ability to think, and thinking is an attempt to solve a particular task.” If we follow this approach, we will find out that with the help of the consciousness a person comprehends the world, and with the help of thinking, which really inhabits the brain and is physiologically based, the person controls his body and everyday behavior. It is just like you cannot confuse the ability to walk with your feet.

Let us come back to the question: Where does the consciousness live? If we doubt its existence in the “head”, then where is its place?

The energy and information human being is added into the energy and information field of Earth and the Universe. We have all the information present in the Universe inside of us. We live with it. It is ours, and, at the same time, we are its part. Because of this the human being might have been named the “Microspace.” It was done not because of his complexity in organization, but because of the immediate connection to the entire immense stock of the space energy and information and the actual contents of all the stock in “himself.” *Omne mia mecum porte* (“Everything I have is on myself”) is the most ancient aphorism, which demonstrates the human being’s self-sufficiency. To tell the truth, in ancient Rome it lost its initial meaning and thesauri interpret it in the material meaning: a person has on himself everything which belongs to him. However, first of all it has its spiritual meaning. All that belongs to the human being is in himself: the information and the wealth of the Universe. Each person extracts and understands as much as he can in accordance with his thoughts and actions.

*Thinking process-* is the result of interaction of the Human-being’s information field with those of the Universe and his surroundings.

When we say ‘the surroundings’ we mean Earth as the human being’s habitat and the society he lives in. The researches aimed at finding out the dependence of scientific discoveries on the place of their carrying out (the surroundings) were made before last century. The number of discoveries and the probability of their making in the powerful information environment – large research centers, laboratories with many clever people working in them- turned out to be much higher. People become cleverer, their talents are revealed and great scientists are brought up here sooner. The effect of “nourishment” of each scientist with the energy of the common information field is obvious.

The thinking process is the interaction of the brain with the “data base” which is in the information fields of Earth and the Universe.

The English scientist E. Ackles was awarded the Noble Prize for this discovery in 1994. He studied the mechanisms of the interactivity of the human and the information fields. Our brain appeared not to have consciousness [18].

The brain has a function of the acceptor (thought invader), but not of the producer. It can't think independently, it accepts and processes somebody else's thoughts claiming they are its own.

The human's brain is just a receiver. It looks like the telephone station with the relay system which connects it to the energy and information field of the Universe.

The brain generates simple ideas as there is no need to address the space bank to solve the problem whether to eat an apple now or do it in the evening. But we cannot do without the Universe database when we deal with the really high thought products- hypotheses, theories and concepts. The "illumination" proves it. If the human works hard at the problem and does it for a long time sending continuous and more and more powerful inquiries to the Universe database it comes in the end.

Ackles's discoveries prove that the consciousness is not in the brain. It is just "the telephone station" that connects us to the energy and information field of the Universe [15].

The brain takes in the life energy from the outside (together with the human nerve centers (chakras in oriental philosophy) and generates its psychic energy on this basis. The brain is nothing without it. The psychic energy is the general, final result of the operation of our brain and body as a whole.

The results of the investigation made by P. Fenwick from London Institute of Psychiatry and S. Parina from Southampton Central Clinic were published early in 2001. The researches obtained incontrovertible evidence that human's consciousness does not depend on the brain activity and goes on living when all the processes in the brain have stopped. According to a number of researches [18] the human consciousness is not the brain function. "If it is true," Fenwick says, "the consciousness is sure to continue its existence after the body's physical death".

"When we investigate the brain", Parina writes, "We see clearly that the cells of the grey material differ in principle from other cells of the body by their structure. They produce protein and other chemical substances too, but they cannot create subjective thoughts and images that we define as the human consciousness. In the long run we need our brain only as a receiver-transformer. It operates as an "alive TV set": first it takes in the waves which come into it and then transforms them into images and sounds out of which the entire pictures are made up"[18].

The place the consciousness occupies in the energy exchange process.

The energy exchange process takes place constantly due to the absorption of the energy from outside, its processing and assimilation within the vital functions.

The quality of the consciousness can change at the same time. It can become more developed, highly organized, perfect, current, and refined. However, the consciousness of the enraged person loses its “mass”, and all the previous achievements, and degrades.

Impressions taken during the lifetime is one of the energy sources. The energy the impressions have is assimilated by the consciousness and growing soul. The growing consciousness depends on the impressions: if they are rude, the consciousness coarsens. The mystics made a very important discovery: the quality of the impressions does not depend on what the person sees or hears; it depends on how he takes it, what is derived from it. The latter depends on the consciousness state.

The mystics [7] discovered that the consciousness developed its characteristics in a certain succession, and one characteristic can be developed within even several lives.

In the incarnation line the process is as follows: in the beginning a person is “a pupil” and “an executor”. He learns how to live in the material world at this stage. Only the material plan is real to him. Everything which is behind it is unreal and abstract to him. The person develops his ability to love, sympathize, perfects his mind, and develops his firmness in certain life situations (not always pleasant). He gains independence and then feels there are other universe plans besides the material one. The religious truth becomes more and more real and meaningful to him.

In the long run (may be in many-many lives) there is the stage when the person devotes himself to the conscious self-perfection. Esotericists [7] stated that there was no need to be isolated from other people and stop the social activity. On the contrary, they think that these extremes lead the person aside the real life and do not allow him to develop a number of necessary qualities.

When the person dies, his consciousness is free from the body and is in one of the spaces outside the real world for some time. Then the regular incarnation takes place. In the process the consciousness preserves the characteristics developed within the previous lives (the developed mind, will, selfless love, greediness, cowardice, laziness etc.). However, the situations at which these characteristics were developed are erased from the

memory. Thus, the memory of the previous life does not complicate the regular new life.

Sometimes the person thinks that a reasonable force influences his life both rewarding and punishing him. But it is not true. The person himself defines and programs his future by certain actions. Some of the actions influence his fate immediately; others do it many years later. There are the actions which influence future lives only.

The mystics understand that not only the things done by the person in the material world can be called the “actions”. Thoughts, emotions, wishes, and moods are special types of energy. When the consciousness makes them, it completes the actions in other space dimensions. They also influence the outside world and the person’s further fate [7].

We totally agree with Socrates who said: “There is only one good thing which is knowledge, and only one evil- ignorance. Welfare and nobility cause only bad things.” A sinner is ignorant because of two reasons. Firstly, he does not understand all negative effects of his behavior for himself. Secondly, he cannot put in order the inner energies (he even does not feel them) which make him sin by their movement.

Psychology attitude and the hypothesis of joining of the esoteric and modern physical multidimensional picture of the world

The author of the book “Psychology of the Art” the great Russian psychologist L.S. Vygotski thought (if he is read correctly!) the person’s consciousness was the theatre, the stage where the people imprinted in us lived and acted.

The transactional analysis has the same idea. According to Eric Bern there are three persons in us. To be exact, there are many different people in us, and three hypostases “I” can be marked out: “a Parent”, “an adult”, and “a child”. From our point of view it is the trinity analog of the immortal individuality that according to the ancient tradition comes from incarnation to incarnation (“We won’t die, but we’ll change”, Christ said). This issue is widely discussed. We would like to give a typical example [19]. John Glidman in his essay “Scientists in Search of the Soul” published in the proceedings of July 1982 wrote: “From Berkley to Paris, from London to Princeton famous scientist working in the fields of neurophysiology and quantum physics say not only in private, but also publicly that they believe at least in the possibility of the immortal human being’s spirit.”

Glidman mentions Charles Popper, “the most famous philosopher of the century who is the author of the orthodox theory of scientific background that is held by the majority of researches.” He postulated ‘the existence of immaterial conscious intellect which influences tangible



substance.” The famous physiologist Charles Sherrington put forward the same suppositions.

As to physicists, some of the representatives of the science made the similar conclusion. John von Neumann “whose intellect was great” wrote about the immaterial consciousness able to influence the substance in his paper on quantum mechanics published in the 30s. “It was only in the beginning of the 60s that one of the greatest physicists of our century Eugene Wigner who was awarded the Nobel Prize in 1963 was brave to put forward the theory which Neumann’s followers were secretly discussing at their laboratories...”

Sigmund Freud was one of the first to form the idea of the complicated stratification of the psychic world. Before that the consciousness, as a rule, had been perceived in the psychic aspect. For example, in W. Wundt’s model the consciousness was interpreted as a field with concentric circles. He put clear and distinct views of the consciousness in the center, and vague and little-conscious ones- in the periphery [20].

We think that the “regularity” increase, including the consciousness is also presented in 7D composition (and consciousness) of the human being.

The ability to change the degree of complementarity of the consciousness states with respect to each other is an important specific feature of the consciousness quantum model [21] in contrast to quantum mechanics.

The quotation from the book “7-D Composition of Human Being” [22]:

“Human being consists of seven types (or dimensions, or bodies, depending on interpretation) of different density substance. Only one part out of the seven, which is our physical dense body, is visible. Other six parts are inaccessible to the usual physical feelings. There are people, so called clairvoyants, who see one or some of other parts depending on the level of their spiritual development.” What are these parts?

Elena Ivanovna Roerich wrote to her collaborators [23]: “I made small additions to the 7-D classification of human being.

1. Physical body.
2. Air double (called the lowest astral body). Many phenomena are made by the medium’s air double during séances.
3. Prana- a life principle which is indivisible from all Space events.
4. Kama – animal soul (or the higher astral body through which the wish in two aspects is shown):
  - a) Kama-Manas –the lowest mind or intellect.

b) Kama-Rupa – the form (the subjective form of mental and physical wishes and thoughts, or the thinker in operation).

5. Manas- the self-consciousness or thinker (the Highest Intellect).

6. Buddhi- spirituality, the spiritual soul – in contrast to the human-animal soul- the conductor through which Atma is shown.

7. Atma-Spirit- fiery source, or energy spread in the Space” [23]. The schemes of human being’s dimensionality are given in the figure 1.

Fig.2 shows the hypothesis of combination of the 7-D and 11-D picture of the world (consciousness). It totally agrees (or at least does not contradict) with the concept put forward in [3]: “The Space Consciousness after Blavatskaya also correlates to the nature reality levels. In other words, it is on all seven main space being planes [24]. However, only four lower planes are potentially accessible to the developed human-being’s consciousness [25]. We think that the accessibility is to be understood in both cognitive and psychical aspects.” [3] And further on: “The philosophical language of the Living Ethics –Agni Yoga is sure to have oriental terminology and original stylistics as compared with theosophy. However, on some parameters it is easier and more understandable than the theosophical text language of the XIX century. Thus, the theosophical seven- level system of the ontological patterns of the space reality in the Living Ethics is transformed into the simpler three- level model. These reality levels are called the “Dense World”, “Fine World”, and “Fiery World” [3]. The first four principles (three coordinates and the time see fig.2 – the principles 8,9,10 and 11 entering one) are the analog of the Dense World for our 11-D space model. The principles 2.3.4 (there is no time in them according to Agni Yoga) are the analog of the Fine World (or soul). In fact we do not perceive it in our dreams (when we enter it for a short time). The “Fiery World” is the principles 5, 6, 7 (fig.1). It is the analog of Holy Trinity (Immortal Spirit) or Monad.

Thus, in the jubilee year of the space flight we understood that the immortal triad (principles 5, 6, and 7) flies into the space as a rocket. That is, let us imagine a human being (his principles are in the fig. 1) flying into the space as the rocket when his life is over. The lower quarter (principles 1, 2, 3, and 4) are the steps that separate themselves on the first day of leaving (the 1<sup>st</sup> principle), no later than the 9<sup>th</sup> day of the leaving (the 2<sup>nd</sup> principle), no later than the 40<sup>th</sup> day ( the 3-d principle), no later than a year ( the 4<sup>th</sup> principle). So, the human being could be imagined as a spacecraft flying into the eternity of the transitions among incarnations where the lowest principles are the steps of the ordinary spacecraft separated on the first day (a physical body), no later than the 9<sup>th</sup> day (an air double), no later

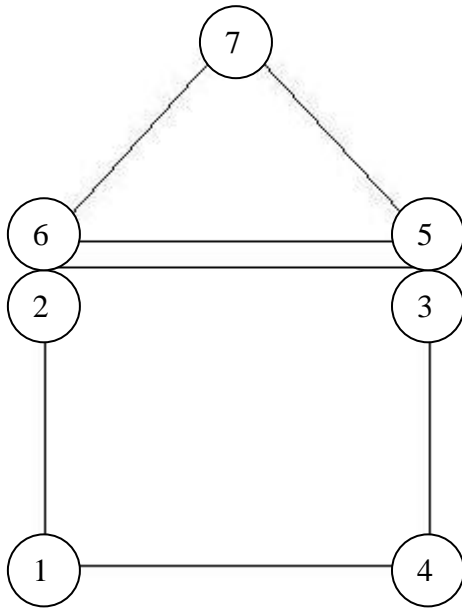

Fig.1. Human being's esoteric scheme.  
consciousness hypothesis.

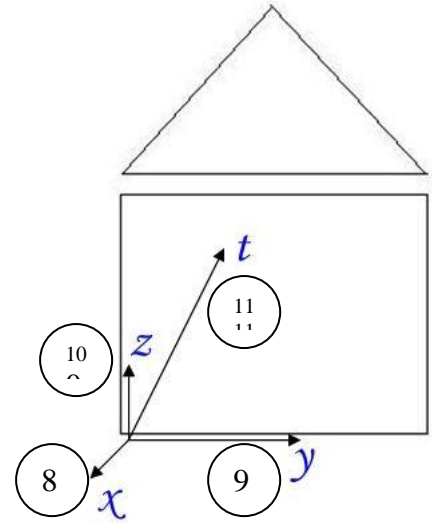

Fig.2. Multidimensional  
consciousness hypothesis.

than the 40<sup>th</sup> day (an astral body) and a year (a mental body) leading the immortal triad into other being spaces. The spacemen present at the conference mentioned in their presentation preamble that the things they were going to speak about had been prohibited to speak about for several last decades. The world-view issues related to each human being are frankly put forward in the paper.

The modern psychology researches support the point of view [26]. They assert that “Our karma is our consciousness” [26].

### **Human being as a multistep rocket of unboundedness**

Let us have thorough examination of the world physical picture genesis. The physical world has three dimensions (four, to be exact, including the time). Einstein's papers showed that the time could be considered as one dimension more (“the future-past”) that makes up four general dimensions (three space dimensions and one time dimension). Green [15] wrote: “The supposition that our Universe can have more than three space dimensions can seem senseless, eccentric, or mystical. However, in fact, it is quite real and carefully grounded. This feature of the Universe is so natural and fundamental that usually it is not even mentioned. However, in 1919 the unknown Polish mathematician Theodor Kaluza from Konigsberg University dared to challenge the evident. He supposed that the Universe could have more than three dimensions.

Sometimes the suppositions that sound senseless are just like that. Sometimes they shock physics backgrounds. Though the supposition of Kaluza took some time to be recognized, it made the revolution in the physical law forming. We still can hear the echo of this prophet's insight." Klein made the idea more precise: "In the paper which Kaluza sent to Einstein in 1919 he made a surprising supposition. Kaluza stated the spatial structure of the Universe could have more dimensions known to us from our life experience. As we found out very soon, the motive for that radical hypothesis had been the fact that it had allowed to build an elegant and powerful device that had combined the general relativity theory of Einstein and the electromagnetic field theory of Maxwell into one uniform conceptual system. But how can this supposition be coordinated with the vivid fact that we see three spatial dimensions exactly?" [15]. Here one analog more is to be mentioned. Agni Yoga says about the principal difference between the reality and evidence: "There are two truths: the truth of the dense world, the evidence truth, and that of the space, the reality truth. Both of them are equally convincing. Only on you depends which of them to choose. You will live with the one you give the preference to. It will be the only truth to you. The chosen truth focus will attract the facts and proofs that support the chosen way. The world outside us is as soft as wax for the spirit: it sees what he wants to see in it. The one who wants to see the Light sees the Light, the one who wants to see the dark, does it. When those who thought me to be God's Light honored me and saw the Light in me, others asked: "Is there the devil in you?" as we perceive in ourselves through the light or darkness. You are to be brave and turn to the Light with all your strength of mind. The old person in you is persistent to pull your consciousness back. Two focuses of attraction act violently: one strives for the Light, for me, for the future, the other one- backwards, for the past, for the small "I" that does not want the Light. You will be torn by the two until you leave the old person that is the past heritage and overcome him. The task is extremely difficult as the old person in the person is strong and lasting. It replaces the reality by the dense world's evidence. It is it that makes the visibility to be considered the only reality. However, it is mortal in you. So put him face to face with the death when everything he lives and surrounds himself by collapses. The reality truth looks into the person's eyes and destroys the world of temporary illusions or demonstrates the impossibility to keep it. Take this old person in yourself behind the death and ask how he is going to live without being filled up with what he is filled up now, that worries him and that he is tied to so violently. When all dense constructions are destroyed, his kingdom is destroyed too for the person to be left with the brash. No! Do not allow him to be taken up in the hands of

hopelessness as the world created by him is to be destroyed and die.” [27] This proves the esoteric knowledge of modern investigations. And further on [15]: “The answer which Kaluza’s paper contains not in the implicit form and which was clearly given later by the Swedish mathematician Oscar Klein in 1926 is in the fact that our Universe space structure can have both spread and compressed dimensions. This means that our Universe has the dimensions which are spatial, spread and easily accessible for observance like the length of the garden hose described in [15]. However, like the cyclic dimension of the hole, the Universe can contain additional spatial dimensions which are tightly compressed in a very small area which is so small that it cannot be found even by the most modern experimental equipment” [12]. This is a complete proof of the esoteric doctrine of the multidimensional Universe (including the space and consciousness). And the final quotation: “The latest achievements showed that the mentioned components played an important role in the string theory which is a part of the grander synthesis which has a little bit mystical title M-theory” [15]. This commanded synthesis is really to be done. It was not without reason that the name of Roerich’s Teacher started in the letter “M”. “Recognition is a Synthesis. The Synthesis is the generalization of the processes of the Visible and Invisible Being. Knowledge is a limited step of cognition. The cognition is beyond the Time and Space. The Consciousness grows with the Synthesis. It cannot move forward narrowly. The movement of the consciousness covers new circles starting from the center. The Space law is firm, but enlightened by a thought and thus is reasonable” [28].

**Conclusions.** The paper combines the modern physical picture of the world (multidimensional consciousness) and the ancient esoteric doctrine. The solution of this external contradiction is theoretical so far and needs to be experimentally proved although it will be very difficult to do it as to the consciousness. However, the hypothesis exists. Let it be a small step forward to comprehend the great idea of Consciousness which leads the mankind to the evolution. There following idea exists not without reason: “It is a SINGLE LIFE, which is eternal, invisible, and, at the same time, omnipresent, having neither beginning, nor end, but periodical in its regular manifestations, among which the darkness of the mystery of Non-being rules; the unconscious and at the same time Absolute Consciousness, incomprehensible single self-existing Reality; a real Chaos for feelings, the Space for the intellect. The esoteric language calls its single absolute characteristic, continuous Movement, the Great Breathing which is the unceasing movement of the Universe in the sense of limitless ever-existing Space. Which has no movement cannot be Divine. In fact, and in the

reality, there is not anything which is absolutely motionless in the Universal Soul.”[27] And the final thing [4]: “The time when the secret mysteries of the nature and the Highest knowledge that only great Teachers have now will be accessible for the masses is yet to come. Those ahead who are led by the Light Lords and, first of all, Great Teachers who come to the earth from time to time and live among people lead the mankind to it. They have the only goal- to give the knowledge to people in such a way that they are not able to abuse it. The danger of the abuse is big. They might destroy the Earth. That is why only few, selected, reliable and tested during many thousands of years of the joint work are led by the roads of the direct cognition. Only they are trusted and are given through.” We will try to deserve the knowledge and will strictly obey the Covenants.

### References:

1. S.G. Dzhura. Practice of Teaching the World Outlook Aspects of Agni Yoga in the Course “Computers and Programming”// in the book “Humanization of Education at a Technical University. Proceedings of the Regional Scientific and Methodological Conference, Donetsk, DSTU, 1994.
2. Journal “Consciousness and Physical Reality”. <http://sfr.folium.ru>
3. S.R. Ableev. Consciousness Universum. Philosophical Problems of Consciousness in Euro-Asian Antropcosmism. - Tula: Papirus, 2009. 4.
4. Agni Yoga Sides. 1955. – Novosibirsk: Algim, 2010.  
[http://www.roerich.com/zip3/grani\\_55.zip](http://www.roerich.com/zip3/grani_55.zip)
5. E.I. Roerich. Fiery Experience: at the Threshold of the New World. – M.: the Roerich’s International Centre, 2000.
6. Journal “Delfis”. <http://delphis.ru>
7. Consciousness Evolution in the Multidimensional Universe.  
<http://istina.rin.ru/cgi-bin/print.pl?id=2416&p=0&sait=4>
8. Agni Yoga, Brotherhood, p.1, 425.  
<http://www.roerich.com/zip/ay.zip>
9. S.R. Ableev. Structure of the Natural Reality: being, Consciousness, Illusion.// Proceedings of the IX International Inter-Disciplinary Conference “Ethics and the Future Science”, “Knowledge Paradigm and Education”. - M.: Delfis, 2011.
10. N.E. Kovalyova. Consciousness Phenomenon in Agni Yoga.- M.: Ripol Classic, 2007. [http://www.roerich.com/zip3/fenomen\\_sn.zip](http://www.roerich.com/zip3/fenomen_sn.zip) /
11. I.A. Gerasimova. Problems of Understanding of Space Ideas/ IX International Inter-Disciplinary Conference “Ethics and the Future

- Science”, “Knowledge Paradigm and Education”, Moscow, 23-24 march, 2010.
- 12.N.V. Bashkova. About Consciousness Development (in philosophical anthropology and pedagogic of Agni Yoga)// №4 (64), 2010. – p. 114-118.
  - 13.V.A. Rostakov. Youth Mystery Elixir/Delfis, №3 (63), 2010.
  - 14.A.V. Zubko. Being Bearing Bosom. Delfis, №3 (63), 2010.
  - 15.B. Grin. Elegant Universe. – M.: KOmKNiga, 2007.  
[http://www.roerich.com/zip3/elegant\\_universe.zip](http://www.roerich.com/zip3/elegant_universe.zip)
  - 16.S.V. Chernov. Four-dimensional World Physics. - M.: Sputnik, 2010.
  - 17.A.S. Narinyani. Knowledge System and Boundlessness: Visible and Invisible/ Issues of Artificial Intelligence, №2, 2010.
  - 18.I.P. Podlasi. Energy and Informational Pedagogic (Text-book). – M.: Data square, 2010. <http://www.roerich.com/zip3/energoenergy.zip>
  - 19.S. Krenston, K. Willams. Reincarnation. New Horizons in Religion and Science. - M.: Sphera, 2001.  
<http://www.roerich.com/zip3/perevop.zip/>
  - 20.L. E. Motorina. Philosophical Anthropology. \_.: Academic Project, 2003.
  - 21.V.I. Moiseev. Consciousness Quantum Model. - M.: Editorial YPCC, 2004.
  - 22.Septenary Composition of Man.  
[http://www.roerich.com/zip3/nfo\\_75.zip](http://www.roerich.com/zip3/nfo_75.zip)
  - 23.E.I. Roerich. Letters. Volume III (1935). - M.: MTR, 2001.  
[http://www.roerich.com/zip2/ei\\_3.zip](http://www.roerich.com/zip2/ei_3.zip)
  - 24.E.P. Blavatskaya. Mystery Doctrine. V.2.  
<http://www.roerich.com/zip/td2.zip>
  - 25.E. P. Blavatskaya. Mystery Doctrine. v. 3.  
<http://www.roerich.com/zip/td3.zip>
  - 26.L.V. Raichenko, S.N. Raichenko S.N. Philosophers' Stone or Esoteric Psychology Foundation. - Donetsk: DonNTU's Institute of Culture. – 2011. <http://www.roerich.com/zip3/fs.zip>
  - 27.Sides of Agni Yoga.1957.Novosibirsk: Algim. 2008.  
[http://www.roerich.com/zip3/grani\\_57.zip](http://www.roerich.com/zip3/grani_57.zip)
  - 28.E.P. Blavatskaya. Mystery Doctrine. v. 1.  
<http://www.roerich.com/zip/td1part1.zip>

## Chapter 2. Civilization Risks

### 2.1. Risk challenges of the present

S.G. Dzhura, V.V. Otkidach, V.I. Chursinov

The easiest way to subdue the nature is to  
obey it.

Francis Bacon.

The ideas of the world integrity and that of scientific knowledge about it show that the further progress in the world understanding is not so much in further differentiation and deepening of knowledge in very narrow majors as in the knowledge integration and system presentation of objects, processes and phenomena. It is necessary to master the scientific world outlook and integral principles of description of the objects, the phenomena, the processes, and system laws and regularities /1/. This proves the necessity of the idea of synthesis in science that can help solving previously insoluble problems by other methods and will show the way to a new paradigm. Let us discuss some aspects of this problem in the light of risk information and energy processes on the Earth planet.

**Energy and information risks** All the world moves. Atoms, molecules, cells, organisms, biological and social systems also move. There are different motion forms: mechanical, thermal, chemical, electromagnetic and others. We understand after thorough studying that these are different forms of a single interrelated process of energy transformations.

Paper /2/ proves that, besides the thermal equivalent measured in calories, energy types differ in the ability to do work. Thus, energy is informative and information is power producing. The information carries the energy in general and of different quality: the energy of both creation and destruction. In this respect the Internet has a possibility to influence energy processes in individuals and communities in different countries. So, the Internet has a **role of “information intensifier”** and feeds user’s request by the information and transfers it into the aggregate of the structured information (e.g. e-library) /3/. Thus, there is the universal



instrument- an analogue of the intellectual process intensifier that makes the efficient influence on the best informed people and through them on the surroundings and so on. The process is a serious risk as the information in the Internet (about 80%) is anti-evolutional /4/. It is the first information risk of intensifying of the processes that contradict the man's evolution. But there are other sides of the phenomenon: today the Internet is **a new signal system of the mankind** that crucially widens the possibilities of the coordinated team influence. It is a positive moment as evolution ideas and processes are implemented through the Internet very fast (the world narcobusiness, terrorism, prostitution, slave trade etc.).

**The risk of creation of the world empire** It is the first time when the possibility of creation of the world empire- a conqueror's dream- has appeared. The previous attempts collapsed from the informational point of view (the army went too far and the conquered territories are impossible to be ruled fast). The size of the empires is known to be limited by the so-called "transport theorem: the sizes of the empire can not exceed  $v \cdot t$ , where  $v$  is the speed of the information movement, and  $t$ - the typical duration of the processes subject to control from the centre.  $V$  becomes conditionally endless in the Internet and there is the first ever possibility to create the world empire. This is taking place now. The Internet and the world globalization were spoken about at one and the same time. The question is the globalization of what people wanted to build. Whether it is the globalization of violence, money pumping, total control etc or the unprecedented possibility of cooperation, coordination of evolution processes for the benefit of all countries and joint cultural construction. Only the inner culture of the man helps him to separate the wheat from the chaff. Isn't the safety insurance, resistance to negative processes and cultural mutual enrichment the decent goal of the project? But, unfortunately, there is much less examples of the latter than the former one...Thus, the country in the military department of which the Internet had been born did not fail to create the empire or the police state of the future. The CIA has published the Strategic Investment Plan for Intelligence Community Analysis recently. The spies acknowledge that they did not completely use the possibilities of open sources and the work with them is to be the investment priority. Now the CIA logically supposes that it is safer and cheaper to get the information from the open sources

rather than from intelligence. The Internet is a not ploughed land in this sense. People will say everything about themselves. The CIA is not a monopolist in using the programmes of such class.

**The risk noosphere aspects or virtual risks.** What risks are these? For example, information wars. An American political scientist /6/ says that a cold war with Russia has not finished yet. More than that, it is becoming stronger. It is proved by the fact that the USA has broken the signed agreements (the one on anti-missile defense of 1972) unilaterally and promises (on not moving of the NATO towards the east). We do not speak about the “controlled” elections in many countries and the special attention the USA pays to the CIN countries. The author /6/ drives to the conclusion that it would be more profitable for the USA to support Russia in order to avoid the risks of stopping controlling nuclear and other weapons Russia has in sufficient amount as in case of the situation destabilizing terrorist would get access to the most modern systems of mass-destruction weapons. Isn't it the risk of nowadays? Besides, the idea of democracy and human rights is an argument that can be discussed in different ways as the definitions of them are vague and can not be considered academic. That is, they can be interpreted in the way suitable for the world hegemon of the present. And it is one more risk of deviating from the world evolution processes.

**Entering the above level** The authors have already tried to examine the issue of the evolution algorithms and drove to the conclusion that despite the genius of the researcher it is impossible to solve the risk problems without entering some above level (according to Gödel's theorem ). Otherwise we might deviate from the mankind's evolution main track. Turning to the esoteric concept the clauses of which are entering the scientific circulation can be such entering the **above level**. The international conference “Ethics and the Future Science” /8/ is devoted to entering of different aspects of the methodology into the scientific circulation. S.R. Ableev, the first Doctor of Science who defended his dissertation on the Roerich's heritage, made an unprecedented step towards understanding of the esoteric doctrine in the light of philosophy. In his book/11/ the author overcomes the traditional European centrism of science and gives a profound report on the oriental and Russian thought and cultural and historical phenomenon of esoteric philosophy. The

reasonability of the approach is proved by the joint Russian-Ukrainian work /10/ in which there is a place for both the traditional scientific paradigm and the esoteric methodology.

**The crusade against culture** The thesis is competent. Neither military nor economic aggression could destroy Russia (Belarus and Ukraine too). Apologists and followers (in terms of esoterism) of evil forces could do nothing with the states. The only thing they have to do is to destroy the culture, and then the ideas of patriotism, spirituality and feat might leave the youth aspiration and the countries can be won with bare hands. Unfortunately, the doctrine belonging to Z. Brzeziński, works! It was he who said that they “were going to deprave the youth, to make teachers the society pariahs and to make money and sex the only ideals of the youth”. This is **today’s greatest risk and the challenge to the mankind** as according to the esoteric concept the existence of peace on the Earth planet depends on the existence of Russia. E.I. Roerich wrote: “**The revival of Russia is the revival of the entire world.** The death of Russia is the death of the entire world. Some people begin to understand it, although all people thought that the death of Russia would save the world. The fear of growth of Russia was big and nobody could find the real reason of it. People were frightened of attacks made by Russia and nobody foresaw the effects of the explosion the detonation of which was to explode the range of other seats. The effect of Russia explosion is big. The clouds are running from the north to the south. Russia is undergoing a great trial and is having its lesson which it will learn earlier than others”/11/. It is very close to the slavic soul and differs from the transatlantic approach which is implemented purposely in the CIN countries.

The people that have only left-sided thinking developed might not understand that **this crusade against culture is to be stopped for the sake of all countries.** Thus, it is profitable for the world and for the development (and existence) of the USA to support sustainability of Russia. It is a thankless thing to dictate others what to do and how ...

You should start from yourself. This, according to the esoteric doctrine, starts the way to perfection. One of the most complete Internet libraries Oriflamma (<http://www.roerich.com/>) on synthesis of science, religion and philosophy is to help. The visitors from Russia, the USA and Ukraine are among those who visit it very often. Some international

projects (including the association “Ethics and the Future Science”) make the exchange of evolution information public through the Internet. There are computer disks for those who do not have access to the Internet: <http://roerich.com/dvd.htm>. We think that we should look for the ways of integration and finding a compromise to develop a new world scientific paradigm helping solve such risks as anthropological, ecological and energy catastrophes that will definitely lead to the spiritual revival, development of the synthetic scientific paradigm of the XXI century for our children to live on the Earth planet and for the life chain not to be broken. A catastrophe and a crisis can be of both negative (if proper conclusions were not made) and positive (if they were made) nature. Now we have an opportunity to make correct conclusions. The Internet might help us do it. Its educational significance has not been evaluated properly so far. We should turn to the idea of the Teacher and recollect the words of V.I. Vernadski: “**A scientific thought** (under the correct course of the state work) is not to run into the state force as it is **the main source of people’s wealth, the basis of the state power**, and struggle with it is a painful and temporary phenomenon in a political system” /12/.

V.I. Vernadski has many other methodological aspects that fully coincide with the esoteric methodology. For example, the doctrine of Agni Yoga speaks about man as the universe energy transformer. V.I. Vernadski says: “The biosphere can be considered the area of the Earth crust covered with transformers that convert space radiation into the active earth energy – electrical, chemical, mechanical, thermal, etc” /13/. As far as the attitude to the science and its role for the state is concerned we should learn from our transatlantic colleagues that were able to organize the work of corresponding branches in the way that helped the USA become a super-state. The USA was lagging behind the Old World. It was only when its scientist began working better that it won the competitor and the progenitor. Now the process is going on in the form of “green cards” and other better conditions for researchers and capable of working population at the expense of other countries. The USA does not pay for education and bringing up in this case. More than that, it does not pay for the birth and formation of a researcher either. All costs are covered by the motherland of the researcher.

As far as other analogy between the traditional and esoteric doctrines is concerned we would like to cite V.I. Vernadski (his work “Essays of Geochemistry”): “With the appearance of man a huge geological force appeared on the surface of our planet”/14/. The doctrine of Agni Yoga says: “My friend, do not make an earthquake!” /15/. There is an absolutely different state of affairs in the development of the American system HAARP which is on the military base in Alaska. The real goal of the project is to burn space and other objects by active plasma. Potential possibilities of influence of the systems of this type (there are at least four of them in the world) on growth of natural and climatic catastrophes and anomalous occurrences of the global scale are under active discussions today. These are hurricanes, tsunami, and snow in the equatorial areas, floods, droughts and global warming. In 2002 the Russian federation addressed to the Congress of the USA with the proposal to ban further tests of the HAARP system because of unpredictable consequences of the “research” for the mankind /16/. We wonder why the USA is surprised at hurricanes that cover the territory of the USA so often. There is a saying: “He who sows the wind will crop a storm”...

V.I. Vernadski says about the necessity of a spiritual life for the existence of science: “If we want to understand the growth and the development of science, we should take into account all other manifestations of the spiritual life of the mankind. It’s inevitable. Destruction of any activity of human’s consciousness causes depression of other one. Discontinuance of man’s activity in the field of art, religion, philosophy or a public life will affect science. Thus, we do not know the science (and the world understanding) which exists apart from other spheres of man’s activity. And as far as all the aspects of man’s soul are necessary for its development they are the growth medium from which it draws its vital forces and the atmosphere in which research takes place”/17/. The authors gave more detailed information on the subject “V.I.Vernadski and the East” in paper /18/ that emphasized that variety give sustainability not only to countries and species. The variety can also be a cultural one.

**Wrong choice risks.** There are special risks at turning points of the mankind’s existence when it is to make its choice. It is general culture and such parts of it as safety culture that can help. The risk under discussion is

especially vivid during presidential elections. Transatlantic technologists are good at it and push the public to the choice necessary for them. Three Russian academicians illustrated it in their book /2/. Have a look at the bifurcation diagram in fig.1.

It shows the state of affairs in a blessed faraway kingdom called The Country of Blockheads. We will show time on the horizontal axis, and the income per blockhead on the vertical one. The blockheads lived happily till the time  $\lambda_1$ . Then they started thinking whether to create their own blockheading industry or to remain an agrarian and raw material appendage for their neighbours.

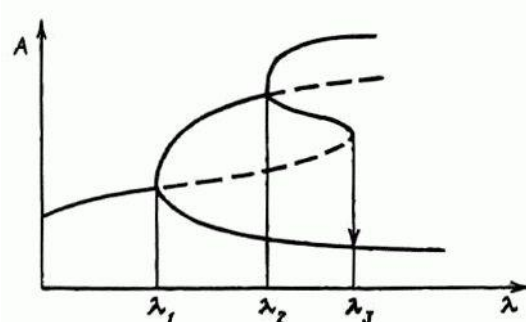

Fig. 1. Collision of the phantom with the trajectory of sustainable development of the Country of Blockheads after which disastrous changes take place

They drove to the conclusion to support the first version and moved towards the future along the upper branch. Here they were covered by a wave of technical progress just in the point  $\lambda_2$ , and again they had to decide whether to make frying pans and excavators or computers with VCRs and artificial intelligence. They thought they had enough intelligence, and the frying pans were just the case. They started dreaming about different fantasies (what about we are not sure) and their written language disappeared. The case with frying pans was getting worse and worse too and they started recollecting the old times and common values. Time  $\lambda_3$  arrived and the blockheads lost their understanding on what was going on. When the smoke lifted it appeared that they had already become the agrarian appendage and the neighbours taught them life and sent

humanitarian aid. It looks like the post-perestroika processes in the CIN countries.

Unfortunately, these bifurcation moments can easily “correct” the course of a country, and the democracy actions in this direction are quite vivid. Many text-books in computer engineering suppress the fact that the first European computer was made in Kiev (the former USSR). A great number of the USSR priorities including this sphere made the foundation of TV program cycle called “Unbelievable Things which are Obvious”.

**Risk esoteric aspects.** We think that the esoteric synthetic paradigm can find methodological solutions to the risk problems. The risk methodology implies the following: the worse, the better. There is a famous saying: “The pike exists for the carp not to snap”. E.I. Roerich gives a brighter proof: “The thought on material wealth are the most destructive on the way of service for the Light. No one of the true followers of the Light doctrine has died in poverty so far. All the doctrines show **the ruin of provision or safety**. Greek philosophers stated that **the provision was the destruction**. It is true as a well-to-do person is calm and does not strain his abilities. The spiritual death comes when the person stops straining and leaves his aspirations alone as the great strain feeds psychic energy” /11/. The methodology is easily understood by an oriental person and is difficult to get by a Western European one. The Internet virtual world gives a chance to exchange the opinions, discuss the problem thoroughly and to make a reasonable decision. It is one of the problems discussed on philosophical forums in the Internet (<http://forum.roerich.com/>). The person of American culture thinks that he will achieve the goal of his existence when he builds the civilization. It is one more risk of the wrong choice (in its axiological sense) of the development direction.

Many scientists think that the American civilization has already passed the return point of understanding of permanent value of every culture. Esoteric philosophy sums up: “The civilization has forced the idea of culture out. Many people do not understand that it is possible to be a civilized barbarian. We miss the fact that later developments of culture are accumulated for centuries, but the civilization can be formed within a decade” /11/. It is also reasonable to take into account the balance of the golden mean at the stage: the choice or a lot (determinancy or stochasticity as karma or a conscious choice in the idea of risk).

**Educational risks.** N. R. Roerich said: “The source of all the evil of the world is ignorance”. The USA copied our model of education which had been the best one. Now they are trying to impose theirs from the economic point of view. The approach of the USA to the problem (Bolivar is not able to carry two people) has already passed the return point where there is understanding that every culture but not only the American one, which is the so -called pattern to follow, is permanent value for the entire world. More and more people in the world understand it especially after the poor policy of the administration of George Bush (we do not speak about their illiteracy and ignorance). Thus, we **see serious risk of not sufficient education of the people that rule.** If an uneducated and ill-bred person does not have a leading position, the harm he can do is minimal, and vice versa. It is topical for many countries, but the maximal risk appears when the uneducated president rules not only his own country but tries to govern the world. We would like our words to look like not as anti-American attack. We have been to America and have very warm memories about meetings with the people living there. They are hard working and deserve different future (from the one they are being led to). The problem is that they have such unworthy politicians (even for a while). It is the problem that not only the USA faces... The prompt E.I. Roerich made to the President Roosevelt is an interesting historic moment (the independence of the country was received with the help of oriental Teachers). When Mr. Roosevelt followed the advice of the Great Lord everything went well for the USA. The process stopped at some moment. E.I. Roerich wrote: “Well, my dear, work at understanding it and remember that **nothing different can save America from an awful way.** Only acceptance of it will bring the rescue. So *act* with understanding it. The shield of the Great Lord is only where his orders are obeyed. Everybody including new workers such as Galahad\* should understand it and *the corresponding measures should be taken.* Do not allow our boxes be empty in all senses!” /11/. Sooner or later the conscious choice (but not the “democratic” juggling) should triumph over. Having made the correct choice the mankind will enter a new epoch (the Golden Age according to the ancient wisdom). Nowadays many terms are misinterpreted. The word ‘esoteric’ has a meaning of something

---

\* Henry Agard Wallace (1888-1965) the Minister of Agriculture of the USA in 1933-1940, the Vice-President in the administration of F. Roosevelt in 1941-1945.



forbidden and not scientific. Many terms that had had a positive meaning gained the negative one: love, motherland, patriotism... But it is a subject of a separate research.

Let us come back to the subject-matter of the Internet. Every great invention has two sides, two opposite supplies. Creating a problem the great invention offers the tool to solve it at the same time. The Internet search of identity, keeping and multiplication of the culture spelled with a capital letter is and needs to be opposed to the globalization information pressure made through the Internet. Virtual trips help solve the problem of permanent value of cultures of different nations and their including into the world cultural tradition. International evolution Internet projects are aimed at it. The projects of the authors of the paper /18/ made their feasible contribution into the process. Thus, the Internet as a gigantic storage of the information becomes the means of people' organization. For the Internet is more important not only to know more, but also to organize and coordinate large masses of people and more complicated processes and thus to raise energetic power of a human team. According to esoteric sources to raise the energetic power we need to understand the culture as N. K. Roerich did. E.I. Roerich whom N.K. Roerich called his Chief wrote about risks and the Earth planet state: "Our planet can end its existence by a giant explosion. The crucial hour for the Judgment day is not far off. Many children will live that long. That is why the doctrine of the Lord M. is given so fast and so many unusual signs fall down the Earth. But people are blind and deaf! The human's spirit is to be woken up! The fate of the earth planet is in the hands of the mankind! If the spirit revives within forthcoming little decades, the inevitable catastrophe might be partial as at the times of Lemuria and Atlantis, otherwise we will have to migrate to another planet. According to the law of equivalence and commensurability the majority of the mankind will not be allowed to the highest already populated planets. They will have to adapt to the new world which is not populated yet, and many millions of years will have passed before new covers and forms corresponding to the new world are formed. Only some groups of the Earth's mankind will be able to arrive to the new planets and continue the evolution under new and nice conditions. The Great brotherhood is taking extreme measures to save the planet from untimely death. The underground fire is very active and the number of the dangerous energy dischargers is

too small. There is no ridiculous destruction in the space; everything has its own reason. The great REASONABILITY rules in the space; everything that can not go with the evolution is considered to be the space waste and processed. Thus, it's up to the man and his free will which application is to be chosen. Now he is making heaps of waste that might absorb him completely if the spirit is not revived in time. The time has already arrived” /11/.

To sum up we would like to say that the development of the modern paradigm is unreal without the esoteric concept being included into it. We support the idea of the author /12/ that the idea of spirituality is to be included into the category tool of the modern science that will happen when the new scientific paradigm consisting of new knowledge that are not explained by the present paradigm is developed. The esoteric position of existence of Russia (including all the countries of the CIN) is very important. The slogan of St. Segiy “Help Russia!” is very topical now. Understanding of the future of our countries is connected to the wide cultural and scientific collaboration and understanding of the permanent ideas. The way out of the most complicated system crisis is in understanding of the processes. The current conference shows that the mankind will come out of the situation with credit.

#### References:

1. I.V. Prangishvili. Entropic and Other Systems Regularities: issues of Control of Complex Systems/ I.V. Prangishvili, Institute of Control Problems named after A. Trapeznikov. - M: Nauka, 2003. - 428 p.
2. L. G. Melnik. Fundamental Basics of Development. – Sumy: ITD “Universitetskaya Kniga”, 2003. – 288 p.
3. I.O. Odintsov. Professional Programming. System Approach. St.P.: BHV 2004.- 624 p.
4. S.G. Dzhura. Social Aspects of Virtual Reality // Man in the Social World: Problems, Research and Outlooks. Scientific and Practical Newsletter. Issue 2002/2 (№9). – Tula: NII MP RAEN. - p.78-80. <http://www.roerich.com/zip2/social.zip>
5. V. Pekar. New Babylon // CHIP №2, 2006. – 34 p.

6. Stephen Cohen. America is Starting a New “Cold War”  
<http://forum.msk.ru/print.html?id=11956>

7. A.Y. Anoprienko, S.G. Dzhura, V.V. Otkidach. Evolution Algorithm of the Universe// Man in the Social World: Problems, Research and Outlooks. Scientific and Practical Newsletter. Issue 2006/1 (№16). – Tula: NII MP RAEN. - p.4-10. <http://www.roerich.com/zip3/evolution.zip>

8. International Non-Governmental Association “Ethics and the Future Science” <http://ethics.roerich.com/>

9. S.R. Ableev. History of the World Philosophy. – M.: Publishing House “Astrel”, 2002. – 416 p. [http://www.roerich.com/new\\_phil.htm](http://www.roerich.com/new_phil.htm)

10. Wisdom of the Earth Home. About the World Outlook of the XXI Century. Ecogeosophic Almanac, issue 4-5. Edited by V.A. Zubakov. St. Petersburg – Donetsk, 2003; <http://www.roerich.com/zip2/almanah.zip>

11. E.I. Roerich. Letters. V.3. – M.: MTR, 2001. - 518 p. [http://www.roerich.com/zip2/ei\\_3.zip](http://www.roerich.com/zip2/ei_3.zip)

12. V.I. Vernadski. Scientific Thought as the Planetary Phenomenon // Biosphere and Noosphere. - M.: Airis-press, 2004. - 576 p. [http://www.roerich.com/zip3/vern\\_bio.zip](http://www.roerich.com/zip3/vern_bio.zip)

13. V.I. Vernadski. Biosphere Doctrine, Noosphere Dream // Biosphere and Noosphere. M.: Airis-press, 2004. - 576 p. [http://www.roerich.com/zip3/vern\\_bio.zip](http://www.roerich.com/zip3/vern_bio.zip)

14. V.I. Vernadski. Essays on Geochemistry. M., 1983. – p.258.

15. Hierarchy. §166. - <http://www.roerich.com/zip/ierarhia.zip>

16. V.I. Kuzmin, N.A. Galusha. Nikola Tesla and Power of the Future // “Delphis” №2, 2006. – p. 54-63.

17. V.I. Vernadski. Biosphere and Noosphere. – M.: Airis –press, 2004; [http://www.roerich.com/zip3/vern\\_bio.zip](http://www.roerich.com/zip3/vern_bio.zip) /

18. S.G. Dzhura. Social Aspects of the Internet Communication //Delphis №4 (40), 2004, Moscow. - p. 94-98. [http://www.roerich.com/zip2/s\\_a\\_icom.zip](http://www.roerich.com/zip2/s_a_icom.zip)

19. V.V. Otkidach, S.G. Dzhura, V.I. Chursinov. Risks of the Evolution Noospheric Stage // Proceedings of the Scientific Conference “Creative Heritage of V.I. Vernadski and the Present. – Donetsk: DonNTU, 2005, –p. 233-237

20. S. P. Kapitsa, S.P. Kurdyumov, G.G. Malinetski, Synergetic and the Future Forecasts. – M.: Editorial URSS, 2003. - 228 p.

21. Y. Cherepakhin. Anatomy of Belief // Academy of Trinitarism. - <http://www.trinitas.ru/rus/doc/0021/001a/00211079.htm#ptr-nt1>

## **2.2. Esoterism of the idea of time and time risks of the modern civilization**

A.Y. Anoprienko, S.G. Dzhura

The paper surveys the idea of time in its classical meaning and the esoteric aspect. It is done on the materials of the DVD “Oriflamma” or its Internet version– roerich.com that includes more than 1000 references on the synthesis of science, religion and philosophy and is one of the most complete in the Internet. We would like to discuss the influence of time on the crisis moments in the history of the civilization. We will also speak on the development of the idea of the time risk and goal of the civilization movement. We will rely on scientific branches and esoteric knowledge and give the classification of closely related concepts and the outlooks of influence of the concept on the crises of the modern civilization on the imaginary time scale that will help for better understanding of the reason and driving to the corresponding conclusions (if they are certainly heard).

We would like to start the survey with the classical definition of time: “Space and time are general forms of matter existence; the space is the form of existence of material objects and processes (it characterizes structural properties and length of material systems); the time is the form of successive change of phenomenon and states of the matter (it characterizes the length of their being). The space and the time have an objective nature, are inseparable from the matter and closely connected with its motion and each other and have qualitative and quantitative endlessness” /11/.

According to the definitions and conclusions made by one of the outstanding mathematicians of the CIN countries V.V. Puck in his book /2/ we can say that: “If to make a long time forecast for the mankind’s development (and to evaluate the risks), the interval on the time arrow is to be as big as possible (fig.1). The interval that official science covers is not sufficient as vector 2 and vectors 1 here diverge greatly if to take into

account the data which the mankind assimilated as legends, parables and religion spheres etc”.

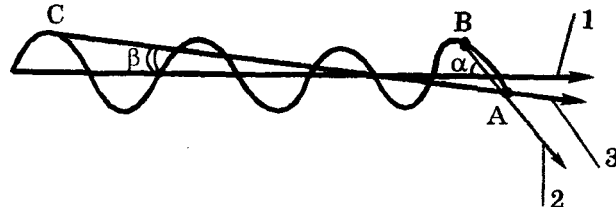

*Fig.1. Short (2) and long (3) forecasts, the motion direction (1))*

Thus, if to rely only on definition and distance covered by the official science, it is impossible to make an accurate forecast as to the risks of the modern civilization. It can hardly be satisfactory without taking into account other science groundwork that covers much bigger distance of existence of the mankind as a species. These sciences are called esoteric and they are getting very active in scientific practice. The conference is one more important step on the way of science integration. V.V. pack wrote in his paper “From the Golden Age to the Golden Age”/4/: “Races that integrated with us will give a start to the VI civilization and close the eight thousandth cycle of the Earth. This space mission of eastern Slavs being the leader of the epoch of Aquarius bringing the mankind to the third millennium was predicted by Max Heindel about a hundred years ago. He wrote: With the sun entering Aquarius the Russians and Slavic race will reach the level of spiritual development that will move them much higher the current state. The spirituality is to develop with intellect and through it. Slavic race existence will be short but it will be great and happy as it will be born from great sorrow and unspeakable sufferings. The compensation law will bring to the nation that forms the last of seven subraces of Aryan epoch. The Slavic civilization will be the basis for the development of the VI race of the mankind”.

The above said is a scientific prognostication made by the representative of the traditional science who can think nontraditionally. As to the time characteristics he says the following /4/: “Changing the time we change the space which has different parameters inside living and thinking creatures”.

It coincides with the point of view of Boltzmann who relates the growth of entropy in the Universe with the “time arrow” directed from the past to the future ( the time moves forward because the entropy grows constantly. But the information is anti-entropy and its influence on the time is opposite.

Thus while the man is thinking he is winding up the clock of the Universe and prolongs its life!

It is the information influence on the space that explains practically all parapsychological phenomena that official science is going on refusing to have anything to do with...

The poet S. Marshak wrote: “I know that the time is extendable and it depends on what contents it is filled with!”

Why the time is so slow in our childhood? Because everything is new and interesting for a child. It learns much every minute and the time slows down. In our old age we are bored, we have already seen much and the information passes our consciousness without a trace and the time is pressed implacably. That is why if you want to live long, move your brains! One more scientist working at DonNTU Dr A. Anoprienko developed the ideas in a number of papers ([6-8]):

What can be taken as C point: 1991, 1918 or 1654? All the years are significant: declaration of the independence of Ukraine, formation of the first independent state of Ukraine and the Council of Pereyaslav. No, it's too close. Let us step eight thousand years back! What can we see on the territory of Ukraine?

According to archeological digs there was the most ancient state of the world called Aratta on the territory of the North Pre-Roman Crimea and Dnieper Ukraine eight thousand years ago. It became the centre of the Trypillian archeological culture (originated from the village Tripillya near Kiev) that made crucial influence on forming of Aryan community and the single parent language from which all languages of Indo-European group branched off.

The name of the state (close to the Ukrainian verb “to sow”) says that its inhabitants were settled, farmed and bred cattle. They were the first to discover bronze, handle dogs and horses, use an arrow, a bow and a sling for hunting and defending from unbidden guests and wild animals. They

lived in peace and harmony with neighbours and the nature which they worshiped.

The Aryans did not know slavery, were engaged in the “individual work”, and were under priests-brahmans that collected and kept wisdom and created Rigveda and other Vedic sources. The Supreme God of the Aryans was Dzyaus – the forerunner of Greek Zeus, Slavic Div, Indian Dyaus.

The necessity to define the farming terms raised their interest in astronomy. Cult constructions of the Aryans are observatories in which brahmans observed the rise of the heavenly bodies which look like Stonehenge (Great Britain) but are two thousand years older!

The God Visnu was one of the most honoured Aryan and later on Indian Gods. He was the Lord of space and time, and associate of Indra (Indra) – the main character of Rigveda and its main myth on liberation of Val – the New Year’s germ of the Universe.

Taurus, Bull, the appearance of whom Dzyaus, Zeus, Div, and Jupiter can have is the astrological sign of Aratta (and Ukraine!). The succession can not be an accident as well as the fact that six thousand years later the first advocate of Christianity in the North Pre-Roman Crimea was Andrew the Apostle. He finished his Earthly life in Greece and as Christ was crucified on the oblique cross that became the symbol of the highest Russian order of Andrew the Apostle and the marine flag (Andreevski).

By that time Aratta had stopped its existence. The Aryans were against any violence, and because of martial Romans they left for the south-west through Caucasus and Middle East on the territory of modern Iran and India. They left as memories the names of territories, rivers, lakes and cities behind themselves. For example, Tripolye in Ukraine, Tripoli in Livia (the territory of Ancient Egypt), Tripura in India etc.

You are sure paid attention how the names of our rivers are in harmony with each other: the Dnieper (the Danapri with the Aryans), the Dniester, the Danube, the Desna, the Don. It is no mere chance as all of them originate from Aryan Dan (the beginning, the source). You can give a number of such examples yourself if you have some maps at hand.

The state of the Aryans existed on the territory of the North Pre-Roman Crimea for the record period of time as it was the first state of free people for whom violence was alien and that implemented their astrological sign of Taurus in an optimal way! India where the majority of the Aryans moved gains its independence in non-violent way.

The Golden Age of classless existence of the mankind finished with the Aryans leaving Europe, and Arrata's derivatives Greece, Rome, ancient Egypt and Sumer were slave states. Some part of the Aryans remained in Europe. For example, the ancient Celts or Gaels are direct heirs of the Aryans. They lived on the territory of modern France, Belgium, Switzerland, south Germany, Austria, Italy, Spain, the British Isles etc. in the first century B.C. The priestly caste of the Druids that were the leaders' advisors, kept wisdom as the brahmins did and acted as judges were very influential. Nowadays everybody knows the popular Gaul horoscope the symbols of which are trees.

A small part of the Aryans that lived on the bank of the Ros river – the right tributary of the Dnieper – started the Rus' people that later on split into the Great Russians, Little Russians and Belorussians.

Millenniums and epochs have changed since then. We are lucky to be not only their witnesses but also the participants of the change of not only a century, a millennium and an epoch ( the epoch of opposition of Pisces is changed by the epoch of collaboration of Aquarius ), but also of the civilizations: the sixth Earth civilization of kind genii that have magic characteristics will come at the beginning of the XXI century. They do not need plants, the transport, communication means, computers and other attributes of the fifth civilization that thoroughly improved its production tools and hampered the development of the Homo sapiens as a species (in the respect we did not move further the Cro-Magnons that lived forty thousand years ago!).

What does the line drawn from the point C to the point A say (see fig. 1.)? It says that Ukraine as well as our brothers Great and Bela Ros will enter a new society of the European states. Several generations of the Taurus land will live without war and conflicts as Taurus is characterized by patience, efficiency, absence of aggression and individualism. It is useless to drive the nation into a common flock. The Ukrainian is an owner,



a farmer, an entrepreneur, a scientist-encyclopaedist ( like V.I. Vernadski) and a healer in his soul. That is why he should be given a chance to realize himself in his own way by using his natural characteristics.

The interested reader will make his own conclusions, find the books in the Internet and see a number of interesting mathematical graphs related to the idea of time made by V.V. Puck at the edge of the traditional and the esoteric science that opened the way to other researchers working in the field.

You can get about 640 links related to the idea of time if you use the CD of Oriflamma. The works of N.A. Kozyrev are among them.

Thus there are many characteristics of the time that include a number of puzzles the solution of which can be found in sciences which the traditional one has forgotten unfairly. We will turn to them to find the references for understanding of this complex philosophical concept.

We will turn to the fundamental reference book on Agni Yoga (in three volumes) written by the Ukrainian State Prize winner Prof. A. I. Ryzhenkov [9]. When there is a critical number of works like this, there might be some changes in the consciousness of people and they will have the world outlook the mankind of the XXI century deserves.

Here we would like to give a brief review of the esoteric concept of the time.

The concept of the time itself is connected with many others and can not be examined separately. For example, the phrase from Theogenesis about the time which is a “feeling illusion” connects the concept of the time with that of illusion (Mara) etc.

The reference book divides the concept into such parts as the Great Time, the Time of Maitreya, the Fiery Time, the Discord time, the Time of Shambala, the Poisonous Times, the Premature Life, the Time Absorber, and the Time which Presses.

In general the time can be classified according to the meaning of its concept:

- on the Earth and in the Subtle World;
- the time is a sorcerer;
- the time is a magician;

- the time is a great screener.

We will talk about the most typical ones.

The Fiery World (part 2 §346) says: “There are 2 types of people. For the first one the time drags, for the second one it flies. The latter has the developed characteristics of the Subtle and Fiery World. They can work all the time. Can you imagine someone working all the time if he is pressed by the time? You can liberate yourself from the time pressure by the compact existence. The matter is not only in constant work, but in such transfer of the consciousness into the future when you do not have enough time for difficult thoughts”.

The time is taken in our and the Overhead World in the following way (The Overhead § 575): “Urusvati knows that there is no time in its earthly meaning in the Overhead World. There are terms based on inevitable consequences. The evidence of the earthly time can not be found among the truest insights. The overhead terms are characterized by some close attendant event. The evidence only shows that the Overhead Worlds forecast the event course without mentioning the so-called time. The sensitive consciousness will be able to remember the data on the attendant event and recognize the rest.

A human being can understand the non-existent time even during his earthly life. He does not know the time when he rushes to something very important. This pressure prevails in the Overhead World. We can be deep in the work and forget about the time. It is said that concentrated work contributes to longevity. It gives a birth to harmony and helps to get overhead knowledge. It knows the events in its logical and chemical meaning. We should always remember that chemism promotes every phenomenon.

Here is one more page of our inner life. We strive for something to be in harmony with the Overhead World. We do not evaluate the time itself. The event essence, its flow and coordination are of extreme significance. We inform on the event importance in an understandable form. Everybody is to feel the essence as it includes the ability to be calm. One of the philosophers said: “Strive for the thing essence and you will understand the truth of the Universe”.

The time length. “Brotherhood §291”: It is extremely difficult to take the instantaneity of action of a subtle body. People are connected with the

relative concept of the time so closely that they are unable to get rid of the time length. Only those who got used to enter the Subtle World know how much it is possible to feel instantly. Every sense is to be preserved.

“The Overhead §208” : Urusvati knows how instant and unexpected visions can be. People can especially be impressed by the visions of alive people and those whom they do not know. There are many reason for the visions. They might be familiar to you as you might have seen them in the Subtle World. The same vibration might also cause the mutual vision.

If people wrote down their visions and told proper people about them many things would have been revealed. But it is these observations that remain in vain and our consciousness loses the chance of the visual intensification. For example, one person was playing the piano somewhere. It caused vibration that sounded in Urusvati’s consciousness. The vision of the unknown person was formed in such a way. These consonances are important for the fiery tissue. People touch each other in accords and some collaboration takes place.

Many vision instantaneity is explained by the law of the Subtle World: there is no earthly time. The vision transiency is seeming as the human being can see in the conditions of the compact world in which subtle images fly very quickly. But when we are in the Subtle World we are not influenced by such instantaneity. We just enter mental spheres and subtle existence and take the subtle as the natural thing. The Subtle World increases our experience and thus we understand the earthly swiftness.

The philosopher paid attention to the difference in perception of the compact and subtle worlds. He said: “ Some unseen creatures rush around us. Only light blow reveals their presence. Sometimes they form a blue cloud around us. We are practically unable to recognize the strangers. But we are going to welcome them and open our hearts for them to send us assistance from their nice spaces”.

Our time characteristics: “Unboundedness §11”: “Those who know the future are moving towards the evolution. Those who are afraid of the evolution are moving to death. They will ask about rise and fall and will be surprised by the evolution course. The evolution course can be explained by understanding of the space waves. When you recognize that a beautiful flower can be born from ash, you will understand that only weak-spirited consciousness is afraid of destroying. The space movement has waves.

Some deep waves could have been avoided and the evolution could have been accelerated. Indifferent people do not know the movement and enjoy only temporary flourishing and do not understand things that can lead to our planet collapse.

Those who are building now, please, understand that you are building for destroying! Your undertakings are huge, and your castles are unnecessary! Your expenses are so big! Your inability to enter the chain of actions is so instructive! But let us have a look to those who go in an orderly manner, who strengthen the beauty of the Unboundedness. Unlike the weak-spirited denying the space influence, they understand achievements, and their wishes are nice. That is why we say that space phenomena are infinite!”

We should also say some words about folklore and people’s wisdom. There are some famous proverbs and saying related to the time concept: “Time is the great healer. Everything in its time. One can’t turn back the clock. An hour in the morning is worth two in the evening.” They can help in understanding of the concept.

As to the traditional science we are happy to say that the scientific events of the journal Delphis (seminars, conferences etc.) are of great help. We can mention the proceedings published in the year of Russia in Ukraine devoted to the 300<sup>th</sup> anniversary of St. Petersburg and V.I. Vernadski in which there are papers of the Noble Prize nominees and serious developments of esoteric nature.

Conclusions: To overcome a temporary crisis of the modern civilization you should have a clear understanding of the time concept in its traditional and esoteric interpretation. The time interval for forecasts and definition of the goals for each person, nation, country and the entire mankind is to be as much as possible. Here we can’t do without the data given by esoteric sciences the materials of which are put into operation of the traditional science. This combination, according to the authors, will bring success to the common future of the Earth planet. The future generations will have Agni Yoga doctrine, and its ever-burning fire will turn the Boat of the Time (the lively word of the truth) back.

## References:

1. The Soviet Encyclopaedia Dictionary. – M.: Soviet Encyclopaedia, 1988. - 1600 p.
2. V.V. Puck. “Puzzles of the Space, Time and Being”/  
<http://www.roerich.com/zip/zagadki.zip>
3. V.V. Puck. Engineer, Mathematics and Others. Simple Methods of Mathematical Modeling of Natural and Technological Processes. – Donetsk: Novy Mir. - 1995. - 224 p.
4. V.V. Puck. From the Golden Century to the Golden Century /  
[http://www.roerich.com/zip/nauka\\_24.zip](http://www.roerich.com/zip/nauka_24.zip)
5. V.V. Puck. Fragments of the book About the Physical Nature of the Pure Forces and Devilry / [http://www.agni-age.net/zip/pak\\_sila.zip](http://www.agni-age.net/zip/pak_sila.zip)
6. A. Y. Anoprienko. Cognitive Mega-Maps: Practice of Reconstruction of Culture Forming Models and Images of the World // Proceedings of Donetsk National Technical University. Issue 39. Series “Information Science, Cybernetics and Computer Engineering” (IKVT 2002). – Donetsk: DonNTU. – 2002. – p. 206-201.
7. A. Y. Anoprienko. Astro-morphic Factor in Post-engineering // Proceedings of Donetsk State Technical University. Issue 10. Series “Problems of Modeling and Automation of Design of Dynamic Systems” – Donetsk: DonSTU. – 1999. – P. 89.
8. Anoprienko A. Interpretation of Some Artifacts as Special Simulation Tools and Environments / “Short Papers Proceedings of the 1997 European Simulation Multiconference ESM'97. Istanbul, June 1-4, 1997” - Istanbul, SCS, 1997, p. 23-26.
9. A. I. Ryzhenko, N.G. Tolmachev. Agni Yoga. Reference Book in three volumes. – X.: Torsing, 2002/ [http://www.agni-age.net/zip/sprav\\_ay.zip](http://www.agni-age.net/zip/sprav_ay.zip)
10. V. A. Zubakov. Wisdom of the Earth Home (about the World Outlook of the XXI Century) St. Pb, 2003 - - <http://www.agni-age.net/zip/maneb.zip>

### 2.3. Energy Risk Control

(devoted to the 150<sup>th</sup> anniversary of Nikola Tesla )

A. P. Kovalev, S.G. Dzhura, L.V. Chernikova.

*New approaches as to the development of the ideas of N. Tesla whose 150th anniversary is going to be celebrated in 2006 are examined in the paper. The perspectives of the development of power engineering technologies are analyzed, and approaches to N. Tesla's ideas implementation to create ecologically pure and safe energy sources are shown, the ways of energy risk control under these conditions are demonstrated.*

According to the analysis of the current processes and the forecasts based on computer modeling the world system characteristics are changing cardinally. We are on the threshold of the changes that, as to their scale and significance, can be compared with the Neolithic revolution. The previous year speed of the Earth population increase was in proportion to the square of its number. The growth rate stabilization will occur during the nearest ten year periods, and then the number of the population, according to the expert assessment, will reach 10-14 billion people. Now the mankind is passing one of the main bifurcations of its history. That is why the goals of development, algorithms of their achievement, spiritual, social, and economic spheres must be changed in the main. The new reality is going to be born /1/.

The current situation makes us speak not about separate problems, but about the loss of sustainability of the branch of the bifurcation diagram that defines the current development of the world community. The Vice-President of the USA A. Gore called the present "system deadlock" leading to the radical changes and to the transfer to the new reality "the crisis of the market-consuming civilization".

The mankind can not refuse the majority of dangerous technologies so far. This typical situation can be illustrated by the modern state of power engineering. The mankind annually burns the amount of fossil fuel equal to that which the nature needs to produce during one million years. The

general power consumption in the world rose from  $21 \times 10^{18}$  joule in 1900 to  $318 \times 10^{18}$  joule in 1988. Coal, oil and natural gas, which are non-renewable energy sources, make up 88% of the world power budget. The balance is covered by nuclear energy (in France the share approaches 70%). Alternative energy sources can not be a serious alternative. That is why we will have to use the results of dangerous technologies and come across the consequences of their application in the foreseeable future /1/. From our point of view the scientific development of ecological energy sector risks is the priority problem. The paper shows the possible ways of its solving.

There are several areas of ecological energy sector. The so-called non-traditional technologies (the sun, floods, geothermal energy etc) can not exceed 10% of demands according to the most optimistic assessments. Hydrogen energetics is rather a promising one, but it is not more efficient than the current nature contaminating one from the economic point of view. Bioenergetics based on rape processing is one of the areas. The projects partially implemented in the past and left as hints on the paper and non-finished constructions created by scientist of genius Nikola Tesla are more promising. All the energetic of the past century and the current one is based on his works. His 150<sup>th</sup> anniversary is going to be celebrated on June 10<sup>th</sup> 2006.

The bibliography reference book /2/ gives only brief information: Nikola TESLA (10.07.1856—7.01.1943): a Serbian researcher in electronics and radio engineering. He was born in Smelyani (Croatia). He graduated from Polytechnic Institute in Gradec (1878) and Paris University (1880). He worked as an engineer in Budapest, in Paris (1882-1884), at the plants of Edison and Westinghouse since 1884. N. Tesla developed a number of designs of polyphase (mainly two-phase) generators, electric engines and transformers and the schemes of transfer and distribution of polyphase current. In 1888 (independently of Ferraris) he discovered the phenomenon of the rotating magnetic field, and constructed electric generators with the frequency of 5000-20000 Hz on its basis in 1889-1990.

The scientist researched the possibility of wireless transfer of signals and energy for a long distance and in 1899 he demonstrated lamps and engines operating without wires on the high-frequency currents. He also constructed a number of radio-controlled self-propelled mechanisms. N. Tesla studied physiological influence of the high-frequency currents. In

1899 he built a 200 kilowatt radio station in Colorado and a 57.6 m radio aerial in Long-Island. He also invented an electric sensor, a frequency counter etc.

However, the current works devoted to N. Tesla are more significant /3, 4/. The XX century was rich in great minds, but the talent and work results of N. Tesla are more amazing. His contemporaries such as Kelvin, Relay, Einstein, Bell, Heaviside, Westinghouse, and Edison appreciated his works very much. The research in rotating magnetic field, creation of the first induction electric engines and polyphase transformers made him popular in scientific and engineering circles. Thomas Edison recognized his talent immediately and proposed him working in his laboratory. But the young student was better than his teacher. It was the energy transfer and transformation systems designed by N. Tesla that were recognized more suitable for implementation. It was the start of the “worldwide electrification”.

The engineers, researchers and industrialists who knew N. Tesla personally were influenced by this thin, dark-haired man with a pointed face. It was the charm of the person of genius that gave a birth to the feeling of involvement to the reveal of the great mysteries of the nature, touching of the Unknown. He did not use the equations of electrodynamics of Maxwell in his calculations. But it did not prevent the leading scientific and research centres from 13 cities (Paris, Vienna and Prague) from awarding him with titles of honour. By the way, the analysis of Maxwell equations made by Z.I. Doctorovich quite recently (the journal “Consciousness and Physical Reality, v.1, №3, 1996) proved that this basis of modern electrodynamics has a number of irresistible contradictions and paradoxes.

Not many people know that, according to the patent certificates kept in the USA, it is Tesla (not Marconi) that has the priority in the radio invention. He was also the first in the modern technologies of information hidden transfer when high frequencies are used.

N. Tesla’s works were extremely ahead of his time. The physics of the phenomena he was researching was and is on the border of modern knowledge and technological potential. He studied resonant phenomena in high and low frequencies and ultrahigh voltage. Unfortunately, only some descriptions of his installations (one of them resonated with the earth ionosphere) are preserved. There are some attempts to understand and



simulate their supposed characteristics. But an experiment can not be substituted by anything in the field of unknown physical phenomena. Some results got by him and demonstrated to public are not achieved now. Just think of his getting of globular discharge! Its mystic nature has been discussed up to now. N. Tesla's first experiments on wireless power transfer, which is done practically without any losses, are still a mystery and the priority task of science. His contemporaries witness that he was driving an electric car with a power source of extremely high capacity /3/.

Now there are some materials on N. Tesla's puzzles the Russian Academy of Science, the Russian Academy of Natural Science, and the Russian Academy of Cosmonautics named after K. E. Tsiolkowski, the Association ELKWANT etc. dealt with /4/.

There are two not decoded and not implemented problems N. Tesla worked at that are preserved. One of them hints on the direct connection between gravitation and electromagnetism. C. Huygens, I. Newton, M. Lomonosov, H. Lorentz, D. Maxwell, D. Mendeleev, A. Poincaré, L. de Broglie, P. Lebedev, P. Dirac, Y. Zeldovich, A. Sakharov, A. Migdal, A. Logunov etc. were working at it. The other one is related to the efficient long distance wireless transfer of power on microwave channels. Both are related to the unknown nature of gravitation, friction, inertia, vacuum structure and charge mobility /5/. Both problems were not implemented in the XX century. At present, when we have the results of the set of the statistic data on thermodynamics of kinetics in its phase transfer of liquid, hard and gas environment with taking into account the analysis of the efficiency of the complete closed circuit of energy and mass exchange, conjugated non-linear structures from charge production to its distribution and transformation into useful work, Tesla's ideas are being recognized. A number of quantum- relativistic versions of the cycle efficiency complex (closed) examination were built:

energy resources ->power -> useful product!!

Thus, power is the central scientific and technological problem of power engineering in the XXI century /5/. N. Tesla's gravitation and electromagnetic model versions are given in /6/. In Tesla's times there were no modern interpretations and versions on the mechanisms of origin of electric charge itself, of its transfer and transformation into useful work, no terms of functional characteristics of the kinetics of origin and transfer of

the charge in semiconducting environment on the level of micro-macro interactions. The proofs were obtained later –through many experiments when gravitation and energy and mass exchange in respect to space weightlessness conditions was studied. It is interesting to know that N. Tesla was guided by alternative physics in which there was a place for the universe air /3/. We will not discuss it in the paper. We will discuss energy risk control issues.

Last years of his life N. Tesla lived all alone and carried out his experiments on a yacht far in the open ocean. He invented a three phase generator and installed the transformer to generate the lightning of more than 10 kilowatt and send it on 50 km. The main dream of Tesla was the wireless transfer of energy to any point of the world. We think that ecologically pure energy of the earth planet can be created on the basis of principles developed by Tesla. To do it the naturally recharged capacitor—the ion sphere of the Earth planet and the other pole can be used. It is extremely important now when we understand the necessity of the crucial change of principles of getting and using of energy. On August 5<sup>th</sup> 2005 «The Financial Times» wrote: “The world will come across huge energy problems. The only thing is clear: the epoch of the legal oil is finished. We encourage scientists, academics, politicians and statesmen, experts in the environment protection, leading industrial companies and every person to take part in creation of a new energy epoch. Delay is inadmissible”. N. Tesla was right when he tried to hide his most interesting discoveries as he understood the mankind would use them to destroy other people...

The leading world countries started developing the weapons based on new physical principles in the second half of the XX century. Geophysical, plasma and psychotropic weapon was dominant. The research done with the plasma weapon the operation of which is caused by the ion sphere activating was the most impressive.

The results of such impact cause the breakage of the communication, control and navigation systems and can lead to global geophysical catastrophes. Such systems were extended by the USA in Alaska (a military base within 450 km from Anchorage). The name of the station was abbreviated to HAARP — High Frequency Active Auroral Research Program. The system radiation capacity in the frequency range of 2.8-10 MHz is 1.7 megawatt (10 gig watt according to other data). Its antennas

directed to the zenith focus impulses of short-wave radiation at some parts of the ion sphere and heat them to form the high-temperature plasma /7/.

Analogous systems were extended in Greenland, Norway, Costa Rica and Australia. The station capacity in Norway is by a factor of ten bigger than in Alaska, the capacity of the station in Greenland is comparable to that of Alaska.

The potential impact of the HAARP type systems on the boom of natural and climatic catastrophes and anomalous phenomena of the planetary scale (hurricanes, tsunami, earthquakes, snow in equatorial areas, droughts, floods and the global warming) is under discussion now.

We will not touch the problems of efficient application of the HAARP type systems to intercept rockets and break the communication systems. We will discuss the objective reality of the dangers the mankind faces because of the powerful impact on the ionosphere made by the stations situated in the polar zone.

The part of the ion sphere that contains layers reflecting radio waves is unstable from time to time and explodes a huge amount of energy into the upper atmosphere of high latitudes /8,9/. The geophysical “weapon” of the type uses the system of unstable state of the Earth layers (solid, liquid and gaseous), effects of the resonant increase and distribution of disturbances with low decay that initiates disastrous results registered for these layers. Thus effects of resonant increase of electromagnetic atmospheric noise in the spherical hole between the earth planet and the ion sphere were predicted and experimentally discovered at the second half of the XX century (they are called Schumann resonances). The wave is spread at a speed that is close to that of light and has a very low disturbance (0.1-0.4 dB/1000 km).

The main source of the noise excitation is vertical lightning charges /10/. It proves the potential of spreading of signals of anthropogenic nature according to the Schumann resonance mechanism far from the place of their generation. N. Tesla developed this long distance energy transfer at the end of the XIX century.

The ionosphere is, of course, a moderator between the space and solar radiations the entries of which are in the circumpolar areas on the one hand, and between the uneven irregular flows coming from the earth surface in accordance with the ring structures on the other.

The ionosphere, the height of which is 400 km, provides the interaction among the bodies having incomparably big sizes and is the membrane working in a very busy mode. The extreme characteristics of the inner impacts are enough to cause the global droughts, fires and floods that make the mankind to struggle for surviving.

The current anthropogenic system, which is million times more powerful than critical levels of natural disturbances, is able to destroy the fine border between the conditions of the biosphere existence and their absence.

HAARP stations are in the zones of maximum reactions of the planetary level on the disturbances generated here. The impact of the experiments made at the HAARP on anthropogenic and natural and climatic catastrophes has been discussed for a long time. Thus there were some experiments on the impact made on the ionosphere at the station on August 14<sup>th</sup> 2003 /11/.

The date went down the history of the New World as the “black Monday” as the entire system of energy supply to the eastern coast of Canada and the USA was blocked.

In 2002 the State Duma of Russia turned to the US Congress with the proposal to ban further experiments on the HAARP stations because of unpredictable results affecting the mankind. It proved the localization of the zones of catastrophes registered after such ‘experiments’ at the HAARP in Alaska.

The overwhelming majority of analogous geophysical catastrophes occurred in the USA. A number of hurricanes occurring in the Caribbean Sea and coming to the eastern coast of the USA in 2004 were of maximum intensity in the spherical triangular among the ring structures. There were 11 hurricanes in the Atlantic in 2004, and there were 17 of them during 9 months of 2005. The maximum damage caused by the hurricane Allison in 2001 made up 3150 mln USD, the hurricanes happened in 2004 caused the damage assessed as 6-10 billion of USD each. The hurricane Katrina started in the region in 2005 caused the damages on 200 billion of USD. The hurricane occurred in the Indian Ocean at the end of December 2004 was in the critical zone of the earth surface which is in the spherical triangular of icosahedral and dodecahedral model /11/.

Thin films are characterized by a special phase state of substance. It is them that create mechanisms providing structural integrity. The biological cell membrane is the film. Even local breakage of the membrane can cause the cell death. The Earth crust is the membrane through which the energy comes to the planet from the space and the excess energy in the form of catastrophes, volcano eruptions, hurricanes and storms is discharged. The average depth of the Earth crust is 35 km with the Earth radius being of 6370 km. Fortunately, we are unable to “make a hole” in it now. The ionosphere is the unique film separating us from the space and solar radiation. There are some active attempts to destroy it now. The attempts are in the layer of maximum 100 km.

Before the explosion of the first nuclear bomb there was a question whether it would be a match that would initiate the chain reaction of oxygen and hydrogen that would cause the atmosphere burning. Fortunately, the “match” was too small. .

V.I. Vernadski said: “The space radiation coming from all spheres covers the biosphere, penetrates into it turning it into the area of space energy transformation” /12/. The biosphere is included into the wider hypersystem of the Earth with the united interaction of the earth and space processes. The biosphere organization is the function of not only of the Earth hypersystem but also of the space. Thus it is the function of the planet and space organization. Finally, according to the ancient knowledge tradition, the matter is in the control of the process of interaction of the Sky and the Earth /7/.

### **Conclusions:**

1) We should work with the heritage of N. Tesla and introduce the results into the peaceful energy.

2) We should work at ecologically friendly getting of energy and implementation of the dream of N. Tesla to create the free system of energy supply to the entire Earth. We can start with a city, a region, or a country.

3) As the task is interdisciplinary the results of the research are to be reported at the conferences and supported through the Internet. According to the Yandex search engine more than 6.5 000 Russian language resources that discuss the ideas of Tesla. There are 71 000 of the English language resources according to the Google.com.

4) The versions of understanding and development of N. Tesla's ideas are given in the paper.

### References:

1. G.G. Malinetski. Risk Control. Risk. Sustainable Development. Synergy. - <http://risk.keldysh.ru/risk/titul.htm>
2. Y. Khramov. Physicists. Biographical Reference Book.- M.: Nauka, 1983. <http://physics.5ballov.ru/Biograf/tesla.htm>
3. A. Abramovich. Metaphysics and Cosmology of the Researcher N. Tesla // Delphis, №4(20), 1999.  
[http://roerich.com/delfis/delphis\\_1999\\_4\(20\).djvu](http://roerich.com/delfis/delphis_1999_4(20).djvu)
4. Y.V. Mazurin. Nikola Tesla – a Slavic Genius // Delphis, №1(17), 1999.  
[http://roerich.com/delfis/delphis\\_1999\\_1\(17\).djvu](http://roerich.com/delfis/delphis_1999_1(17).djvu)  
<http://www.roerich.com/zip/tesla.zip>
5. N.S. Lidorenko. Scientific and Technical Foundations of Power Engineering of the XXI Century. RAS Newsletter, “Energetika” №2, Moscow 2003, №1 Moscow 2005.
6. N.S. Lidorenko. The Doctrine. “Is it the Second Revolution in Power Engineering?” Preprint “Elquant” 2004.
7. N.S. Lidorenko. Mysteries of Nikola Tesla. <http://www.h-cosmos.ru/papers/l001.htm>
8. V.I. Kuzmin, N.A. Galusha. Nikola Tesla and Power Engineering of the Future // Delphis, №2 (46), 2006.  
[http://roerich.com/delfis/delphis\\_2006\\_2\(46\).djvu](http://roerich.com/delfis/delphis_2006_2(46).djvu)
9. S. Akasofu. Polar and Magnetospheric Substorms. M., Mir, 1971.
10. V. I. Kuzmin. N.A. Galusha. Dominating Linear Sizes in Natural and Man-made Systems // Information Measuring and Controlling Systems №3 (4), 2004. P. 3.
11. Physical Encyclopedia. M., Sov. Enc., 1990.
12. M. Pukhovskaya. Secret Reports of the Pentagon with the Earth Ionosphere Can cause Chaos / Novi Mir December 2004. p. 46.
13. V. I. Vernadski. Chemical Structure of the Earth and its Surroundings. M., Nauka, 1987.

## Chapter 3. Energy of the future

### 3.1. The World Outlook Characteristics of the Paradigm Change in Energy

A.V. Levshov, S.G. Dzhura, V.I. Chursinov, V.V. Yakimishina

Donetsk National Technical University

*A new concept of metapower engineering is introduced in the paper. Its background and the ways of getting are given. A number of interdisciplinary tasks as to overcoming of the energy crisis are solved. The concept of a new substance particle- Teslion- which can be the basis of the new world outlook is proposed. The appropriateness of the task formulation is proved. .*

*Key-words: science paradigm, science syntagma, energy crisis, interdisciplinary task, ethic algorithm, Teslion, nanotechnology.*

Introduction into the problem: The mankind spent as much minerals during last 30 years as it did during the entire history of its existence (according to the latest data /1/). That is why it is extremely important to find the way out of the current energy crisis. The current science is experiencing the revolutionary transition described and prognosticated by T. Kuhn /2/. The paper authors have proposed the energy development vector several times /3-7/. The theory is developed in the paper, which is an attempt to share experience and grounded view of the future of pedagogic from the perspective of reconsideration of power engineering discipline teaching.

Through the concept of scientific revolutions to a new syntagma

According to T. Kuhn /2/ introduction of the paradigm concept is the key concept of the structure of scientific revolutions that makes it possible to describe the periods. The paradigm is a system of fundamental knowledge and activity patterns directing research and recognized by the scientific society. According to T. Khun the concept of paradigm involves not only methodological and epistemic characteristics of the scientific knowledge growth into the analysis of science historic dynamics. It also

takes into account social aspects of the scientific activity expressed in functioning of scientific communities. The scientific community is characterized as a group of scientists having the necessary professional training and sharing the paradigm which is a system of fundamental concepts, principles, patterns and norms of research activity.

The paradigm change means a scientific revolution. It introduces the new paradigm and organizes the scientific community in a new way. A part of scientists goes on defending the old paradigm, but many of them are united around the new one. If the new paradigm ensures success of discoveries, accumulation of new facts and creation of new theoretical models explaining the facts, it wins more and more supporters. As a result, the scientific community that survived the revolution enters the development period which T. Khun called the normal science /2/.

Published works of the American researcher of Japanese origin Michio Kaku /8/ and his predictions for 100 years are rather interesting and match the concept of metaknowledge studying of which is the main task of the Institute of Culture of DonNTU. The energy problem in the search version of the metascience has been discussed here not once /9, 10/. It is the testing area of ideas that can be put forward and discussed.

**The problem pedagogic aspect.** Michio Kaku compares the eastern and western education systems and describes the practice of Singapore: “The school marks got by Asian schoolchildren are much higher than those got by their western contemporaries. But their knowledge is a result of cramming that can lead to some level in science and technology. To reach a higher level a person needs to have creative abilities and developed imagination, and inventiveness that the eastern education system does not develop at all. China will be able to catch up with the West as to manufacturing of cheap and mass products, which are replicas of the western ones, one day. But it will lag behind as to the creativity, the ability to design new products and develop new strategies during several decades” /8/. The operation of the Institute of Culture of DonNTU is aimed at it as the outstanding scientists of the present deliver their lectures here /11/.

**The paradigm change.** Changing of the world outlook postulates that are the foundation of any science is always a dramatic thing. Metaknowledge says: “The innovator’s crown is that of thorns”. That is if a scientist improves something a little, he will get a degree etc. But if he



found some cardinally new solution for the problem, he might be a pariah and even pay for it with his life. Nikola Tesla will always be an example of it. We have some unknown in Ukraine materials and are happy to share them. We was not he allowed to finish his project of free (!) and non-fuel (!) system of energy supply to the Earth planet? The answer is very clear: what should we do with the energy which is working now and into which billions of currency were invested? Sometimes it is better to get rid of the innovator (sometimes even in the physical sense). Unfortunately, it is the fact. The innovator wants to do much good to the mankind and expects that it will be grateful and accept such a present. But /12/ says: “The science of Russia is a complete destruction”. However the plan can grow even in the asphalt. Here are some latest examples. There has been a conference “Artificial Intelligence: Philosophy, Methodology, Innovations” in Moscow quite recently /13/. The presentation of Prof. Yasnitski from Perm “Neural Network Technologies as a Method of Getting of New Knowledge” was actively discussed at the round table meeting. He summarized Perm’s practice of creation and application of intellectual systems in industry, economics, sociology, criminalistics, political science, ecology and medicine. The neural networks are known to have discovered new scientific and engineering knowledge that provided higher accuracy in diagnostics, forecast and optimization of the modeled phenomena and processes. The presenter emphasized that some of the knowledge had been recognized by the scientific community (for example the project E-Aesculapius in medicine). Some of new regularities were given materialistic explanations only after long discussions with experts. Some of them still can’t be explained in the frameworks of the traditional scientific theories. The reporter was given are recommendation “not to mix the official science and esoteric”. However, the majority of the speakers agreed that “the modern scientific world had become less orthodox” and new knowledge and facts even if they did not fit into the frameworks of generally accepted knowledge must be published as a “discussion subject matter” as their application for the development and implementation of the intellectual systems helped get more significant results. There was a slogan at the conference: “We ask you not to take our results seriously as astrology is in the black list in the fight with the pseudo-science made up by the Presidium of the RAS”.

The second example is a report on N. Tesla's technologies. Prof. D.S. Skrebkov, the Director of the Research Institute of Agriculture Electrification is N. Tesla's follower. It was his institute that introduced and made devices based on Tesla's technologies changing energy ideas of the century. They have been patented. His presentation at the congress «Global Future 2045» is in /14/. Prof. E. Kurenni working at DonNTU /11/ confirmed he had seen the devices operating despite the fact that they must not operate according to the current energy paradigm. But they do operate! We mean a hair-thin wire through which the spotlights with huge load are connected. According to the theory the wire is to burn out. But it operates! It's absolutely different vision of energy. We think our collaboration with the institute is in perspective. Unfortunately, the words of Prof. Skrebkov are not heard at the highest level. Energy is developing in its usual way. Some European representatives try to buy Prof. Skrebkov's products to organize their manufacturing abroad and sell them to the CIN countries and around the world (as it was with 3-D technologies, and the first European computer created in Kiev), the mobile connection, CD/DVD etc.) Will we be tolerant to the situation further on?

Prof. Skrebkov says that we teach yesterday's power engineering at universities. It is last century. We do not teach anything new, although we should give our students the knowledge they can apply when the graduate. To do this we need to have the new knowledge ourselves. Unfortunately, not very many academics want just discuss the subject matter as we have only half-filled assembly hall during the meetings of the Institute of Culture of DonNTU though many people from different countries of the world watch the video channel. Well, the Bible says /15/: "Jesus told them: no man is a prophet in his own country."

The administration of DonNTU initiated construction of a church on the territory of the university. It is a sign of time changes. One of the meetings of the Institute of Culture of DonNTU was devoted to the book "The Proof of God's Existence: Arguments of a Scientist"/16/. Its author is the head of the team that decoded the human genome. He says: "The deeper science is the closer to God we are" /16/.

Prof. Skrebkov made his speech at the presentation of the book about N. Tesla /18/. It took place at the House of Journalists because according to the professor the participants will appear in front of journalists immediately

after it is over (as N.Tesla always did) for them not to hide the discoveries and put them on a shelf. It is different physics (N. Tesla used the air physics which is not mentioned at universities. Neither is string theory physics which is 11-D). Actually, he worked in the multidimensional space without any computer and solved the tasks using his brain. To do it he developed his own method which is not taught at universities either. The meetings of the University of Culture of DonNTU emphasize it, but who cares...Again “no man is a prophet in his own country”.

One of the book chapters called “From the Bible to Tesla” says: It is at present that we started understanding that a thought, consciousness and mind have their own energy that can be very useful. The development of a new technology is expected. It is going to be based on non-local characteristics of the consciousness which is the fifth and the highest measurements and thought power.... The consciousness technologies are the peak achievement of the progress about which **N. Tesla says the following: “Despite it is the future source of the initial energy we are to get it without usage of any material” /18/**. It completely correlates with the ideas covered by the speech of the Rector of DonNTU Prof. Minaev in front of Master’s students he has made this year: “You can use computers perfectly. You are aces in the technologies. But can you use your consciousness and sub-consciousness? It is the question”. As long as the western science develops visual things and not the human being himself, he will be a mystery for the science. The oriental science develops the inner human being. It is only N. Tesla that was able to combine it in the energy. The book /19/ is devoted to him and there are not many heroes that were brave enough to discuss it. Here are some fragments of the presentation that are not present in the book but which were discussed at the conference “Ethics and the Future Science” in Moscow. DonNTU and MHTU named after N. Bauman were the conference co-founders. In author’s opinion the presentation foresees the particle that appears under the transition into the nanorange which is so popular today. The author of the book called it Teslion (see fig.1).

It is true that with the penetration into the microworld the man discovers new particles. Higgs boson – the God’s particle – has been discovered this year. It is the last missing element of elementary particle modern theory which is the so-called standard model that combines all

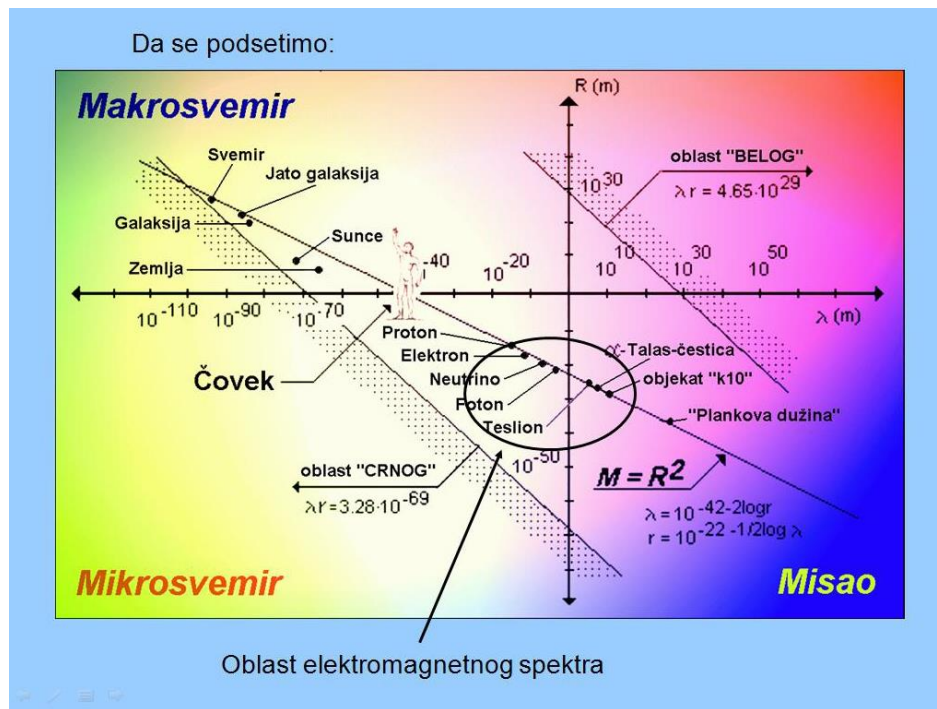

Fig. 1. Teslion in the rank with proton, electron, neutrino and photon.

interaction types except for the gravitation one: strong ( connecting quarks in the protons and neutrons), weak ( interaction between electrons and neutrino) and electromagnetic /20/. If it is really true, it will be the revolution in physics and, for example, the theory of existence of additional space measurements will be proved. It is the most significant experimental discovery for the last 30-40 years /21/.

**Conclusions:** The outlooks of transition of the modern energy into a new paradigm and its reasonability under the lack of interest to it are shown. There is no understanding of who will benefit and thus of any metaknowledge and understanding of metaenergy. The metaenergy level is an absolutely different knowledge level; it is a jump in the mankind's evolution. We think that the scientific and technical revolution is to be substituted by the spiritual one which is going along the world. It is based on distant learning new structures. DonNTU has carried out an education experiment in the area. The interest to the new form of the knowledge transfer is growing /22/. The Institute of Culture of DonNTU fulfills the main function of universities - the cultural one. The words of Socrates are

its slogan: “There is only one good, which is knowledge, and there is only one evil, which is ignorance”.

Fig.2 illustrates N.Tesla’s longitudinal waves:

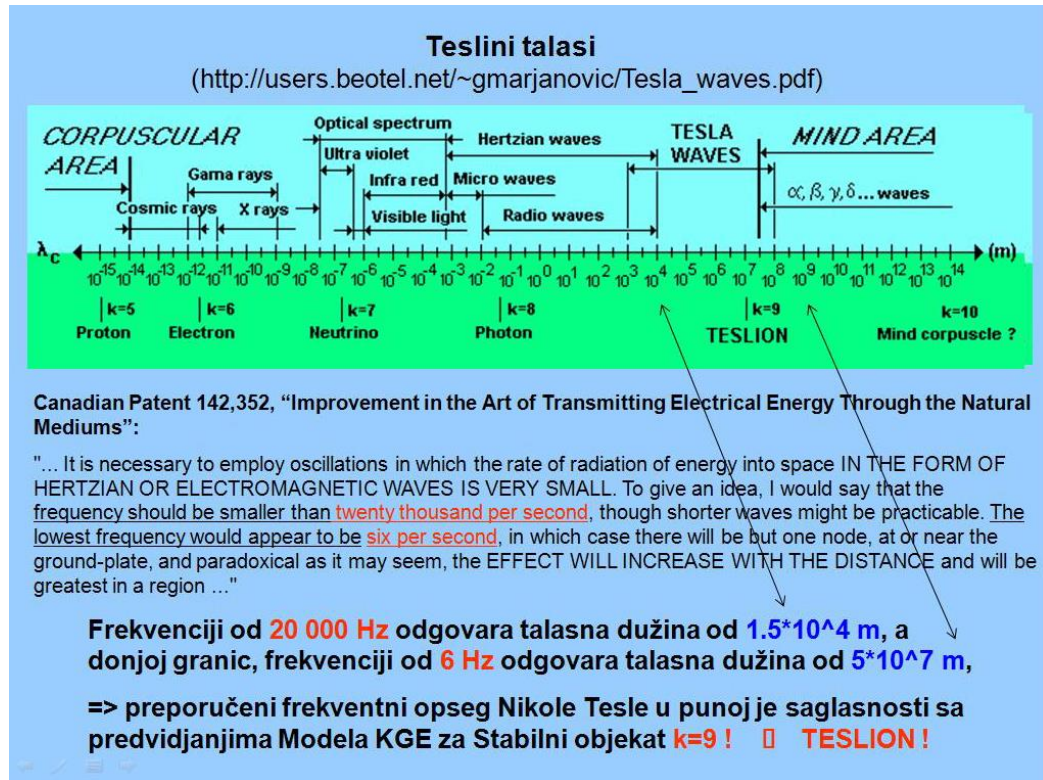

The main task is to transfer the knowledge about which Prof. M. A. Basin from the University of St. Petersburg says: “There is some information not conveying of which to citizens for free is a larger crime than murder and terrorism” /23/. That is why the meetings of the Institute of Culture are free as the main knowledge is got for free (from our parents, the Bible that is presented to us etc.).

The workers of the Institute of Culture of DonNTU have no right to obtain money. The Institute has no diplomas but it gives the knowledge in which life is the examiner. The Institute works in 5 areas: new science fields, the world art masterpieces, the world cinema masterpieces, theatre, and music. They are studied from the point of view of the metaknowledge /24/, which is the culture peak that includes Agni Yoga, theosophy and the Temple of the People. In 2014 the Institute of Culture of DonNTU celebrated its 7<sup>th</sup> anniversary that is why a newcomer is to get himself acquainted with distant courses (audio lectures and the library awarded by the Diploma of the World Club of the Residents of St. Petersburg in 2008).

## References:

1. V.G. Rodionov. Energy: Present Problems and Future Possibilities. – M.: ENAC, 2010. – 352 p.
2. T. Kun. Scientific Revolution Structures. M.: progress, 1977. – 300 p.
3. A.V. Levshov, A. P. Kovalev, S.G. Dzhura. On the Way to the Clue of N.Tesla's Phenomenon (Interdisciplinary Approach) // Proceedings of Donetsk National Technical University. Series "Electrical Engineering and Energy", issue 7 (128). - Donetsk: DonNTU, 2007. – p. 11-13.
4. A.V. Levshov, S.G. Dzhura, V.I. Chursinov. On the Way to Metaenergy // Proceedings of Donetsk National Technical University. Series "Electrical Engineering and Energy", issue 9 (158). - Donetsk: DonNTU, 2009. – p. 152-155.
5. A.V. Levshov, S.G. Dzhura, V.I. Chursinov. Multidimensional Energy // Proceedings of Donetsk National Technical University. Series "Electrical Engineering and Energy", issue 9 (158). - Donetsk: DonNTU, 2011, – p.108-112.
6. A.V. Levshov, S.G. Dzhura, V.I. Chursinov. Ethic Algorithms of the Universe // Newsletter of the SFU- DonNTU. Proceedings of the 11<sup>th</sup> International Practical Seminar "Practice and Outlooks of Development of Partnership in Higher School". In three books. - Taganrog, SFU. Book 1. 2010, №10. - p. 87-107.
7. A.V. Levshov, S.G. Dzhura, V. I. Chursinov. Outlines of Quantum Energy // Proceedings of Donetsk National Technical University. Series "Electrical Engineering and Energy", issue 12 (12-13). - Donetsk: DonNTU, 2012, – p.159-165.
8. M. Kaku. Physics of the Future. – M.: Alpina Nonfiction, 2012. – 584 p.
9. The Institute of Culture of DonNTU: [http://www.roerich.com/n\\_m\\_.htm](http://www.roerich.com/n_m_.htm)
10. A.V. Levshov. Euphoria, Disappointment and Realities of Green Energy. <http://www.youtube.com/watch?v=UL5MgX1HJ00>
11. E.G. Kurenni. The Future Energy. <http://www.youtube.com/watch?v=YRh9MNclEp0>

12. The site “Murders of Real Russian Scientists”  
<http://www.kramola.info/vesti/metody-genocida/216>
13. The Conference “Artificial Intelligence: Philosophy, methodologies, Innovations”. <http://www.scmaiconf.ru/matireals.php>
14. D.S. Skrebkov. Outlooks of Modern Energy.  
<http://www.youtube.com/watch?v=99zEcK7haWg/>
15. The New Testament, the Word, ch. 13, st. 57.
16. F. Collins. The Proof of the God: Arguments of a Researcher. - M. Alpina Nonfiction, 2008. – 216 p.
17. I.V. Plokhov. Speech at DonNTU.  
<http://www.youtube.com/watch?v=jGT211FT1v4/>
18. S. Vlaici. Nikola Tesla is a Man-Angel. – M.: Delphis, 2013, 212 p.
19. Presentation of the book of S. Vlaici. Nikola Tesla is a Man-Angel.  
<http://www.youtube.com/watch?v=ju3jIa9HW9s&feature=c4-overview&list=UUq9M6JhxotheltRbK9qJ-LQ/>
20. Researchers Declare the Discovery of Higgs Boson.  
[http://www.bbc.co.uk/ukrainian/ukraine\\_in\\_russian/2012/07/120704\\_ru\\_s\\_higgs\\_boson\\_discovery.shtml](http://www.bbc.co.uk/ukrainian/ukraine_in_russian/2012/07/120704_ru_s_higgs_boson_discovery.shtml)
21. God’s Particle Exists: Physicists Officially Informed on Discovery of Higgs Boson. <http://techno.bigmir.net/discovery/1521536-Chastica-boga-sucshestvuet--fiziki-oficial-no-ob-javili-ob-otkrytii-bozona-Higgsa>
22. Portal Oriflamma.: <http://roerich.com/>
23. M.A. Basin. The Road to the Synergonet. – St.Pb.: Norma, 2004. – 148 p.
24. L.M. Gindilis. Scientific and Metascientific Knowledge. – M.: Delphis, 2012. – 576 p.
25. A.L. Zelmanov. About the Infinity of the Material World // Dialectics in the Science of the Inanimate Nature. M.: Mysl, 1964. p. 227-269.
26. A.L. Zelmanov. The Variety of the Material World and the Universe Infinity // the Infinity and the Universe. M.: Mysl, 1969. p. 274-324.
27. L.M. Gindilis, N.L. Gindilis. Knowledge Evolution and Synthesis// Delphis, №1 (73)/2013. p. 59-67.

### **3.2. Heading to N.Tesla's phenomenon solution (interdisciplinary approach)**

A.V. Levshov, A. P. Kovalev, S.G. Dzhura

*The review of the materials devoted to the mystery of the great electrician N. Tesla is made in the paper. N. Tesla's methodology and the universe conception as well as versions of the mystery solution (the Philadelphia experiment, the radio echo) are examined. The ways of creation of pure energy are outlined.*

N.Tesla's 150<sup>th</sup> anniversary was celebrated in 2006. The paper devoted to the event and published in the proceedings of the Electrical Engineering Faculty of DonNTU /1/ was paid attention to. Besides, the researchers of the Faculty collaborate with their foreign colleagues. The paper is a result of the collaboration of researchers of DonNTU, MHTU named after N.E. Bauman, the Institute of Mathematics of the Russian Academy of Science named after Keldysh. It is a review, but the subject-matter of the paper is so wide, that its solving would be of great significance for the mankind. N. Tesla left many mysteries as, to his opinion, their solutions passed to the modern mankind that is a civilized barbarian in the main, could lead to unpredictable results for the world /2/. Which of the projects started by N. Tesla were not implemented? They are, first of all, ecologically friendly energy sources on the space scale; creation of the ecologically friendly world energy supply and getting of the space energy; energy transfer without energy loss. If the tasks had been solved Tesla's name would be immortal. He could not finish the projects because of some circumstances as huge investments were necessary. But the fact of the task existence and beginning of the engineering construction mean much (the experimental part of the projects was successful). The experiment results are still agitating minds of researchers /3-7/.

The tasks that are mentioned above can not be solved in the frameworks of one science. According to Gödel's theorem there always are problems in any science that need the results achieved by other ones, such



as mathematics, physics, philosophy etc. If the tendency of solving the tasks is found, it is great progress.

N.Tesla's methodology. According to ancient philosophy it is not obligatory to follow thinkers of the past. We should just see in the same direction. Methodology is the first and amazing fact. N. Tesla did not use mathematical models and computer modeling. He made all his calculations in his head as he "saw their solutions". More than that, he said he was not the author of the inventions on which the power engineering of the XX century is based. He wanted to say that the solution had been given to him from above. We speak about the most mixed phenomenon of religious, occult and mystic life. It is the phenomenon of taking information (messages, recommendations, instructions) coming from an invisible source that a receiver takes in different ways – as own sub-consciousness, the highest "I", bodiless spirits (dark and fair) and gods (right up to the Unique Creator and the Pantocrator). Thus the phenomenon is explained according to the world outlook and abilities of man, his contact and the contents of the revelations he gets. Prof. Puck calls the source "the space database" or the God /8/. It is true that "little knowledge leads away from the God, and great knowledge leads to Him". The words of a famous mathematician Weyl about scientists that achieved their peak in tortures and were surprised to see theologians sitting there in comfort prove it. The clue to the task is in the information theory according to which "A word was at first". Prof. Puck spoke about it in his numerous speeches and the book "A Researcher and a Healer about Clear Force and Devilry" which the professor devoted to his wife who does not believe in any devilry /9/. The subject matter is an open-ended question for the present scientific paradigm. However, according to Kuhn's theory of scientific revolutions the coming scientific paradigm is to explain the facts that the current one fails to do. N. Tesla seems to have the answers. The book written by one of N.Tesla's associates whom the latter trusted very much proves it /10/. The preface says /11/: "Tesla stepped 100 years forward and provoked the most important (and as the time showed the bloodiest) technical revolution. He thought he was working for the good and invented the induction motor, the daylight lamp, the wireless communications, the remote control shells, the ladar guns and the vertical take-off aircraft. He was such a powerful man that he is thought to put his hand to Tunguska meteorite falling. N.Tesla

was sure x-ray must be used in medicine only while he was able to break the Earth planet with the help of resonance...

Who knows what our world would be like if N.Tesla had implemented at least a half of his grand projects? Who knows whether our world would exist at all...?"

**N.Tesla's concept of the Universe** The base for N.Tesla's invention was alternative physics, i.e. the physics that includes the universal air. According to his concept electricity is not an integral substance and, of course, is not an electron motion only. N. Tesla showed that the electricity could be split into the fractions of the Heat and Light Air. When this takes place the Light Air rushes under the right angle leaving the Heat Air behind and extracts a great amount of energy from the environment. The modern researchers are sure that thermodynamic laws and Maxwell's equations can not be applied to aerial technologies without being improved and thus do not describe all possible actual things achieved by electric science. In N.Tesla's opinion the nature of electromagnetism is a very original one. Thus, according to him, electromagnetic waves are transverse-longitudinal air vibrations. The common energy of one physical system is defined by the laws of vibration resonance and system part vibration coincidence. This is the initial axiom of his theory. The time is a real algorithm of materialized mathematics and it is created out of the air due to the physical system resonance and comes back to the air. He made crucial conclusions: the substance consists of organized parts which are the demonstration of the air excited state, electromagnetic vibrations being one of it. That is why the resonance law is the general nature law. The phenomena are connected by different resonance types based on electromagnetism.

Tesla's non-fuel generator operation is based on work element rotation relative to the null point. The generator has a rotor that spins in the variable magnetic field with some degree of freedom similar to the gyroscope. In some time the rotor self-centers in the space and its rotation becomes synchronous with the rotation of the current Universe relative to the null point. After that the process goes with the highest probability and it is accompanied by the growth of the inner energy, that is, the rotor moves along its most probable trajectory in the world event space. The change of the ratio between the generator inner energy and its own time rate causes the gravitation weight reduction. According to Tesla's concept the time

passed on the planet is defined by the sphere rotation relative to the null point, that is, by the rotation phase relative to the rotation start. The latter means the moment of transition of the world torus from the state of expansion to that of compression. As the cycles are endless the universe does not have either beginning or end, that is, the Universe is eternal /12/.

**Philadelphia Experiment.** In 1940s Nikola Tesla, A. Einstein and R. Oppenheimer were involved in a secret project supposedly aimed at creation of invisibility of the ships of the USA Navy. John von Neumann was sure to take part in it too. They were working at creation of the magnetic field of super intensity based on Tesla's vertical generator. The results of the experiments carried out on the specially equipped destroyer Eldridge were immediately classified as secret that itself says about their extreme importance. There are a lot of sites in the Internet devoted to the experiment but there are no particular information and recognized facts. There are reasons to think that the Philadelphia experiment was aimed at instrumental test of the universe diversity and creation of the probable tunnel to the future based on the unique chronotechnology. Besides, the connection between N.Tesla's disappearance and the beginning of the Philadelphia experiment remains unknown.

The spheroidal vortex field of the modified air ("the time cloud") was created around the ship with the help of the resonance generators and as a result the induced change of the ship and crew vibration frequency took place. The green elastic substance which is the result of the modified air pulse appeared in the oscillator operation field. The ship got into other versions of the Earth and escaped from the observer sighting. However, as the metal hull was moving its most probable position coincided with the current Earth position for some period of time. Thus, the empty ship was seen in the place of its future mooring in Norfolk.

The description of the experiment might seem fantastic. That is why so many books and films were devoted to the experiment. However, the hypothesis that describes the experiment correctly appeared only nowadays.

A scientist from St. Petersburg N. Yerofeev /12/ has suggested an interesting scientific hypothesis about the alternative realities being the version of V.I. Vernadski's noosphere motions (philosophical interdisciplinary conferences are held at DonNTU very often). According to the

hypothesis there are the so-called T-reality (which we usually take as the reality) and the A-reality (the alternative or virtual reality). The A-reality has its phase shift relative to the T-reality and to the null point – the Universe rotation centre. It causes the fact that the A-reality substance has a different frequency of its own vibrations. That is why, according to N. Yerofeev, the “alternative” substance can not be seen in the T-reality. The similar A-realities are geometrically close to each other but they can not interact materially as the moments of existence of the T-reality fall on the moments of nonexistence of the A-reality. Their information interaction might be possible under the resonance of the coherent mirror twins processes.

N. Tesla’s concept is very important for studying of the A-reality physical aspects as according to the researcher the current material world is an interference (holographic) picture of standing waves under the world air vibration at a certain frequency. Different air vibration frequencies and phase shifts condition the existence of several material worlds the substance of which has its own different vibration frequency.

According to N. Tesla the worlds are spread in the 5-D universe with the phase shift in accordance with the octave law. Space and time intervals among the realities must be geometrically connected in accordance with the golden ratio. Philosophical doctrines of Anaxagoras, Leucippus and Democritus are the forerunners of N. Tesla’s concept.

**The LDE problem solution.** The world outlook concept of N. Tesla helps solve the famous problem of the radio echo – LDE (Long Delay Echo). Some radio stations got the radio echo of the certain frequency signal which they radiated into the world space. The radio echo was also taken by other radio stations tuned in the given frequency. The signal delay made up from some seconds to a minute. The power attenuation was minor as if the signal was relayed by another transmitter (which in fact did not exist). N. Yerofeev explains it by the resonance in the world air. There are some other explanations which, in our opinion, are probable: the radio signal reflection from the natural objects or the probe of other planets. These suppositions can not be proved or disproved so far. But we think that the explanation based on N. Tesla’s methodology is the most probable. To explain the LDE phenomenon the ideas of S.B. Pereslegin can be used. Like N. Tesla he shows the necessity of introducing of the fifth

measurement, the movement in which characterizes the development alternative ways. As the reality exists in the world air the chance of the information transfer among their versions is to be taken into account. The so- called time static concept (the past, the present, and the future exist in their versions simultaneously) and N. Kozyrev's time concept are used.

### **Conclusions:**

1) N. Tesla's work forces reviewing the current scientific paradigm and finding the ways of its replacement on the basis of the latest scientific information.

2) In authors' opinion the development of the world energy system based on the ecologically friendly ideas of not only hydrogen energy but principally new sources the ways to which were shown by N. Tesla is very promising.

3) The scientific community is facing not just the paradigm change but the change of their hierarchically most significant state which is the science syntagma.

4) The understanding and versions of development of the ideas of N. Tesla are proposed in the paper.

### **References:**

1. A.P. Kovalev, S.G. Dzhura, L. V. Chernikova. Energy Risk Control (to the 150<sup>th</sup> anniversary of Nikola Tesla) // proceedings of Donetsk National Technical University. Series: "Electrical Engineering and Energy", issue 112. Donetsk: DonNTU, 2006. – 151-153.
2. A. Abramovich. Metaphysics and Cosmology of the Researcher N. Tesla //Delphis, №4 (20), 1999. [http://roerich.com/delfis/delphis\\_1999\\_4\(20\).djvu](http://roerich.com/delfis/delphis_1999_4(20).djvu)
3. Y. V. Mazurin. Nikola Tesla – a Slavic Genius // Delphis, №1(17), 1999. [http://roerich.com/delfis/delphis\\_1999\\_1\(17\).djvu](http://roerich.com/delfis/delphis_1999_1(17).djvu); <http://www.roerich.com/zip/tesla.zip>
4. V. I. Kuzmin, N. A. Galusha. N. Tesla and the Future Energy // Delphis, №2(46), 2006. [http://roerich.com/delfis/delphis\\_2006\\_2\(46\).djvu](http://roerich.com/delfis/delphis_2006_2(46).djvu)

5. N.S. Lidorenko. Scientific and Technological Foundation of Ecological Energy of the XXI Century. Newsletter of the RAS, "Energy" №2, Moscow 2003, №1 Moscow 2005.
6. N.S. Sidorenko. The Doctrine "Is it the Second Revolution in Energy?" Preprint, Elquant, 2004.
7. N.S. Lidorenko. Nikola Tesla's Mysteries. <http://www.h-cosmos.ru/papers/1001.htm>
8. V.V. Puck. An Engineer, Mathematics and Others: Simple Methods of Mathematical Modeling of Natural and Anthropogenic Processes/ Donetsk State Technical University. Donetsk, 1995. – 224 p.
9. V. V. Puck. About Physical Nature of the Clear Force and the Devilry. – Donetsk: Stalker, 1999. [http://www.roerich.com/zip2/pak\\_sila.zip](http://www.roerich.com/zip2/pak_sila.zip)  
[http://www.roerich.com/zip3/tesla\\_ao.zip](http://www.roerich.com/zip3/tesla_ao.zip)
10. D.D. O'Nil. The Overflowing Genius. The Life of N. Tesla. – M.: Sattva, 2006. [http://www.roerich.com/zip3/tesla\\_1.zip](http://www.roerich.com/zip3/tesla_1.zip)
11. M. Safer. America's Absolute Weapon. – M.: Eksmo, Yauza, 2005.
12. N. Erofeev. Signals from the Alternative Realities //Delphis, №1(49), 2007. [http://roerich.com/delfis/delphis\\_2007\\_1\(49\).djvu](http://roerich.com/delfis/delphis_2007_1(49).djvu)

### 3.3. Introduction to metaenergy

A. V. Levshov, S.G. Dzhura, V.I. Chursinov  
"Donetsk National Technical University"

*A new concept of metaenergy is introduced in the paper and its backgrounds as well as way of the concept understanding are given. A number of interdisciplinary tasks of finding the way out of the energy crisis are solved. The concept of the metaenergy is proposed through the multidimensional reality concept. Appropriateness of the task is proved.*

*Metaenergy, energy crisis, interdisciplinary task, ethic algorithm, superposition of point-localized states.*

**Introduction to the problem.** Energy crisis is one of the main problems of the modern civilization. The civilization is using more and more resources and needs more and more energy, however its traditional

sources are limited. Inexhaustible source of energy (solar, wind, tide, bioinstallations etc) can cover at maximum 10% of demands of the modern civilization. The situation forces to look for new ways of the problem solving. The authors have made some contribution to it /1-5/.

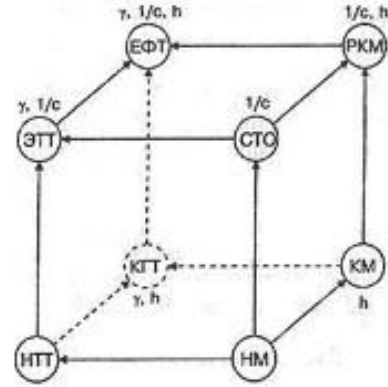

Fig. 1. «Zelmanov's cube».

The analysis of the world physical picture. Fundamental physical theories make up the core of the physical paradigm. They are characterized by the logic completeness and inherent consistency.

Because of it the fundamental theories /6/ are not given up though new theories and related to them ideas appear in the course of the science development. They remain valid; the sphere of their application is limited.

These fundamental theories act in the sphere of their application. Other, more common theories having wider sphere of application act behind it. Due to it, there is continuity in science. We always come across change of ideas and the world physical pictures, but it does not mean that some knowledge is just replaced by another one. The knowledge is extended as the core of the previous paradigm is included into a new one and everything which is false is given up.

The famous Soviet cosmologist A.L. Zelmanov (1913-1987) marks out six fundamental theories /7-8/: Newton mechanics (NM), Newton gravitational theory (NGT), special theory of relativity (STR), general theory of relativity (GTR) or Einstein gravitation theory (EGT), quantum mechanics (QM) and relativistic quantum mechanics (RQM). What correlation are they in?

Zelmanov's classification is based on Newton mechanics (NM). It is true under the description of the body that moves at the speed that is small as compared with the light speed and is not applied to either gravitation or quantum phenomena.

Newton gravitation theory can be considered Newton mechanics generalization and its expansion to the sphere of the gravitation phenomena. NGT equations are reduced to to NM equations under the gravitation absence.

NM is not applied at the speed close to that of light. It is the sphere of special theory of relativity. It also does not cover the gravitation phenomena. We can say that the special theory of relativity is generalization of Newton mechanics in case when the speed of body movement is close to that of light. If the movement speed is much smaller than the speed of light the equations of STR are transferred to the equations of Newton mechanics. It allows considering it the special case of the STR and the latter as the more general theory that includes NM.

Thus, the three fundamental theories – NGT, STR and KM are direct generalization of NM. This correlation is marked by arrows in the figure. Each of the theories NGT, STR and QM is characterized by one world constant. For the Newton gravitation theory it is the gravitation constant  $\gamma$ , for the special theory of relativity it is the speed of light  $s$  (or the value which is reciprocal to it  $1/s$ ) and for the quantum mechanics it is Planck constant  $h$ . Newton mechanics does not include the world constants. If the corresponding constants  $\gamma$ ,  $1/c$ ,  $h$  of the equations of NGT, SRT and QM are equal to zero, these equations are transferred to the equations of Newton mechanics. It is the mathematical expression of the fact that more general theories of NGT, SRT and QM include NM as their special extreme cases. The sphere of its application is specified at the same time. Newton mechanics is true when the gravitation forces are absent (or are of negligible quantity compared with other acting forces) when the speeds are small compared with the speed of light and the values having action dimension are big compared with  $h$ . /6/.

**The problem historical viewpoint.** Electric and magnetic phenomena known since time immemorial used to be thought about as absolutely independent. Then a close interconnection between them was stated: electric charge movement causes the magnetic field and the magnetic field change creates the electric current. This led to creation of the synthetic theory of electromagnetic field in which the electric and magnetic phenomena are combined into one electromagnetic impact. Later on the special theory of relativity reduced such different categories as the space and the time to one main point – 4D space and time continuum. The next step was an effort to unite the main physical interactions – electromagnetic, weak, and strong and gravitation into the theory of the single universal physical interaction. T. Kaluz and O. Klein made the first



step towards it in the 20s of the last century. They tried to combine the gravitation theory with electromagnetism. They failed to do it but made an important conclusion as to exceeding the bounds of the 3D world. Einstein is known to have dreamt about the theory in which all nature forces are combined. The rest of his life remained after the creation of his theory of relativity he spent working at creation of the theory. However he was not a success either. The task was solved after his death. First the theory of electromagnetic and weak interactions was combined into one general theory of the electric weak interaction. Then it was combined with the theory of the strong interaction. Physicists called this synthetic theory the Grand Unified Theory. In the long run the theory of super unification that integrates all types of the physical interactions into one universal interaction was created (it is not finished yet). There are some approaches to the theory creation. The superstring theory is the most successful one. According to it the fundamental objects of the physical substance are not point particles (as it has been always thought) but tiny one dimensional threads-strings in the form of the closed loop of the size of 10<sup>-33</sup> cm (Planck length). All observed characteristics of the elementary particles (mass, charges etc.) are the demonstration of different types of the string vibrations /9/.

The Grand Unifired Theory is connected with the introduction of additional space dimensions /5/. This multidimensional space is to be filled by some unknown to the modern science substance forms. As Agni Yoga subtle worlds are also connected with other space dimensions we can suppose that the world in front of us is the world of subtle energy of Agni Yoga. Thus, the single physical theory opens the door to the subtle world. The new science and new physics will study the subtle world and, in some time, will penetrate into the Fiery World /9/.

**Science state changes.** The modern science changes its states, which is the normal phenomenon described in Kuhn's theory of scientific revolutions /6/. The discovery of the "God's particle" or Higgs boson is a scientific sensation of the year. It is the cornerstone of the standard model that gives the most complete description of the Universe structure /7/. However, the majority of the researchers think that the standard model is just a stage on the way to the other more complicated theory which is able to explain such phenomena as dark substance and dark energy. Fig. 2

shows the share of different types of substance in the Universe (according to “The Earth and the Universe” №5, 2006).

The visible matter observed by physical devices and consisting of the usual substance makes up approximately 1% of all the matter of the physical Universe. It involves the complete periodic table. 3 more % is a usual substance which consists of atoms or known elementary particles which are not registered by any devices. This invisible matter (or hidden mass) can be discovered only by the gravitation influence it makes on the visible and registered matter. Thus, the usual or baryon substance makes up only 4% of the matter of the Universe. The rest 96 % fall to the so-called dark substance (24-25%) and the dark energy or cosmological vacuum (71-72%) (See fig.2). The origin of this invisible matter is not absolutely clear. The dark substance is said to consist of very massive and weakly interacting particles. But the particles have not been discovered yet and the subject-matter of the substance origin is an opened question. Higgs boson was discovered in summer 2012. Dr. Tara Shears from the University of Liverpool says: “We will see how often it breaks up into Z-bosons and W-bosons. It can fit in with the standard model, but if there are some deviations it will mean that some new physics operates. It will be the first time we will be able to look through the window and see what is behind our understanding”. /12/.

Higgs boson is the final lacking element of the modern theory of elementary particle of the so-called standard model that unites all interaction types except the gravitation – strong (connecting quarks in protons and neutrons), the weak (the interaction between electrons and neutrino) and electromagnetic one /12/. If it is true, it will be the revolution in physics. The theory of existence of additional space dimensions will be proved in this case. This is the most significant experimental discovery for the last 30-40 years /12/.

**Progress conclusions.** Thus, we see the boundaries of our ignorance as every researcher knows the limits of his competence. The universal interaction is a single synthetic beginning only under particle huge energy or extremely high temperatures. The conditions were at the earliest stages of the Universe appearance. The United interaction was true then.

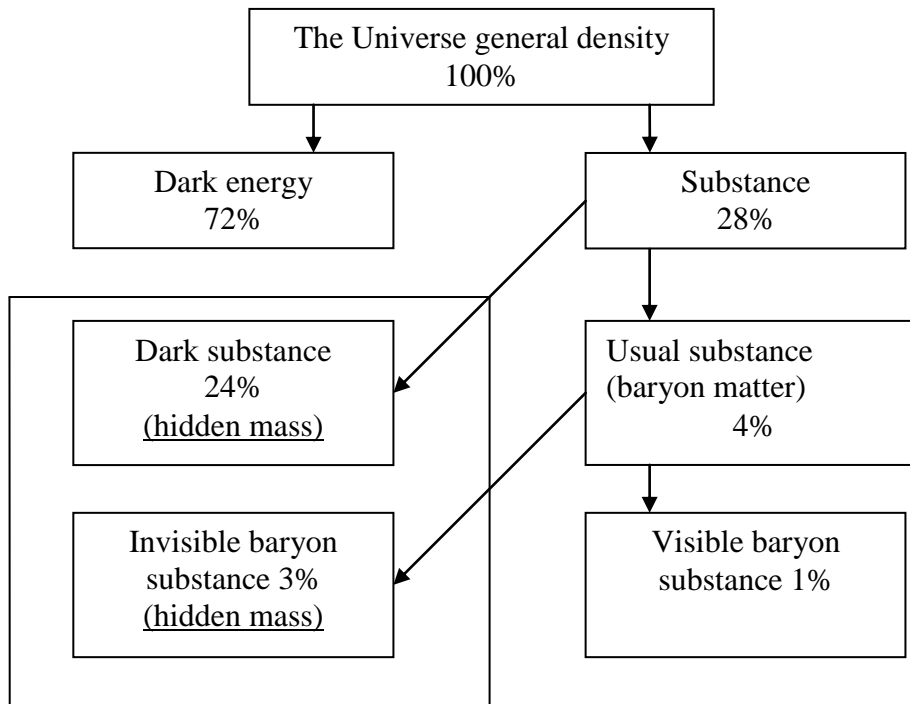

Fig.2. Share of different matter types in the Universe  
(«The Earth and the Universe» №5, 2006).

While the Universe was expanding and the temperature was falling its breaking up was taking place. First it split into the gravitation one and the interaction of Grand Unification. Then the strong interaction left it and in the long run the electrical weak interaction broke into the weak and electromagnetic one. Since then all four interactions are absolutely different forces though they are the demonstration of the single universal force.

The string theory is not finished yet /13/. Some experts think that it will need some decades to finish it or it might take the time till the end of the XXI century /9/.

In the paper /3/ we showed that there was no technical solution of the problem. More than that, the sources of metaknowledge say that the commercial application of the 4 and 5 level energy is banned. The current energy is operating within 3 and 4 dimensional world picture so far. The technical characteristics might be raised , but ethic algorithms /4/ are to be

implemented first as the energy observes the evolution law , like all the mankind worlds.

Penetration into the nanoworld reconsiders many energy postulates. We understand the energy is quantized, like the space and the time. The paper is the review of the most significant papers on the subject matter. It is very important to find the research trend, even if it is a hypothetic one. DonNTU has been taking an active part at the international conference “Ethic and the Future Science” for many years. Some aspects of the paper were presented at the latest one /14/.

**Theoretical base of metaenergy.** Vernadski’s readings often take place at DonNTU. Besides, the portrait of Vernadski is in the Rector’s office. He was not the only one who made his discoveries in the field of noosphere. E. Leroy (1870-1954), P. de Chardin (1881-1955) were also founders of the modern doctrine of the noosphere. E. Leroy specialized in hyperphysics, De Chardin – in metaphysics, V. Vernadski – in physics. Their works can be illustrated by the vibration table presented by the journal London Electrician. There are the vibrations of the generator of the frequencies of 0, 25, and 50 at the bottom. They pass all known frequencies: electric, infrared, sound etc. Of course the frequencies might be higher. Man takes only small range of frequencies in the visible and sound range and makes his conclusion on his own point of view. Devices make the range a bit wider, but it is not limitless. Our knowledge has limits, our ignorance is limitless. Fig. 6. illustrates it.

Taking into account the fact that the overwhelming share of the matter in the Universe falls to invisible components – the dark substance (the term is quite relative as there is no adequate name for it) the question of the nature of the matter that that can not be seen with the naked eye and observed by any physical device is appropriate. The author of the “Physics of the Impossible” and the “Physics of the Future” M. Kaku who had interviewed 300 Noble Prize winners before he wrote the books said: “As far as the dark energy is concerned, it is one of the greatest non-finished chapters of the modern science /18/. But does the invisible matter about which ancient cosmologists revived by theosophy, Agni Yoga and People’s Temple really exist? Is it the matter that forms the invisible world (or at least part of it) the recognition of which is still the stumbling block of the modern science?

EPHER VIBRATION SPECTRUM

Vibration frequency (vibration per second):	octave	wave type	octave	wave length
28 823 000 000 000 000 000	— 60 —	//////	— 60,1 —	0,00001 МКМ
14 412 000 000 000 000 000		unknown <sup>1</sup>		
7 205 600 000 000 000 000		//////	57,6	0,00006 МКМ
3 602 800 000 000 000 000		(X-rays) <sup>2</sup>	— 56,8 —	0,0001 МКМ
1 801 400 000 000 000 000	— 55 —			
900 720 000 000 000 000			53,8	0,0008 МКМ
450 360 000 000 000 000		//////	— 53,5 —	0,001 МКМ
225 180 000 000 000 000				
112 590 000 000 000 000	— 50 —	unknown <sup>3</sup>	— 50,1 —	0,01 МКМ
56 295 000 000 000 000		//////		
28 147 500 000 000 000			— 46,8 —	0,1 МКМ
14 074 000 000 000 000		//////		
7 036 900 000 000 000			44,6	0,4 МКМ
3 518 400 000 000 000	— 45 —	ultraviolet	57,6	0,8 МКМ
1 759 200 000 000 000		visible <sup>4</sup>	— 43,5 —	1,0 МКМ
879 609 000 000 000				
439 804 000 000 000				
219 902 000 000 000				
109 951 000 000 000				
54 976 000 000 000		infra-red		
27 488 000 000 000	— 40 —	waves <sup>7</sup>	— 40,2 —	10 МКМ
13 744 000 000 000				
6 872 000 000 000				
3 436 000 000 000			— 36,9 —	100 МКМ
1 718 000 000 000			35,2	0,33 ММ
858 990 000 000	— 35 —	//////		
429 500 000 000		unknown <sup>5</sup>	— 33,5 —	1,0 ММ
214 750 000 000		//////	31,6	4 ММ
107 370 000 000				
53 687 000 000	— 30 —		— 30,2 —	1,0 СМ
26 844 000 000				
13 422 000 000				
6 710 800 000				
3 355 400 000			— 26,9 —	10 СМ
1 677 700 000				
838 860 000	— 25 —		— 23,6 —	1 М
419 430 000				
209 720 000				
104 860 000				
52 429 000				
26 214 000	— 20 —		— 20,2 —	10 М
13 107 000				
6 553 600				
3 276 800			— 16,9 —	100 М
1 638 400				
819 200	— 15 —	electric waves <sup>6</sup>	— 13,6 —	1 КМ
409 600				
204 800				
102 400				
51 200				
25 600	— 10 —		— 10,3 —	10 КМ
12 800				
6 400				
3 200			— 6,9 —	100 КМ
1 600				
800	— 5 —		— 3,6 —	1000 КМ
400				
200				
100				
50			— 0,3 —	10000 КМ
25	— 0 —			

Main colour	
Red — 0,68 МКМ	879 609 000 000 000
Orange — 0,63 МКМ	439 804 000 000 000
Yellow — 0,58 МКМ	219 902 000 000 000
Green — 0,53 МКМ	109 951 000 000 000
Blue — 0,48 МКМ	54 976 000 000 000
Dark blue — 0,43 МКМ	27 488 000 000 000
Violet — 0,40 МКМ	13 744 000 000 000

Formulae:	
v — light speed	3 436 000 000 000
v ≈ 309 000 000 м/с	1 718 000 000 000
a — octave number	858 990 000 000
c — frequency initial value	429 500 000 000
25 Hertz in this case	214 750 000 000
	107 370 000 000
f — frequency, Hz	53 687 000 000
l — wave length, м	26 844 000 000
	13 422 000 000
l = v/f = v/(2 <sup>a</sup> c); 2 <sup>a</sup> = f/c	6 710 800 000
a = (lg v — lg c — lg l)/lg 2	3 355 400 000
a = (lg f — lg c)/lg 2	1 677 700 000
lg v = 8,489857	838 860 000
lg 25 = 1,397940	419 430 000
lg 2 = 0,301030	209 720 000
	104 860 000

Wave length	Name
.00006 — .0008 МКМ	X rays <sup>2</sup>
.0008 — .01 МКМ	radiation <sup>3</sup>
.01 — 0.1 МКМ	unknown <sup>4</sup>
0.1 — 0.4 МКМ	ultraviolet <sup>5</sup>
0.4 — 0.8 МКМ	visible spectrum <sup>6</sup>
0.8 МКМ — 1/3 ММ	infra-red waves <sup>7</sup>
1/3 ММ — 4 ММ	unknown <sup>8</sup>
4 ММ — бесконеч.	electric waves <sup>9</sup>

Sources:	
London Electrician, LXVIII-19-504,	51 200
London Electrician, LXXI-14-557-558	25 600
Metallurgical and Chemical Engineering, XII-6-363	12 800
	6 400
	3 200
	1 600

<sup>1</sup> - According to modern division, the sphere of gamma radiation and higher  
<sup>2</sup> - The modern name — X-rays  
<sup>3</sup> - Now ultraviolet distance sphere  
<sup>4</sup> - Visible or light waves  
<sup>5</sup> - At present it is accepted to consider the boundary between radio waves and IK range to be equal to 1mm  
<sup>6</sup> - Modern name — radio waves  
<sup>7</sup> - Modern name — soft X-ray

Fig. 4. Air vibration spectrum.

The current physics came close to the invisible world and stopped in front of it hesitating to make the final step /6/. But it has been already done from the point of view of the modern science (Higgs boson) and the second one, that is, the recognition of the metascience and metapedagogics and their introduction into the scientific circulation. It is not an easy case. The researcher of the process L. M. Gindilis says: “Climbing up to the stony science slope a researcher can reach the crest of the mountain range, into the sphere of metascientific knowledge.

Climbing up to the peak of the narrow mountain range he can deviate to the right and find himself at the science slope again. But he can also deviate to the left and fall down to the abyss of pseudoscience. Thus he has to move on the razor edge between the Scylla of the orthodox science and the Charybdis of the pseudoscience”.

**Conclusions:** Thus we come up to the concept of **metaenergy** that includes:

- evolution energy
- energy-and information energy
- Multidimensional energy.

Understanding of the competence limits is very important for the science. The paper gives the grounds for the metaenergy outlook as the uniting vibration not registered by devices. Thus, a new scientific revolution or the final stage of the scientific revolution marked by the creation of the quantum mechanics is taking place now. Many physicists have worked at joining of the concept of consciousness with quantum mechanics since 1980. Publication of textbooks on metaknowledge makes the scientists create new terminology and correct contours of other integral science to which energy belongs. So, it is a qualitatively new field which the authors named metaenergy, according to the field of its application, appears. We think that the key mechanism of its introduction and application is not technical discoveries but ethic algorithms which the authors described in their previous papers.

#### References:

1. A.V. Levshov, A.P. Kovalev, S.G. Dzhura. Heading to the Revealing of the Phenomenon of N. Tesla (interdisciplinary approach) //

- Proceedings of Donetsk National Technical University. Series: Electrical Engineering and Energy”, issue 7 (128). - Donetsk: DonNTU, 2007. –p.11-13.
2. A.V. Levshov, A.P. Kovalev, S.G. Dzhura. Heading to Metaenergy // Proceedings of Donetsk National Technical University. Series: Electrical Engineering and Energy”, issue 9 (125). - Donetsk: DonNTU, 2009. –p.152-155.
  3. A.V. Levshov, S.G. Dzhura, V.I. Chursinov. Multidimensional Energy // Proceedings of Donetsk National Technical University. Series: Electrical Engineering and Energy”, issue 9 (158). - Donetsk: DonNTU, 2011. –p.108-112.
  4. A.V. Levshov, S.G. Dzhura, V.I. Chursinov. Ethic Algorithms of the Universe // Proceedings of the TTI SFU-DonNTU. Proceedings of the 11<sup>th</sup> International Scientific and Practical Seminar “Practice and Outlook of Partnership Development of High School” in 3 volumes. – Taganrog: TTI SFU. Vol. 1. 2010, №10. - p. 87-107.
  5. A.V. Levshov, S.G. Dzhura, V.I. Chursinov. Contours of Quantum Energy // Proceedings of Donetsk National Technical University. Series: Electrical Engineering and Energy”, issue 12 (12 - 13). - Donetsk: DonNTU, 2012. –p.159-165.
  6. L.M. Gindilis. Scientific and Metascientific Knowledge. – M.: Delphis, 2012. - 576 p.
  7. *A.L. Zelmanov*. About the Endlessness of the Material World // Dialectics in Science about the Inanimate Nature. M.: Mysl, 1964. p. 227-269.
  8. *A.L. Zelmanov*. Variety of the Material World and the Universe Endlessness // Endlessness and the Universe. M.: Mysl, 1969. p. 274-324.
  9. L.M. Gindilis, N.L. Gindilis. Evolution and Knowledge Synthesis //Delphis, №1 (73)/2013. p. 59-67.
  10. Kuhn T.S. The Structure of Scientific Revolutions. Chicago, 1962; M., 1975. <http://www.psylib.ukrweb.net/books/kunts01/index.htm>
  11. Scientists Declare the Creation of Higgs Boson. [http://www.bbc.co.uk/ukrainian/ukraine\\_in\\_russian/2012/07/120704\\_ru\\_s\\_higgs\\_boson\\_discovery.shtml](http://www.bbc.co.uk/ukrainian/ukraine_in_russian/2012/07/120704_ru_s_higgs_boson_discovery.shtml)

12. The God's Particle Exists: Physicists Officially Informed on the Discovery of Higgs Boson.  
<http://techno.bigmir.net/discovery/1521536-Chastica-boga-sucshestvuet--fiziki-oficial-no-ob-javili-ob-otkrytii-bozona-Higgsa>
13. B. Green. The Elegant Universe. Superstrings, Hidden Dimensions and the Search of the Final Theory. - M.: KomKniga, 2007. - 288 p.
14. S.G. Dzhura. The Problem of Multidimensional Consciousness // Proceedings of the 10<sup>th</sup> Interdisciplinary Scientific Conference "Ethic and the Future Science" – Consciousness as the Space Creative Force. - M.: Delphis, 2011. – p. 30-39.
15. B.U. Radionov. Battle with Apophis. // Delphis, №1 (73)/2013. p.68-78.
16. B.U. Radionov. Thought Materialization. // Delphis, №3 (71)/2012. p. 58-64.
17. M. Kaku. Physics of the Impossible. – M.: Non-fiction, 2010. – 457 p.
18. M. Kaku. The Future Physics. – M.: Non-fiction, 2012. – 584 p.

### 3.4. Quantum energy outlines

A.V. Levshov, S.G. Dzhura, V.I. Chursinov

*The paper introduces a new concept of quantum energy, gives backgrounds to it and shows the ways of the concept understanding. A number of interdisciplinary tasks on finding the ways out of the crisis are solved. The quantum energy concept is proposed through ethic algorithm creation and understanding. The task statement appropriateness is proved.*

**Key words:** *quantum energy, energy crisis, interdisciplinary task, ethic algorithm, superposition of point-localized states.*

**Introduction to the problem.** The modern energy develops in known ways (traditional trend improvement, with the so-called non-traditional ones being the traditional ones). They are exhaustible sources, and inexhaustible ones (solar, wind, tidal and bio-installations) can not cover even 10% of the modern civilization demands. The situation makes



us look for the new ways of the problem solving. The authors have already discussed some of them /1-3/.

In the paper 3 we should that there is no the problem technical solution. It is the way to nowhere. Of course, it is possible to raise technical characteristics, but only the ethic algorithms /4/ implementation can cause a jump as energy obeys the evolution law, like all the mankind's worlds.

Entering the nanoworld reconsiders many energy postulates. We understand that the energy, like space and time, can be quantized and we will try to examine the way. The paper reviews the most significant works in the field and does not claim to be true. It is extremely important to find at least the research hypothetic trend. Thus, DonNTU has been taking an active part in the international conference "Ethic and the Future Science", the founders of which, besides DonNTU, are MSTU named after N. Bauman and some universities of Russia. The paper is a result of re-examination of the presentation made at one of these conferences by a famous researcher Prof. M.B. Menski /5/.

The statement of the Noble Prize winner W. Heisenberg can be the epigraph to it "The first sip from the cup of natural science causes atheism, but the God is waiting for us at the bottom of the vessel" /6/. It is true that the leading universities of the world have theological faculties (Harvard /7/, Oxford /8/, Cambridge /9/). That is, the subject-matter is seriously studied abroad. There might be a secret taboo to study the science in the post-Soviet countries. But the situation is changing now. There is a part "Science and Religion are Full Sisters" on the portal "Education: Researched in the World" /10/. The book "They Believed in God: 50 Nobel Prize Winners and Other Outstanding Scientists" /6/ and the book of K. Tsiolkovski "The Scientific Belief Shield" which is called the Gospel according to K. Tsiolkovski prove it.

We will try to define the development trends and review the outlooks coming from the micro world and giving hope to finding the future energy which we call the quantum energy.

**Energy philosophy development stages.** The first stage of the scientific revolution (the beginning of the XX century) was grand because "absolutely new philosophy penetrated into physics instead of the vulgar materialism. The revolution was not over. The feeling of mystery that still exists around quantum mechanics proves it. It is only now when the

mankind is trying to unite quantum mechanics with consciousness that the mystery is retreating and the final stage of the scientific revolution started 100 years ago appears” /5/.

**Energy quantum concept.** It is based on the ‘consciousness’ idea. The journal “Consciousness and the Physical Reality” /12/ has functioned for many years. A lot of well-known scientists publish their papers there. Being absorbed in the nanoworld we should redefine the concept of the consciousness as it is directly related to energy process (N. Tesla and J. Keely spoke about it).

The term “consciousness” is often understood as different processes taking place in the brain when a person is in the state of consciousness. It can be thinking and, for example, solving of some logic problems. It can also be perception of the environment in the form of visual, acoustic and tactile images. The processes have been researched thoroughly for a long time and the research like that is often called the consciousness studying. But when we speak about the term of consciousness we will imply not the processes taking place in the conscious state but the consciousness itself. To avoid confusing with the broader understanding of the term we can introduce a new term “consciousness root”. To make it simpler we will use the same term. Thus when we say the consciousness we imply the consciousness itself that differs the state when something is perceived (realized) from the state when this is not realized. The mystery of consciousness is related with this understanding of the consciousness. As a matter of fact, we do not understand what the consciousness is as such. It might be understood if we rely on the quantum mechanics conceptual analysis. There is an attempt to explain the consciousness mystery /5/ by relating it with the quantum mechanics mystery. The quantum mechanics that has existed for 100 years is mysterious too. We will show how it is related with the consciousness mystery and how the both mysteries are revealed when they are compared.

**Quantum energy paradoxes (based on quantum mechanics).** Why do we speak about the quantum energy mystery? It seems strange that the quantum mechanics, a well-developed science that explained many natural phenomena and created new technical devices, is still a mystery. Many people still think that it is impossible to understand the quantum mechanics (and therefore, the quantum energy). You can know how to work with the

quantum mechanics apparatus but you will not be able to understand it. R. Feynman, the person who made the great contribution into the quantum mechanics said: “Nobody understands quantum mechanics”. Famous quantum and mechanical paradoxes appeared at the beginning of the XX century. The paradox of Schrödinger's cat is one of them. The quantum mechanics paradoxes appear because quantum mechanics is a linear one that is it has the idea of the superposition (the state linear combination). The linear structure of the quantum system is preserved under its evolution. What does the state superposition mean? It means that if there are two states of the quantum physical system, there is the state which is a sum of the states, that is it is their superposition. We can add states in the quantum mechanics as we add vectors and obtain a new state which is called the superposition of the initial states (the state vectors can also be multiplied by a complex number). Nothing of the kind can happen in the classical mechanics. For example, if there is a point particle, it can be in one point and it is its one state. If it is in the other point, there is its other state. The particle, of course, can be in the third, fourth and so on point, and you can not say anything more in the classical physics. As far as the quantum mechanics is concerned, the point particle can be in the superposition of such point-localized states. There is the main difference between the classical mechanics and the quantum one: the state superposition is possible in the latter. The two states which eliminate each other from the classical point of view and are alternative to each other can coexist as the superposition components indeed. Of course, any number of the states that eliminate each other from the classical point of view can be the superposition components. As long as we deal with the microscopic object (such as elementary particles or atoms) state superposition there is no paradox yet. It is just a new characteristic that can be found with the microscopic systems. It is because of this characteristic that they submit to the quantum physics, not the classical one. The possibility of existence of the superpositions for the micro objects is proved by numerous experiments and can not cause any paradox on its own account. The paradoxes appear because macroscopic objects must logically have the state superposition too. The analysis of the micro object measurement proves it. If the measurement procedure is analyzed according to the quantum mechanics, the transfer from the micro object to the macro object is seen. The

microscopic system, let it be an atom or an electron, undergoes measuring. The micro system interacts with the measuring device which is a macroscopic one. Thus the transfer from the micro level to the macro level takes place during the measurement process. The transfer is inevitable as the superposition is to exist for the macro objects too. In other words, the macroscopic objects can be in the superposition of the states which, from the classical point of view, are not compatible with each other and are alternative to each other. The Schrödinger's cat situation is the measuring situation. In this case an atom, which is not steady and can dissociate, is measured. The measurement distinguishes the dissociated atom from the non-dissociated one. A living being (the cat), not a device, is used for the measurement. It makes the situation dramatic and the paradox vivid. The mental experiment of Schrödinger is in the following: a simple device makes the cat's state dependent on the dissociating atom in such a way that if the atom is not dissociated yet, the cat is alive, and if it dissociated, the cat dies. But as long as there is the non-dissociated atom superposition state, there is to be the alive cat superposition and the dead cat superposition too. It seems impossible. So we drive to the paradox conclusion which our intuition can not make it up with. This is the paradox ground. The paradoxes that arise in any science are difficult to solve. However, if the solution is found, it leads to important new results. In our case the quantum mechanics interpretation proposed by H. Everett and called the multiworld interpretation has the paradox solution /5/. The authors developed the idea in the work /3/.

**Quantum reality.** If we speak about the world, which is the quantum one, we can examine its one state, then another drastically different one and drive to the conclusion that there is the two state superposition. In other words, the two worlds, that seem to eliminate each other, can co-exist according to the quantum mechanics laws. Thus, the parallel worlds arise inevitably in the quantum mechanics. It's not a fantasy at all. It is inevitable because of the quantum nature of the world (physicists discovered it while studying microscopic objects). If you ask experts in the quantum mechanics if the science can drive to the conclusion that the parallel worlds do exist, the majority of them will be surprised and answer negatively. It is due to the fact that the parallel world existence belongs to the conceptual fundamentals of the quantum mechanics and the question does not arise

during calculations. That is why only those who discuss philosophical aspect of the quantum mechanics can speak about it. The people have always lived and asked the questions. The American physicist H. Everett made the conclusion on the parallel world existence in 1957 /13/ which was immediately supported by such outstanding scientists as J. Wheeler and B.DeWitt and was not recognized by the society. That is why Everett's interpretation was forgotten and entered the marginal area. Now it is getting paid interest at and there are some reasons for that. The deeper understanding of the quantum mechanics is required for its further development and for giving grounds to new engineering applications that the idea of the quantum informatics includes. The statement of existence of the parallel worlds that shows up in such a strange case as the paradox of Einstein-Podolski-Rosen is of interest to us. It is called the demonstration of quantum nonlocality. They sometimes say that the quantum nonlocality is an instant (superlight) transfer of the signal from one point to another. This formulating is wrong in fact. But the accurate formulating of the quantum nonlocality is a mysterious phenomenon, though there is no signal superlight transfer in it. Now all the strange things are studied and understood by experts. They are included into the concept of the quantum reality. The reality of our world is not as we got used to think of and as it is shown in classical physics. Our world reality is absolutely different. The parallel world existence is one of the main characteristics of the quantum reality. Thus the question why we do not see the parallel worlds and see only one of the possible alternative worlds is quite logical. Because of the question the interpretation of Everett has difficulties in coming into the scientific community. It contradicts with our sense body sensation. If Everett states the existence of the parallel worlds he has to explain why we do not perceive them. The explanation can be in different verbal ways. We prefer the following one: we do not see numerous parallel worlds because they split and are isolated from each other in our consciousness. That is why if an observer perceives subjectively one of the parallel worlds, he can not perceive other ones simultaneously. Other worlds exist and are reflected in the observer's consciousness but in its other components without being compared with each other. The observer has the feeling of only one of the worlds, and there is the illusion that it is the only one that exists. /5/

What conclusions can we make? First of all, there is the illusion of the only reality in our consciousness, however there are different realities. Secondly, the illusion of the only reality appears because the alternative realities split in our consciousness /5/. We made our presentation on the consciousness multidimensional nature /14/ at the recent conference “Ethics and the Future Science” /15/.

**The quantum energy broadened concept.** The next step was proposed in the paper of M. Menski published in the journal “Success of Physics” in 2000 /4/. It states that the interpretation of Everett eliminates logic contradictions in the quantum mechanics and allows getting of something new. The broadened concept of Everett is as follows /5/: Instead of the phrase that the alternative realities are split in the consciousness we will say that the consciousness is the alternative split. This change of the formulating that seems minor is very important. First, it simplifies the theory logic structure and causes unexpected results. Both formulatings understand the term of consciousness as the consciousness as such, that is the consciousness aspect (in its broad understanding) that has not been defined so far. The term of the reality split can not be given the clear definition either. Thus, the formulating of the “split of the alternatives in the consciousness” which is typical to the interpretation of Everett has two ideas that do not have their accurate definition. They seem to be the initial ones and are identifiable only in the second and changed formulation: the alternative split and consciousness is one and the same thing. What does the formulation change cause? First, there is only one concept instead of the two non-defined (the initial) ones. Secondly, the concept is seen from the absolutely different points of view which are the quantum mechanics and psychology. Thus the concept idea is clearer. According to the formulation the consciousness is the ability to see the quantum world with its parallel realities in a special way, that is, to see it as if it has only one reality. The consciousness is the way to perceive the quantum world as if it is the classical one. We can understand why we need this way of the quantum world perception. Life without it would be impossible. The quantum world with all its parallel realities and the quantum nonlocality is locally unpredictable and the local living beings are unable to work out the strategy of surviving in it. If we perceive the parallel worlds separately we

can forecast the future and build the survival strategy in the world which is subjectively perceived as the only one /4/.

**Scientific flash of inspiration and probabilistic wonders.** Let us pass on to the new results caused by the new formulation of the broadened interpretation of Everett. Let us assume that we believe that the consciousness is the alternative split. What is the result of it? There is nothing new from the first sight. The alternatives are split in the consciousness or the consciousness is the alternative split. There seem to be no significant difference in it. But it's not true. If the consciousness is the alternative split we can ask the question: what will happen if we switch off our consciousness? We definitely know that there are many states when the person's consciousness is switched off. We mean the state of dreaming, different types of trance and meditation. If the consciousness is the split of the parallel worlds and alternatives, we switch off the alternative split by switching off the consciousness. Thus, if the consciousness is switched on, we subjectively see only one alternative and one world, and when the consciousness is switched off we can have access to all alternatives at the same time. So, it turns out that when we are unconscious, we can get the information from the bigger database which is inaccessible when we are in the conscious state. Need we be surprised that odd things happen when we meditate, dream or are in the state of trance? Of course, we need not. There are two typical phenomena that are possible only due to the consciousness temporary switching off. The first one is non-logical knowledge that is seemed to stem from nowhere. The usual method used in science is the analysis of what is perceived by the consciousness and of what our fathers, grandfathers and distant ancestors perceived. Everything which is in the consciously perceived world is analyzed and logical conclusions are made. The non-logical knowledge makes the conclusions which are not possible to make on the ground of the consciously perceived information. Why? Because the non-logical knowledge uses the wider database that includes the parallel worlds. More than that, when we are unconscious, we have the access to all possible world states in all times due to the quantum mechanics equation reversibility. We are able to look into the future and see all its versions and understand that we can get much information from such a tank. It is the very source of the non-logical knowledge. Scientific insights of a high level typical to great scientists seem to stem from there.

Great discoveries are made on the way to the non-logical knowledge. The knowledge is obtained spontaneously and it is impossible to trace its origin. Besides, the broadened concept of Everett explains probabilistic wonders. It can be called the reality control. It is not the objective reality control, but that of the reality which man perceives subjectively (all versions of the objective reality co-exist). What will be subjectively perceived next time, tomorrow or next year? All the versions will exist objectively. Which of them the “I” will experience subjectively? It can be controlled if the probability of subjective experiencing of the preferable reality versions is increased. Let us come back to the non-logical knowledge or intuition. The phenomenon can be concretized. What does the scientific flash of inspiration mean? It is the key moment of the research. The main part of the research is the routine work which is done with the help of the rational method within the strict logic and is based on the information accessible in the state of consciousness. But the key moment of choosing and guessing of something that can not be subjective to the logic appears sooner or later. It can be concretized as follows: Let us assume that there is a set of solutions of some difficult problem and we need to choose the correct one. We need not to prove it, as it is impossible, but guess it. It might be not the solution itself, but the trend, the way to search. In order to make the right choice we need to have some truth criterion. So, the intuition helps use not only the truth criteria the researcher has, but also those that will appear in the future. For example, he can look into the future and see that if he chooses the certain version of the solution, his choice will be proved as the correct one later. The choice is made on the unconscious level as it can not be made on the conscious one. The subjective feeling is as if the certainty in the correct solution comes unexpectedly and from somewhere. It is the scientific flash of inspiration which is the non-logical knowledge in this case. There are a lot of examples of such flashes of inspiration. By the way, everyday life problems are solved on this ground. All people have the ability, but they use it in different extent. The flashes of inspiration are instant and unmotivated. They can come at work, or while man is resting or sleeping, or just as he has woken up. When the flash of inspiration comes, there is the absolute certainty in the solution correctness, though there is no rational proof of its truth, it will appear only in the future /5/.



**The material and the spiritual (ideal).** The psychologist C. Jung and the physicist W. Pauli were the first to discuss the link between the consciousness and the quantum mechanics in the 1930s. Unfortunately, the results were practically unknown. Jung and Pauli did not publish them and only mentioned them in the letters to their friends. The friends apparently did not understand the arguments or did not believe them. The ideas of Jung and Pauli have been discussed just recently. Both researchers had a task to find the links between psychology or the certain psychological phenomena and the material phenomena described in the quantum mechanics. The choice of the trend was of genius by itself that time. Their main merit was in understanding of the fact that the psychological phenomena are related to the quantum mechanics characteristics that distinguish it from the classical physics. Jung illustrated the link between the psychical and the material by drawing of two cones joined by the points. He showed the psychic phenomenon area as one cone, and that of the material as the other one. V.V. Puck /16/ examined the issue. The common point which is the point for both cones is that is common for the material and the spiritual. Pauli and Jung thought that the contiguity took place through the quantum mechanics. The two cone point corresponds to the consciousness phenomenon in the broadened concept of Everett. The consciousness is common for both the material and the psychic because the consciousness is that which is in our head from one hand and it also is the alternative split which occurs in the quantum mechanics from the other one. The broadened concept of Everett allows clarifying of the illustration proposed by Jung and speaking about the fact that the material and the spiritual join not in one point but have a field of the phenomena common to them. They join very softly in the field and transfer into each other gradually. The phenomena that can not be referred either to the material sphere or the spiritual one take place in the consciousness "field". The probabilistic wonders are the most important example of the phenomena. These are wonders which can not exist in the material world and natural science from one hand. But they are only probabilistic wonders from the other one. According to the probability theory we can come across the phenomena that can happen with a very little probability. It is significant that the phenomenon probability equals to zero. Then it might happen even with the little probability. Thus such specific phenomenon as the

probabilistic wonder can be considered the natural one (accidental coincidence) and the wonder (caused by our consciousness). It can not be definitely referred to the material or the spiritual sphere. The objective relativity occurs in this case. Of course, the objective relativity happens not for all events, phenomena and factors, but only for some of them that take place in the consciousness sphere. We will never be able to say whether the phenomenon exists objectively or whether it is the result of our consciousness activity /5/.

Doctor of Philosophy and psychoanalyst A. Mindell, who was a graduate of Massachusetts Technological Institute, wrote in his fundamental work “The Quantum Mind” /7/that the edge between physics and psychology is rather fuzzy today. He shows in the chapters “Consciousness in Mathematics” or “Sensitive Quantum Mechanics” that the quantizing of the consciousness as the energy quantizing is the fundamental characteristic of the Universe. This characteristic is not used and understood sufficiently. We hope that the paper will catalyze the process understanding which is not easy at all. A. Mindell wrote in the chapter “Energy and the Future of the Human Race”: “The entropy law – the so-called thermodynamic second law-discovered by Maxwell is based not on the commonly recognized Universe. If the system understood itself, as Maxwell assumed and mediums, mystics and shamans perceive, the world would create the order that would return the thermodynamic second law” /17/. It is quite a bold supposition; however let it remain a hypothesis.

**Conclusions.** Thus, a new scientific revolution is taking place or its final stage that was marked by the quantum mechanics creation. Many physicists have tried to unite the consciousness concept with the quantum mechanics since 1980s. Some contours of the quantum energy are given in the paper. The proposed trend is exceptionally symbolic as its appearance marks the final stage of the scientific revolution that started with the quantum mechanics. From our point of view the key mechanism is ethic algorithms of the Universe.

## References:

1. A.V. Levshov. Heading to the Clue of the Phenomenon of N. Tesla (Interdisciplinary Approach). / A.V. Levshov, S.G. Dzhura //Proceedings of Donetsk National Technical University. Series: "Electrical Engineering and Energy"- 2007. - Issue (128). – P. 11-13.
2. A.V. Levshov. Heading to Metaenergy/ A.V. Levshov, S.G. Dzhura, V.I. Chursinov. //Proceedings of Donetsk National Technical University. Series: "Electrical Engineering and Energy"- 2009. - Issue (158). – P.152-155.
3. A.V. Levshov. Multidimensional Energy / A.V.Levshov, S.G. Dzhura, V.I. Chursinov. //Proceedings of Donetsk National Technical University. Series: "Electrical Engineering and Energy"- 2011. – Issue 9 (158). – P.108-112.
4. A.V. Levshov. Ethic Algorithms of the Universe/ A.V. Levshov, S.G. Dzhura, V.I. Chursinov// Newsletter of SFU-DonNTU. Proceedings of the 11<sup>th</sup> International Practical Seminar "Practice and Outlooks of Partnership Development in High School": in 3 volumes. – Taganrog: Publishing House of SFU, 2010.vol.1. – №10. – P. 87-107.
5. M.B. Menski. The Reality Quantum Concept and Consciousness/ B.M. Menski//Delphis/- 2011/- №3 (67).
6. T. Dimitrov. They Believed in God: 50 Nobel Prize Winners and other Scientists/ T. Dimitrov. : <http://www.scribd.com/doc/57443177/4/>
7. Theological School of the University of Harvard. - <http://www.hds.harvard.edu/>
8. Theological Faculty of Oxford University. - <http://www.theology.ox.ac.uk/>
9. Theological Federation of the University of Cambridge. - <http://www.theofed.cam.ac.uk/>
10. Education: World Research. - <http://www.oim.ru/>
11. K.E. Tsiolkovski. Shield of the Scientific Belief / K.E. Tsiolkovski. - M.: Samoobrazovanie, 2007.
12. Journal "Consciousness and the Physical Reality". - <http://sfr.folium.ru/>

13. Hugh Everett. "Relative State Formulation of Quantum Mechanics" / Hugh Everett / Reviews of Modern Physics. – Vol 29. – (1957). – pp. 454-462. –<http://www.univer.omsk.su/omsk/Sci/Everett/paper1957.html>
14. S.G. Dzhura. Multidimensional Consciousness/ S.G. Dzhura//Oriflamma.- 2011. №29. – P. 20-26.
15. Ethics and the Future Science. <http://ethics.roerich.com/>
16. V.V. Puck. Puzzles of the Space, Time, and the Objective Reality /V.V. Puck: <http://www.roerich.com/zip/zagadki.zip>
17. A. Mindell. The Quantum Mind: the Edge between Physics and Psychology/ A. Mindell. – M.: Belovodie, 2011.: [http://www.koob.ru/mindell/kvantovii\\_um](http://www.koob.ru/mindell/kvantovii_um)

### 3.5. Multidimensional energy

A.V. Levshov, S.G. Dzhura, V.I. Chursinov.

*The theory of superstrings, loop gravitation and matter gas and kinetic theory is analyzed in the paper. The hypothesis of the matter, energy and information conservation is proposed. The term “multidimensional energy” is introduced. The outlooks of its development are shown.*

**Introduction.** Science has been working at creation of the theory of everything during last two centuries. We think that the term “energy”, which is one of the most mystical one, is waiting for its gnosiological and ontological concept to be developed.

**Energy conservation law of the XXI century.** As far as the majority of substances on the Earth can have a solid, fluid and gas state, the transfer from one of them to other ones is easy. Thus the energy conservation law can be supplemented by the following: it is the matter, energy and information conservation law. Let it be a hypothesis. Why? The answer can be found in the idea of the multidimensional Universe the theory of which is being developed actively nowadays.

**The multidimensional Universe.** The theory of the multidimensional Universe was born at the University of Oxford, but it has not been recognized and included into physics textbooks so far. One of the popularizers of the theory /1-28/ B. Greene says /21/: “The string theory is

a part of the more grandiose synthesis which has some mystic title – M-theory”. According to the theory our space is 11 dimensional. Three dimensions are at the bottom (if to take into account the time, there are four of them). The other ones are difficult to explain and understand visually as we do not have their analogues. However, some artists, such as M.Escher and J.Bosch, showed them as paradoxes. B.Greene explains it in rather an interesting way in his book “The Smart Universe”.

**Historical viewpoint of the problem.** In 1905 Einstein showed that light waves can behave as particles do; it means that they can be described as energy packs known as photons. By 1920 Schrödinger had been sure in the opposite: particles, electrons for example, can behave as waves do. The idea was stated by the French physician Louis de Broglie who was awarded the Nobel Prize for the hypothesis. To demonstrate it to his students he shot electrons into a cathode ray tube similar to the TV. The electrons went through a tiny hole and a small light point was to appear on the display. Concentric wavy circles were discovered instead. They normally are expected to appear when a wave, not particles, goes through the hole /29/.

As Maxwell took Faraday’s fields and got Maxwell equations for light, Schrödinger took the particle-wave of de Broglie and got the equation of Schrödinger for the electrons.

However, there is one problem that does not give rest to physicists today. If the electron is described as the wave, what oscillates in it? The physicist M. Born gave the answer: these waves are the waves of probability. They only inform on the probability of discovery of the certain electron at the certain point and time. In other words, the electron is a particle, the probability of discovery of which is given by the Schrödinger wave. The higher the wave is, the more chances we have to discover the particle in this very point.

The ideas of chance and probability turn out to be in the heart of physics, the science that used to give us accurate forecasts and detailed trajectories of any objects, from planets and comets to cannonballs.

V.Heisenberg formalized the fact having proposed the uncertainty principle – the postulate on impossibility to know the exact speed and position of the electron at one and the same moment. It is impossible to define its energy at the given period of time either. All fundamental laws of the common sense are broken at the quantum level: electrons can escape

and appear again at another place and be in some places simultaneously. Ironically, both Einstein, the godfather of the quantum theory who took part in revolutionary transformations in 1905, and Schrödinger, the author of the wavy equation, were horrified by the random processes in fundamental physics.

Einstein wrote: “The quantum mechanics commands great respect. But my inner voice tells me it is not the thing we need. The theory explains much, but hardly drives us closer to the God’s mystery. At least I can be sure of one thing: I know he does not play dices”/29/.

In other words, chemistry which studies and explains a molecule structure is based on the idea that electrons can be at several places simultaneously; although teleportation is allowed on the quantum level, to see the strange event at the macroscopic level we will have to wait till our Universe collapses or even longer. Can we use the quantum theory laws and create the vehicle for teleportation of the objects in accordance with some requirements as it is in science fiction works? You might be surprised, but the answer is definite: yes, we can!

In 1994 P. Shor from Bell’s laboratory showed that it was a child’s play for the quantum computer to fold multipliers. The discovery made the community be interested in it. In principle, the quantum computer might be able to crack all codes in the world and destroy the modern computer safety system. The first country which will be able to create the system will reveal the deepest mysteries of other states and organizations.

One of the main arguments against the string theory is that it is impossible to check it. Its opponents say that to make a real check they would need the particle accelerator of the galaxy size /29/.

The critics forget that sometimes it is easier to get a result indirectly. No one has visited the Sun to make direct measurements, but we can analyze sun light spectral lines and therefore we know that the Sun consists of hydrogen.

In 1939 Einstein wrote the paper in which he proved that the dark stars like that could not be formed in a natural way. The main argument was that the dark stars could not be discovered as they were invisible. Today, due to Hubble Space Telescope, we have the proofs of existence of collapsars. We are sure there are billions of the collapsars in the galaxy centres. There are tens of wandering collapsars in our own Galaxy. But the

matter is that the data on the collapsars was obtained indirectly through studying of the accretion disk that rotates around them.

More than that, many “untestable” theories become testable in the course of time. It took two thousand years to prove atom existence that had been forecasted by Democritus. In the XIX century the physicist like Boltzmann might be badgered to death. Today we have excellent photos of atoms. The great skeptic Pauli introduced the concept of the neutrino, the particle that is so elusive that it can fly through the lead ball of the Solar System size and interact with nothing. Pauli said: “I made an awful sin; I introduced the particle that can not be observed”. It was impossible to discover the neutrino because the unusual particle was thought to be a fantasy for some tens of years. Today we can create neutrino beams /29/.

**From the ether to the matter gas and kinetic theory.** People have had the idea of the ether since the ancient time. It was thought to fill all the space and be the medium that transfers force interaction. Democritus named the ether particle the omer. By the end of the XIX century the physics building had been considered built and perfect. It consisted of two separate “rooms” — mechanics and electrodynamics the links between which was made through the experimentally found ampere. Naturally, there were two systems of units: the mechanical (CGS or MCS) and electromagnetic (MCSA). Of course, the problem of the matter single theory, at which Einstein was working the main part of his life, appeared /30/.

The experiments on discovery of the ether have been carried out since 1881 that is for more than 100 years. They are extremely difficult and have always obtained negative results. In 1905 it allowed Einstein stating publically that there was no ether in the nature. In October 1902 the editor of the journal “Self-education Newsletter and Library” asked D. Mendeleev to write a paper “An Attempt of Chemical Understanding of the World Air”. It, to the researcher’s surprise, “was read with interest in the circles which it was not aimed at”. Private letters of some foreign colleagues and printed references of some English and American journals prove it. Many scientists asked D. Mendeleev to send them the paper, and he had to publish the paper again in St. Petersburg in July 1905. He stated that “the ether was heavy substance” and would help understand the uniformity of

the Universe chemical composition as there “would be exchange between all the worlds through the ether”. How does the interaction occur?

The concept of field always reaching infinity introduced by M. Faraday was of use. The fact that the field had paradox characteristics was not thought significant. Nobody worried that the concept was not able to explain a number of experimental facts. The unexplainable experimental facts were named paradoxes. There appeared the opinion that the paradoxes are an ordinary phenomenon, a sign of rapid development and they should be considered postulates that is statements that should be taken without any proof. There were more than 30 postulates-paradoxes in the XX century. They are: pair appearance, paradox of Seeliger and Heisenberg’s uncertainty principle /30/.

However, not all researchers agreed with the statement. They split into two groups: the followers of close assistance and the adherents of the idea of a remote action. By the way, the Nobel Prize Committee has never recognized the relativity theory (absence of the air and the remote action through the field). Einstein got the Nobel Prize not for his relativity theory, as many people think, but for the photoeffect laws. But we should give credit for him: in his papers issued in 1920, 1922 and 1926 Einstein was the first to write that the structure of the Universe was impossible without the ether. But nobody was interested in it. The paradox regularity was taken as permissiveness and it was thought that the right theory must be “crazy”. So, physicists let themselves go and endowed discovered elementary particles with different extravagant characteristics such as “enthralment”. The physicists defied paradoxicality which was in fashion.

The academician V.F. Mitkevich, a professor of Leningrad Polytechnic Institute, was one of the followers of the close action. His open discussion with the academician I.M. Franc caused a heart attack and he died in 1948. In 1980 a postgraduate student of Prof. N. Bogolyubov was thrown off a suburban electric train and died because he had disproved the relativity theory. Theoretical arguments were solved this way that time... V.A. Atsyukovski was one of the students of V.F. Mitkevich. After his graduation from Leningrad Polytechnic Institute he was employed at the Central Aerohydrodynamic Institute in Zhukovski. The first engineering tasks he was solving faced him to the physical theory paradoxes. He, unlike us, did not take them for granted. He understood the necessity of revision



of the fundamentals of the physical theory and set about to solving the grand task /30/.

The first thing he did was turning to sourcebooks. He was shocked by the fact that the Lenin's Library cards on the experiments on discovery of the ether wind were empty! Nobody has paid any interest to it for 80 years! V.Artsyukovski made first ever translation of the papers on the experiments on discovery of the ether wind into Russian and then published them as a separate book at his own expense /31/. He analyzed the papers, found mistakes in the experiment carrying out and wrong interpretation of the results /30/.

All the researchers that considered all gas laws perfect did not attach importance to the inner friction (viscosity) of the ether gas, the bottom layers of which are carried along by the Earth when it moves. That is why the researchers obtained the speed of 3, 6, 8, 10 or even 18 km/s instead of the expected 30 km/s, but considered it the experiment mistake. We will have to wait and see when the experiments will be carried out at the Earth satellite and give the sought-for 30 km/s.

It is impossible to discuss all the papers of V.Artsyukovski in the paper, so we will pass to the main results /30/.

The ether is a real gas of the size of  $10^{-45}$  m that fills the space and is in the Brownian motion with Maxwell velocity distribution, inner energy, viscosity, pressure and all other parameters of the real gas. Proton, as the substance structure basis, is the amer toroidal vortex.

Tornado is the most famous of gas vortexes. Its diameter is bigger at the ground and the clouds because of energy losses spent for friction. The law of energy conservation (it always cats) causes the vortex to roll up into a ring and transform itself into the toroidal vortex to minimize its friction losses. The toroidal vortex is more stable and can exist for a long period of time. But it also splits into smaller ones. It occurs because of the following reasons /30/.

When the ether (or any other real gas) moves, its pressure reduces in the direction perpendicularly to the motion (the pulverizer effect). The sum of hits of the Brownian particles on the side wall depends on the gas speed along the wall: the higher the speed is the fewer hits we have. Their sum is the gas pressure. In this case the superposition principle - the independence of the amer two movements (the Brownian and directed) - is observed.

It is in this way that instability of the plasma ring develops in elementary particle accelerators called tokomaks. The mechanism causes the pressure of the space vortex in the Galaxy centre because of which protons appear continuously. The ether circulation takes place in the form of the ether screw flows in the Galaxy sleeves directed to the centre due to the external pressure where the giant toroidal vortex is formed during the ether flow collision. The vortex is then divided to the size of the proton. Thus the substance in the form of the atoms of the periodic table, molecules, minerals, planets and stars is born in the Galaxy centre and diffuses from the centre to the periphery along the sleeves through the ether wind /fig.3)!

The possible but extremely improbable and slightest fault causes the ring screw. In other words, the proton has two movements: toroidal rotation inside the ring and ring rotation along the circle. The first one is taken as the magnetic field with its intensity  $H$ , the second one is taken as the electric field with its intensity  $E$ .

This means that there are no electric charges as the separate reality. There is no magnetic field either. All this is just the ether vortex influence. We do not need the idea of the field in the frameworks of the concept. More than that, if we can turn electric and magnetic phenomena to the mechanics of gas vortices, this means that V. Atsyukovski created the first ever single theory of the matter, and this theory is gas and kinetic. Thus, the two systems of units can be combined and this was done by V. Atsyukovski /32-33/.

The real ether gas surrounding the proton is involved into the movement. We should pay attention to the fact that the ether mass caught from outside is increased in case of the toroidal movement, just as the sphere volume, and in case of the ring movement – as the circle square, that is in proportion to the radius cube in the first case, and the radius square in the second one. Therefore, according to simple geometric calculations, the force transferred to the ether outer layers is to be reduced inversely to the radius cube in the first case and the radius square in the second one. But, according to the laws of Coulomb and Biot-Savart-Laplace, electric and magnetic forces are reduced in such a way depending upon the distance. The directions of electromagnetic interactions are defined by the famous

left-hand and right-hand rules. The ether and gas vortexes and gyroscopes interact exactly like this.

The involved flow will not fit into the proton ring hole at the certain moment and will be closed and form the bound vortex (the term introduced by N.E. Zhukovski). The bound vortex speed outer vector is opposite to the proton vortex vector. If the proton is not just a hard ball running along the orbit, but the amer vortex, Heisenberg's uncertainty does not need any explanation /30/.

The neutron is formed under two proton approaching. The pressure is reduced very much in the boundary layer because of the big gradient of the ether flow alternate speed. The outer forces bring the protons together so much that the boundary layer is pushed from the chink between them and covers one of the protons. Friction and viscosity in the boundary layer are always very low. The boundary layer that covers one of the protons is something analogous to the slider bearing; the ring rotation of the proton surrounded by the boundary layer does not go through the boundary layer which is analogous to the charge screening that is transforms it to the neutral particle. If the system splits into two initial particles, the boundary layer exists for 12 minutes, and that explains the existence of separate neutrons.

Using one and the same mechanism of the ether vortexes interaction V. Atsyukovaski decoded the structure of nuclei and electron shells of all the atoms of the periodical table /32-33/. All known forces – electric, magnetic, weak nucleus, strong nucleus and gravitation were reduced to gas and kinetic interaction of the ether toroidal vortexes.

The gravitation mechanism is to be given a separate explanation. Gravitation forces appear under the reduction of the pressure close to the rotating vortexes. As a result, the outer pressure brings the vortexes together. M. Lomonosov interpreted the gravitation interaction not as bringing matter mass together, but as pushing to each other by the hits of Brownian particles. There are more hits outside the two body system then inside. Isn't it clever!

There is an extra factor in this explanation of the gravitation in the law of universal gravitation. It gives more rapid than inversely quadratic reduction of the gravitation force with a distance. The factor is reduced to zero on big distances. In other words, there are areas of the Universe where

there is no gravitation. Seeliger paradox is solved in such a way (if the gravitation exists in infinity, why are star systems not brought together and do not fall on each other?). More than that, huge distances among the star systems are defined by this very gravitation characteristic. The distances are too big for the gravitation forces between them to be absent /30/.

The gravitation behavior can be explained from the geometrical point of view. Let us imagine us an amer and look at the situation with its “eyes”. The vivid size of the mass is reduced when it goes farther from the gravitation mass. There is no big chance for the amer which is in the Brownian movement to hit it. This probability is reduced to zero when the vivid size of the gravitation mass equals to the vivid size of the amer.

Let us summarize all above mentined. According to the concept of the single mechanism of interaction of the ether toroidal vortexes Atsyukovski created the single gas and kinetic theory of the matter, reduced two systems of units into one, explained all the natural forces and paradoxes of physics of the XX century.

Examining the ether and dynamic nature of the ionic and covalent bond, we can make the conclusion that all chemical processes (including the ones in the earth interior) and biological and chemical processes in the bodies of animals and man are accompanied either by absorption of the missing from the space or by discharge of the extra ether into the space. Such phenomena as the earth widening, ocean crust movement, roaring 40<sup>th</sup> latitudes, Antarctica glaciations, continent floating towards the north that resulted in isolating of the Arctic Ocean and forming of the Gulf Stream as a convective stream of energy exchange between the hot tropical and the cold Arctic oceans can be also explained. If to speak about man, such phenomena as Kirlian effect, aura of saints, dowsing, telekinesis, biolocation, clairvoyance and others are understandable in general /30/.

Thus who (or what) prevents us from assuming that the principle is not spread further more and the amer is not just a “hard” ball but the toroidal vortex from the ether -2 and that the ether-3, ether-4, ether-5 and ether-6 could exist?

The great Indian philosophy shows that all natural bodies are septenary. We underline the word “natural”. Man’s inventions – cameras, computers, cars – do not have seven bodies. That is why their “injuries” are not healed by themselves, they need repairing /30/. We do not mention the

famous four (three coordinates and the time). In general, according to the string theory or its version – M-theory- there are 11 dimensions.

**Conclusions.** The energy outlooks are great and they can face the time challenges. The root of the future inventions is to be looked for in the multidimensional energy and its highest dimensions. It's not in vain that there are more and more publications on vortex engines, N.Tesla's experiments and Kili engines. The mankind is to be worth of the energy as it is not an engineering problem, it is an ethic one. The knowledge on application of the highest dimension energy is in the sphere that can allow entering only the man with the world outlook of the development noospheric stage.

#### References:

1. B.M. Barbashov, V.V. Nesterenko. Relativistic String Model in Hadrons Physics. M.: Energoatomizdat, 1987.
2. V.I. Ogievetski. L. Mizenchesku. Symmetries among Bosons and Superfield Fermions. v.117, № 12. 1975.
3. M. Greene, J. Shvarts, E. Vitten. Theory of Superstrings. M.: Mir, 1990.
4. S.G. Gunov. Introduction into String Duality // UFY, v. 168, № 7. 1998.
5. A.V. Marshakov. Theory of Strings of Theory of Field? // UFY, v. 172, № 9. 2002.
6. Douglas M.R. Basic Results in Vacuum Statistics. arXiv: hep-th/0409207.
7. Mersini-Houghton L. Wave functions of the Universe on the landscape. arXiv: hep-th/0512304.
8. Mersini-Houghton L. Cosmological Implications of the String Theory Landscape. arXiv: hep-ph/0609157.
9. Rudnic L., Brown S., Williams L.R. Extragalactic Radio Sources and the WMAP Cold Spot. arXiv: 0704.0908.
10. Kashlinsky A., Atrio-Barandela E, Kocevski D., Ebeling H. A Measurement of Large-scale Peculiar Velocities of Clusters of Galaxies: Results and Cosmological Implications. arXiv: 0809.3734; Kashlinsky A., Atrio-Barandela F. Ebeling H., Edge A., Kocevski D. A new measurement of the bulk flow of X-ray luminous clusters of galaxies. arXiv: 0910.4958.

11. Mersini-Houghton L., Holman R. 'Tilting' the Universe with the landscape Multiverse: the 'dark' flow. arXiv: 0810.5388.
12. Ashtekar A., Lewandowski J. Background Independent Quantum Gravity: a Status Report. arXiv: gr-qc/0404018.
13. Rovelli C. Loop Quantum Gravity, [www.livingreviews.org/lrr-2008-5](http://www.livingreviews.org/lrr-2008-5).
14. Pullin J. Knot Theory and Quantum Gravity in Loop Space: a Primer. arXiv: hep-th/9301028.
15. Oriti D. Space-time Geometry from Algebra: Spin Foam Models for Non-perturbative Quantum Gravity. arXiv: gr-qc/0106091.
16. Perez A. Introduction to Loop Quantum Gravity and Spin Forms. arXiv: gr-qc/0409061.
17. Bojowald M. Loop Quantum Cosmology, [www.livingreviews.org/lrr-2008-4](http://www.livingreviews.org/lrr-2008-4).
18. Smolin L. The Plebansky Action Extended to a Unification of Gravity and Yang-Mills Theory. arXiv: 0712.0977.
19. Freidel L., Kowalski-Glikman J., Starodubtsev A. Particles as Wilson Lines of Gravitational Field. arXiv: gr-qc/0607014.
20. Bilson-Thompson S., Hackett J., Kauffman L., Smolin L. Particle Identifications from Symmetries of Braided Ribbon Network Invariants. arXiv: 0804.0037.
21. B. Greene. The Elegant Universe. Superstrings, Hidden Dimensions and the Final Theory Search. M.: Editorial, URSS, 2005.
22. Translation of the Official Site of the Superstring Theory ( S.A. Pavyuchenko), [www.astronet.ru/db/msg/1199352/index.html](http://www.astronet.ru/db/msg/1199352/index.html).
23. Pierre J.M. Introduction into the Superstrings. [www.astronet.ru/db/msg/1185844/index.html](http://www.astronet.ru/db/msg/1185844/index.html).
24. R. Busso, J. Polchinski. String Theory Landscape // In the World of Science. 2004. № 12.
25. A. Jankshs, G. Peres. Searching for the Life in the Multi-Universe // In the World of Science. 2010. № 3.
26. L. Smolin. The Space and Time Atoms // In the World of Science. 2004. № 4.
27. M. Bodzhovald. Hunting for the Jumping Universe // In the World of Science. 2009. № 1.

28. G. Venetsiano. Myth on the Time Start // In the World of Science. 2004. № 8.

29. M. Kaku. Physics of the Impossible. – M.: Alpina Non-fiction, 2010.

30. A. M. Stepanov. Ether Dynamics and the Highest Worlds //Delphis, №2 (62), 2010.

31. The Ether Wind. M.: Energoatomizdat, 1993.

32. V.A. Atsyukovski. General Ether Dynamics. M.: Energoatomizdat, 1990.

33. V.A. Atsyukovski. General Ether Dynamics. M.: Energoatomizdat, 2003.

## **Chapter 4. Pedagogic algorithms and their implementation**

### **4.1. Philosophical approach to the analysis of modern pedagogy**

#### **(in application to Ukraine)**

*S.G. Dzhura*, Donetsk National Technical University

*The communication hypothesis (Knowledge transfer) which is essentially important for creation of remote courses of new generation, for power engineering students in particular, is given in this article. The problem of the aims of pedagogy is laid down. Ways of its solving through Gödel's theorem and concept of metapedagogy are shown.*

**Introduction.** As the modern state of education reflected in pedagogy (both in theory and practice which corresponds to its laws, principles, methods and ways) shows, it is a problem polyhedron the analysis of which allows starting with the main problem, which is the goals of pedagogy the ideals of which are not in demand today.

**Pedagogy objective function.** We suppose that pedagogy can be analyzed with the help of dialectic approach. We can sort out 2 trends (they will be discussed below): fulfillment of its utility function – search of regular links between teaching, personality bringing up and development and design based on models, programmes, technologies and methods of the

teaching and bringing up. The second trend is not usually discussed; at least the author is not familiar with any publications on the subject matter. It is the other side of pedagogy and science in general which corresponds to its coming to the new level (the level is called the meta-level and the science is called meta-pedagogy correspondingly further on in the paper). It is the main goal of science - search for the truth. That is, while fulfilling its utility function any science serves to solve the problems of existence and reproduction of man as a species. Ernest Neizvestni explains the cross symbol in such a way: the horizontal bar stands for what we are to do for our earthly life (to eat something, to live somewhere etc.); the vertical bar stands for what we are to do for the Eternity. The vertical is the main component of the cross (it is bigger than the horizontal) and the symbol of the search for the truth, which pedagogy is aimed at (it's its super goal). In this case pedagogy, as any other science, comes back to its source – philosophy.

As the goal of any pedagogic process can be described in terms of the optimization theory, the process can be considered the objective function OF (in general it is multicriterion with its weigh factors) having its constraint zone CZ (financial, time, etc.).

$$\begin{cases} F(x, y) \Rightarrow \min / \max : (OF); \\ x \leq CZ \leq X : (CZ) \end{cases} \quad (1)$$

University is aimed at giving the specialist qualification characteristic level (knowledge and skills). It is the objective function of the university staff in the constraint frameworks (time, program possibilities, teaching loading and pedagogic and psychological characteristics of the audience that is able or unable to get the knowledge).

Now the university (and not only it) strives for giving its graduate a maximum of knowledge although we understand that it is impossible to give all the knowledge in the time constraint and that of abilities of an individual and a teacher as it takes all your life.

**Research contradiction and hypothesis.** We think that the current Ukrainian pedagogy is ill in the disease which is common for the official science. It has lost its initial practical goal to search for the truth and implements only its utility goal aimed at fulfillment of the social order /1/. It can be observed on the example of distant learning as it is just a form of extra-mural education. The statement of Prof. Stefanenko proves it /2/:



“The optimality criterion for the distant didactic system at the given moment or period of time is defined by 1) general system efficiency or **the social order** that stipulates for the didactic system type and gives the dominant level of getting information by a student and 2) functional efficiency as the speed of transfer of knowledge and skills providing the given level of their learning under the minimal expenses”.

The author of the paper supports another objective function which does not deny unoriginality of the first one and is the only one so far. P. Belikova, N. Roerick's biographer says: “The world politics or economy have never been and will never be the crucial points of the evolution. The evolution is not aimed at creation of the man that thinks correctly. The aim is to create the man that is able to think by the space categories. Politics, economy, and all public formations created by them teach the man to know the matter only on minor and temporary examples. It would be ridiculous to think that justice or injustice of these short-lived forms of the man's social life is a yardstick of the space mind” /3/. The better the country fulfills its evolution idea the closer to the mankind's development it is. The countries that do not fulfill their evolution sense leave the Earth. Here is the indirect proof of the above: “The space evolution is taking its normal course. Dark forces are unable to stop it. The Earth is a particular case that does not matter in the infinity. Every earthling that joined the evolution is involved into the world life flow. The one, who is against the evolution, dooms himself to regress and the final destruction. The evolution wastes are destroyed coming through a long and painful decay stage. You can't be against the evolution for a long time being not punished for it. It is better to join it. The fate of some people, nations and even races that do not correspond to the evolution is sad: they are swept from the life arena. The decay and degeneration may take ages. We know the nations that used to be grand and now are nobody. The Bushmen and the Australians are the remains of the races that used to be grand. The evolution is not limited by the Earth. The way along the stars is endless. Those who go the way often do not know their purpose. The man's fate is great but it is to be understood. Otherwise the man can miss the most important things” /4/.

The idea is supported by L. Gindilis /5/, who observed the stages of science forming and emphasized the values that were typical to the research in the period of experimental natural history forming. It is universalism,

collectivism, unselfishness and organized skepticism. In the second half of the XX century science was an appendage of high technologies and the research value dimmed. Unfortunately, it is not the truth understanding but profit, business and the social order that are important.

Thus the majority of the research is aimed at solving of the social demands of the society. Pedagogy and other science are not searching for the truth (that is not fulfilling its main mission) and are servants of business and democracy that lead the country to the abyss. New notional ideas of pedagogy are not in demand in Ukraine. Some might protest against the statement, but we should make the issue clear. The author of the paper submitted five papers on the problem of higher education to the leading Ukrainian pedagogic journal. The papers were not paid attention to as the editor and experts could neither support nor refute the ideas discussed in them. The journal even does not have the rubric in which the discussion of pedagogic ideas can be organized. The author made presentations at different international conferences, world congresses and his papers were published in journals and proceedings. Actually it appears that such “strange” scientists would rather make presentations not in their native country but somewhere abroad. We would like to mention some historical facts as to the first European computer that was created in Ukraine (Kiev). Nevertheless, we go on buying our products abroad and suppressing the fact.

Why do not we ask the questions? We need to give the interested experts the chance to speak and to discuss the issues in the rubrics of the corresponding journals otherwise pedagogic will never have development outlooks.

The next group of significant problems is as follows: what knowledge, in what amount and how is to be given to a student. Great educators of the past said: “Education is aimed not at a sum of knowledge but at the thinking correct way and moral education” (M.V. Lomonosov) /6/. L.Tolstoy wrote: “Not the knowledge amount is important, but its quality. You can know much, but do not know the most significant things” /6/. The words are prophetic.

**What is the truth?** Many outstanding thinkers tried to find the answer. According to the Wikipedia the truth is “a gnosiological characteristic of thinking in its relation to its subject-matter”. The most

famous definition of the truth was proposed by Aristotle and formed by Isaac the Israeli and accepted by Thomas Aquinas and the entire scholastic philosophy. The definition is as follows: the truth is *conformitas seu adaequatio intentionalis intellectus cum re* (intentional agreement of the intellect with the real thing or correspondence to it). We will try to develop the idea of the reality in the form which is defined by modern physics (the string theory, the 11-D reality) and will correct the subject-matter and the objective function of pedagogy and, possibly, science as a whole. The task is ambitious! E.P. Blavatskaya /7/ fully discloses the problem. Unfortunately, hardly anybody will pay attention to it in the education current paradigm. But it shouldn't be like that!

**The problems the research faces.** The idea of the truth in philosophy coincides with the complex of basic concepts that allows differentiating between the true and not authentic knowledge according to degree of its principle ability to be coordinated with the reality and its own discrepancy and consistency. According to S.U. Goncharenko /8/ the research (interdisciplinary) is not carried out in Ukraine. We hope to start it at least. The reasons for that are as follows (according to Prof. G.S. Belimov and his latest paper submitted to our journal /9/):

“While preparing the material I asked one and the same question to some Doctors of Science and professors from different universities: why does not the academic science accept esoteric knowledge as an element of knowledge. I summed up the answers and sorted out three main aspects. The first is the so-called integral world outlook which the native and foreign science is proud of. It assumes that all main things are understandable once and forever and does not accept any changes and doubts.

The second aspect is the original subculture of the academic science caused by the system of certain paradigms the breakage of which is punished.

The third aspect is self-seeking and selfish: the majority of researchers like being honoured, bonuses, titles, premiums and will never refuse of additional privileges and therefore will support the system even if it is false.

The reasons esoteric and truth are not respected are the same. N. Berdyaev was absolutely right when wrote: “The modern civilization is

based on lie”. There is a feeling that the volume of the all-round lie is approaching its critical mass; it annoys many people and they are bored with it.

All the professors noted that the academic science both in Russia and in the world is in a deep ideological and methodological crisis.../9/.”

You can wear the rouse-coloured spectacles for some time. It is 2012... The truth category in physics, chemistry, history, sociology and pedagogic has a dual characteristics. On one hand the truth is the goal of scientific knowledge in its traditional understanding and on the other hand it is the independent value that provides the possibility of the scientific knowledge to coincide with the objective reality and be the complex basis of solving of theoretical and practical tasks. The truth definition is based on the famous model “was checked” / “was not checked” although many physical and pedagogic characteristics can be felt only, but not checked.

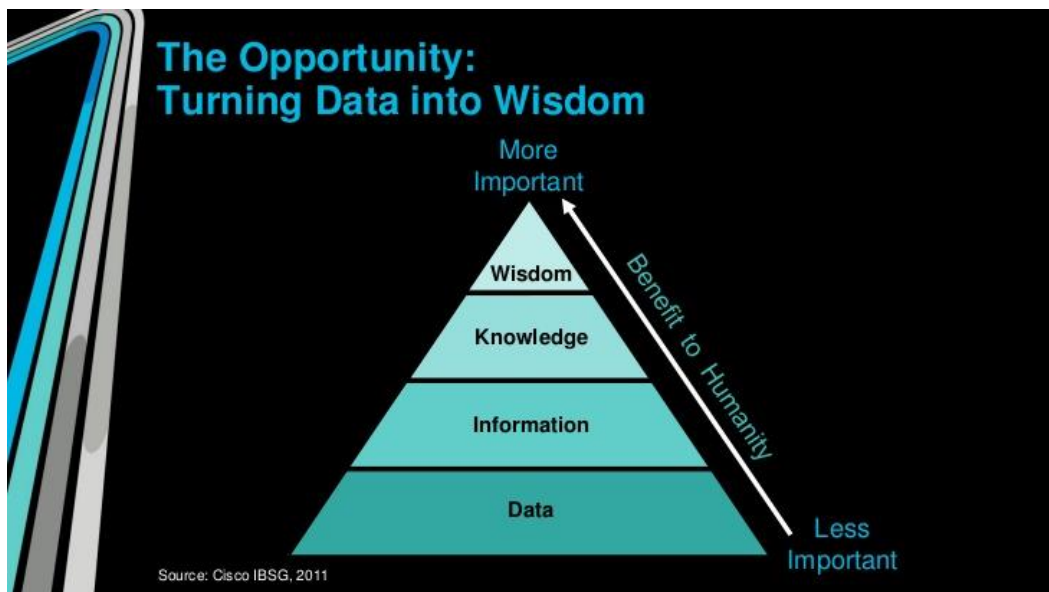

Fig. 1. Transformation of data into wisdom  
(Cisco IBSG, 2011).

**The issue current state.** The mentioned problems are not brought up in Ukraine /8/. The researchers are interested in the knowledge (information etc.) transfer and want students to recall it at the necessary moment. Only enthusiasts teach the art of thinking.

What is knowledge? According to the definition “knowledge is the ordered aggregate of new characteristics of a subject and the world and their interrelations represented in the form of the certain metatext. The transfer of separate images into the systematized valid form, keeping of everything that can be saved, transferred and developed is done in the knowledge. The problem of knowledge, its structure, appearance and specific cognition and understanding and birth of the new knowledge (creativity) is philosophical, methodological, natural, scientific, humanitarian and applied. It is one of the most complicated problems”. /10/. The knowledge scheme according to the Cisco is given in the fig. 1.

The scheme is interesting, but we think that it is hardly possible to show its multidimensional nature by two-dimensional means. Our scheme will be given below. We will use the two following postulates to find the problem solution. The first postulate is as follows: **the farther we will go, the more exact the forecast will be.**

And the **second postulate** was stated by the remarkable Ukrainian researcher G.S. Tesler in his book “New Cybernetics” /9/: “There are two main results in the work of Gödel: the impossibility of mathematical proof of consistency for any rather large system (pedagogic suits the definition) that includes arithmetic in the frameworks of the system and existence of the principle limitation of the axiomatic approach. Not a single solution of the arithmetic system can make it complete. Although the results are proved for arithmetic, they have the common methodological nature and can be applied to the systems of any nature” /8/. **Both contradictions can be solved only on the basis of meta-theories and meta-approach.** We will use it to solve pedagogic tasks. In this case pedagogic is a meta-science.

**Metapedagogic.** There are two different (many consider them contradictory) cognition fields –scientific proper and metascientific. The paper /12/ proves that the differentiation must be applied to pedagogic too.

The scientific cognition proper is aimed at the world which is outside relative to science, and the self-knowledge is directed inside the science. Their interaction allows existing and developing of the science. Thus, the science can be represented as the system that includes two interacting sub-systems: the science proper and the metascience. The scheme is shown at the fig. 2.

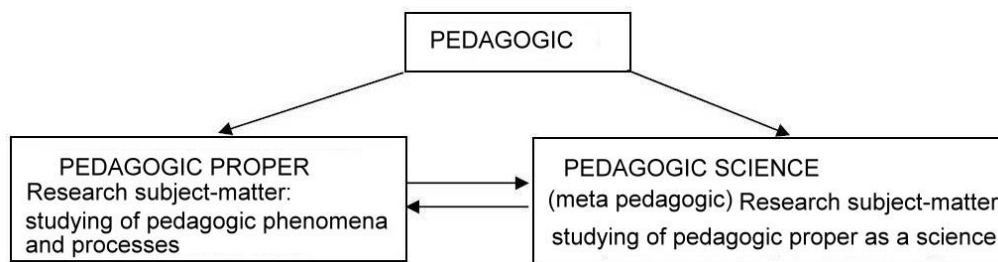

Fig. 2. Pedagogic and metapedagogic

**Knowledge hierarchy** What is knowledge? The definition of knowledge was given earlier /8/.

**We propose the following hypothesis of the knowledge hierarchy: information – knowledge – metaknowledge.** The common non-structuralized information is the principle from which the knowledge (let us call it applied or something which is necessary for the everyday life) is formed. The knowledge from the capital P is the one that helps us to find the way to the eternity. It is the finding of the metaknowledge that is historically given to the mankind through the teachers and prophets. The knowledge was obtained by people in different states and it is being studied thoroughly through the insight. Jakob Böhme, the shoemaker, William Blake, the semiliterate engraver, the illiterate prophets Ezekiel and John the Apostle with his horrible Apocalypse and uneducated K. Tsiolkowski, Edgar Cayce and John Worrell Keely had the insights /11/. It is the way all outstanding people cognized the world. V.I. Vernadski, whose portrait is on the wall of the DonSTU Rector’s office, said: “The space models the Earth image ...”

**The hypothesis of the scheme of consciousness and knowledge exchange in pedagogic.** The DonSTU Vice-Rector on International Affairs Prof. I. Navka says: “Everything which is new comes to world as the heresy and leaves the world as the dogma”. We would like to discuss the scheme of the consciousness hypothesis in the paper. It is given in details in /14/.

Fig. 3 illustrates the place pedagogic occupies in the general structure of science as metascience.

We keep to the consciousness model and offer its scheme of functioning in the pedagogic process. Every teacher and student is the

model and exchanges the information (knowledge, wisdom) in different particle and wave ranges.

It can be sound vibrations (voice), a video range (video), field exchange (bio and thermal). According to the information scheme of John von Neumann a teacher (as well as a student) is a generator that codes and decodes the messages that are transferred from one to another in the form of the words that are the meaning semantic model. All these concepts are multidimensional and 11D according to the string theory.

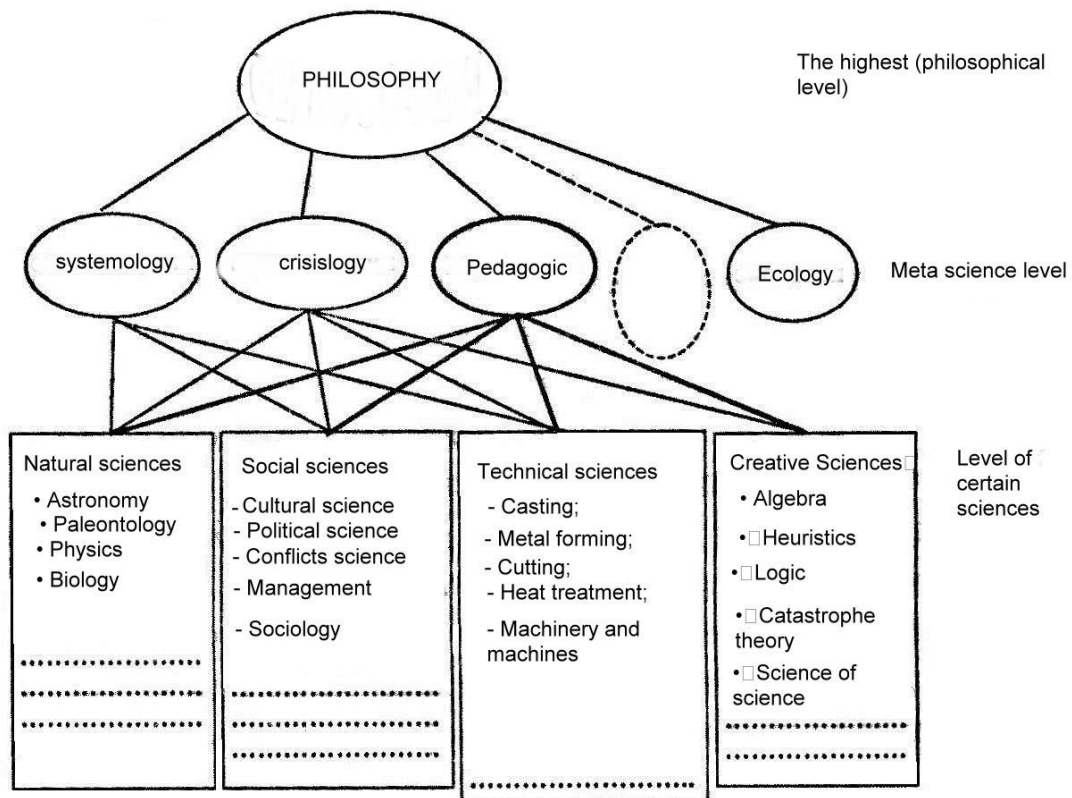

Fig. 3 The place pedagogic occupies in the science general structure.

**The future forgotten pedagogic.** There is a saying “All that is new is the well forgotten old”. We think that it can be applied to pedagogic too. All the achievements of pedagogic are related to the application of the so-called psycho-physical channel. The best teachers are said to have the God-given talent. They can use both information technologies and psycho-physical channels that connect them with the noosphere (a data base or God, according to Prof. Puck). This area is not being studied though it is a

pedagogic subject-matter. It was written about several times but the things are still where they started. The knowledge each individual has is limited and he can not know everything. According to Arthur Schopenhauer there is a difference between a genius and talent. “The talent shoots the targets that people see, and the genius shoots the targets that people do not”. These are teachers having the God-given talent. We know them but can not repeat the experience. We can only see the results of their work as the knowledge and methods are inexpressible and can be understood by contemplation and coming to the resonance with these high vibrations. The hypothesis of the transfer is given in the fig. 6. It completely corresponds to the energy-and-information pedagogic that is described at the work of the Ukrainian teacher I.N. Podlasi /15/.

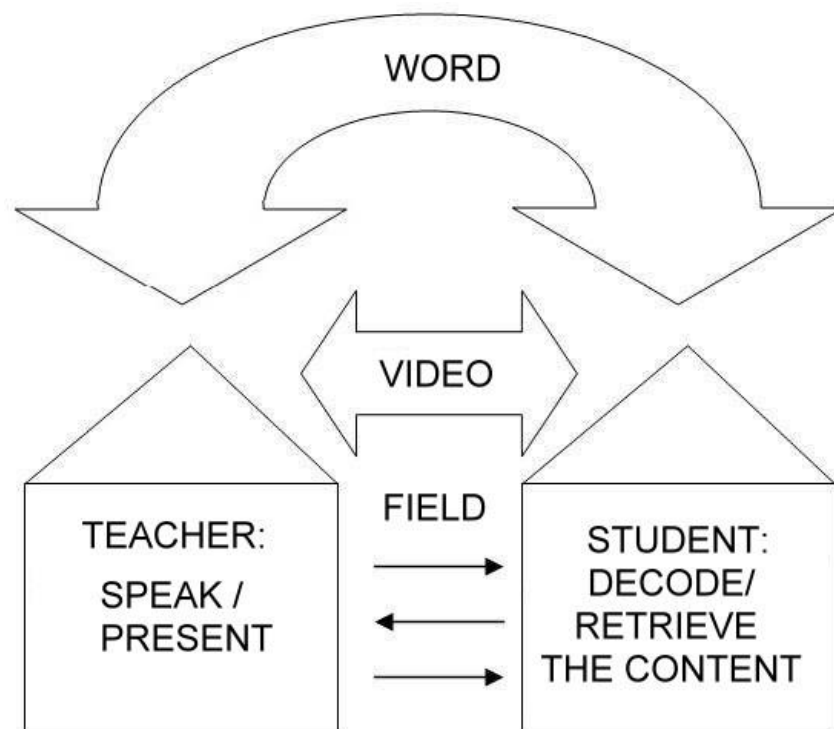

Fig. 4. The scheme of interaction between a teacher/student in the energy-and-information training process.

**Conclusions:** The hypothesis of communication (the knowledge transfer) of consciousness with the other one, which is crucially important for creation of new generation distant courses for electrical engineering students, is presented in the paper. The pedagogic aim is stated. The ways to solve it with the help of Gödel's theorem and meta-pedagogic idea



development are shown. The modern pedagogic thought says that education has the only goal – to form the state national elite /16/ but not to transfer knowledge and skills in maximum, which is quite important too, but only at a low level. It is high time to enter the meta-level of the problem understanding. There is no technocracy at the level. The technocracy behaves towards a man and the Earth as the representative of black magic as its application in order to control people and wealth is the characteristics of the black magic. Isn't the mankind doing the same and isn't pedagogic serving the dark forces? Isn't it the time for the pedagogic to come back to its highest idea of searching the truth? When the society rises to the idea it will deserve the great future. There is one more aspect of responsibility. When we hear the words that scientific knowledge is always the good we recollect a sarcastic remark of Nietzsche (1844-1900): “Where the tree of knowledge is there always is paradise- the oldest and newest snakes say this”. That is the knowledge is not always the good. According to the Scripture the one who is able to distinguish one from another will have something and the others will lose it.

#### References:

1. S.K. Borisov, N.N. Yakimova. Consciousness the Space Creative Force. The Delphis journal <http://www.delphis.ru/journal/article/soznanie-kak-tvoryashchaya-sila-kosmosa/>
2. P.V. Stephanenkp. Methodological Aspect of Distant Learning Quality Assurance // Proceedings of DonNTU. Series: Pedagogic, Psychology and Sociology, № 10, 2011. – p. 209-214.
3. P.F. Roerich. Spiritual Biography Practice. – N.: ICP “Lasarev and O” 1994. – 201 p.: <http://www.roerich.com/zip/belikov.zip>
4. Agni Yoga Sides. 1955. – N.: Algim, 2011. - 704 p.: [http://www.roerich.com/zip3/grani\\_55.zip](http://www.roerich.com/zip3/grani_55.zip)
5. L.M. Gindilis. Consciousness and its Role in the Universe: Scientific and Philosophical and Meta-Scientific Aspects // the proceedings of the X inter-disciplinary scientific conference “Ethics and the Future Science” – Consciousness as the Space Creative Force. – M.: Delphis, 2011. – p. 5-13.

6. Theory and Practice of Distant Learning. Students' textbook / E.S. Polat, M.Y. Bukharkina, M. V. Moiseeva; edited by E.S. Polat. – M.: The Publishing Centre Academia, 2004. - 416 p.
7. E. P. Blavatskaya. What the Truth Is.: <http://www.theosophy.ru/lib/hpb-ist.htm>
8. S. U. Goncharenko. Pedagogic Research: Methodological Recommendations for Young Researchers. Kiev-Vinnitsa: DOV "Vinnitsa", 2008. – 278 p.
9. Oriflamma newsletter. : <http://www.roerich.com>
10. D.I. Shapiro. The Virtual Reality and Neuro-computing. – M.: KAJI-Image-Lab, 2008. – 54-55.
11. G.S. Tesler. New Cybernetics. – K.: Logos, 2006. – 2004. – p. 57-58.
12. N.A. Vershinina. History of Pedagogic as a Science of Science Discipline.: [ftp://lib.herzen.spb.ru/text/vershinina\\_8\\_30\\_56\\_68.pdf](ftp://lib.herzen.spb.ru/text/vershinina_8_30_56_68.pdf)
13. L.N. Melnikov. The Virtual Reality and the Space Consciousness // Delphis, №2 (46), 2006. – P.111-112.
14. S.G. Dzhura. On the Issue of Multidimensional Consciousness // Proceedings of the X international inter-disciplinary conference "Ethics and the Future Science" – Consciousness as the Space Creative Force. – M.: Delphis, 2011. - p. 30-39.
15. I.P. Podlasy. Energy and Information Pedagogic. – M.: Data Square, 2010. - 424 p.
16. A.G. Romanovski. The Spiritual Element as the Main Factor of Forming of the National Humanitarian and Engineering Elite // Theory and Practice of Social System Control: Philosophy, Psychology, Pedagogic and Sociology, №2, 2009. – p. 15-20.

#### **4.2. Distance education of the future: approaches made through the retrospective analysis of the philosophical thought**

O. M. Spirin, S.G. Dzhura

*The analysis of synchronistical and diachronic links among different pedagogic ideas, education systems and models that existed in different*

*times was made in order to pick out the best one for distant learning and implementation into the training programs of artificial intelligence. .*

Nowadays the concept of education is used in different sciences and has different sense loads. It is used in both senses- wide and narrow – in pedagogic. The wide sense implies purposeful training and bringing up process carried out in the interests of the person, the society and the state, and it is identified with such pedagogic concept as training in its narrow sense.

We think that education has some super-mission and it is to be found in the history of all the nations. Many sciences can be of help, especially philosophy. Nowadays scientists all over the world are coming to the thought that the noospheric civilization can fulfill some evolution mission. In the noospheric education this mission is marked as man's improvement, his refining and transition from the wild state through the civilization to synthesis finding. The thesis will be revealed below with the reference indication. Now we would like to discuss the hypothesis that education as any other creative work needs tasks to be stated. It is, from our point of view, equivalent to the optimization task. The statement of the latter is the purposeful function and limitation. Life expectancy, material possibilities, etc. can be limitations for a man. Getting of maximum creature comforts (that many of the people think is the purpose) can be the purposeful function. L.N. Tolstoy in his work "Education Fruits" says the statement is wrong. From our point of view a perfect man is the purpose. What it means is a subject matter of a separate talk or even dissertation. We will accept it as a hypothesis. Culture in this aspect is the virtual data base that shows the deadlocks of the mankind's development. Many areas are not developed yet. Well-known things are accumulated in the form of knowledge and are reflected in information technologies. Some areas, their technologies and what is to be expected will be discussed in a separate chapter.

**Pedagogic thought in the epoch of the Antiquity.** The antique Greeks made an outstanding contribution to the theory of pedagogic that was developing in the frameworks of philosophy. All ancient Greek scientists discussed the issues of education in their works. They were the founders of the humanistic pedagogic tradition /1/.

The first teacher-philosophers were sophists (Hippias, Zenon, Cleobulus, and Protagoras etc.) and Socrates (469-399 BC).

The sophists declared man “all thing measurement” and made the first ever attempt to subordinate education and bringing up tasks to the needs of the particular person and make them independent on his needs and interests. The main goal of education was considered achievement of the personal success. They admitted breaking of age-old principles of piety and disapproving of the social norms /2/.

Moral norm convention that the sophists propagated caused active protest of their contemporaries. Their ex-follower Socrates was one of the irreconcilable opponents on the issue. He thought a man as a rational and clever being to be the measure of all things. According to Socrates the basic ability of the man is thinking and intellect. Ignorance causes moral evil and therefore knowledge is the source of moral perfection. Socrates did not deviate from sophistic rationalism as to pedagogic problem statement and solving, but contrasted the sophistic school practicalness with the idea of virtue independent meaning and objectiveness of moral norms that, according to him, was the necessary condition of bringing up of a free citizen of the democratic society /1/.

Socrates’ pupil Plato (427-347 BC) made a great contribution into the development of the philosophical and pedagogic idea. He thought the learning and bringing up was aimed at helping a man’s soul to recollect everything it touched in the world of ideas and bring every individual closer to the ideal. He developed the ideal state theory and proposed the corresponding system of education. He integrated some specific features of Athenian and Spartan upbringing that met his methodological aims. The system had a new peculiarity in the form of social upbringing starting when a child was three and two stages of super-obligatory education (for 20-30 year-olds and 30-35 year-olds) for the most talented pupils.

Plato’s pupil Aristotle (384-322 BC) played the most important role in the history of ancient philosophy and pedagogic. He admitted the world of things and that of ideas but did not separate them. He made the first ever attempt to conclude the goals and tasks of bringing up on the basis of his own understanding of the man’s nature. According to him three sides of the man’s soul (plant, animal and rational) corresponded to three aspects of upbringing: physical, moral and intelligent. The nature tied firmly the three soul types and therefore a teacher was to follow the nature and tie the upbringing aspects that corresponded to them. Aristotle summarized the

mankind's historic practice and his own observations and introduced an age grading dividing the life of a growing child into three stages that corresponded to the characteristics of its development; from its birth till the age of 7, from the age of 7 till the age of 14, and from the age of 14 till the age of 21. He also gave his recommendations as to bringing up and educating of the child in every period of the life /2/.

Aristotle as other great ancient scientists was ahead of his time. It was nonrandomness that his works in logic, physics, meta-physics and other branches of science were the main European manuals three centuries later and in the medieval period.

Besides, other well-known ancient scientists, Democritus (460-371 BC) and Xenophontis (450-355 BC) being among them, made a remarkable contribution into the development of the education theory and practice /1/.

In the III century BC the ancient Greek culture and education traditions conquered Rome that had been the leading military state with a low level of its cultural development. Gomer's "Odyssey" translated into Latin by a freedman called Livius Andronicus had been the main tutorial at Roman schools during two centuries. Due to the fact the Romans learnt traditions and intellectual wealth of Ancient Hellada. There were some peculiarities of the education process and specific muse cups which we will correlate with the Greek patterns studied before.

The Roman education system that had been formed by I century AC was an independent cultural tradition for the following periods. It was mainly the merit of the "father of Roman scholarship" Marcus Terentius Varro that defined the contents of education (7 free arts) and a famous Roman philosopher Marcus Tullius Cicerō. Cicero developed the ideas of the sophists and introduced the concept of "humanism" which he associated with the pattern of a decent life. He formed the cultural ideal of a free person that combined phylosphical scholarship (as a means of individual perfection) and rhetorical scholarship (as a means of social influence) and stated the further development of antique pedagogic /1/.

The Roman pedagogue-humanist Quintilianus (35-96) is a famous figure in the history of education. Like Greek stoic Chrisippos he reasoned the necessity of child's correct upbringing from the day of its birth and emphasized the determining role of its pedagogue's personality that was to

be a moral person, to love children and to have the necessary skills. Quintilianus called on cultivating kindness and philanthropy, and unlike education practice stereotypes he disapproved punishment that traumatized a child's soul and caused hatred towards people around. Quintilianus developed new ways of cultivating love for studying through praise, encouragement and reward, and games and rest that were to occupy a considerable part of education process. He formed the principle of an individual approach to every pupil with taking into account his abilities and inclinations. He insisted that every child had natural abilities of getting full-grown education. It is not a surprise that during the last years of the Roman Republic and during the principate and the empire not only boys but also girls who were the children of both free citizens and slaves got decent education at special schools- paidagogeions.

Thus, the Ancient Rome was the first to accept that all people despite their gender and social status had the "kind nature" which was to be revealed and developed through the education that was to be organized correctly. The humanistic principle of generally accessible education was formed and the necessary steps for its implementation were made that time. Diachronic links among education schools of different countries and states were formed in the ancient period. The development of engineering technologies raised the role of synchronic links, which are synchronous to the processes taking place in different countries. Knowledge was being accumulated at this period of time /1/.

**Knowledge hierarchy.** What is the knowledge? According to the definition "Knowledge is an ordered scope of new characteristics of a subject and the world and their interrelations represented in the form of a particular meta-text. The knowledge transfers separate images into the systematized meaningful form and keeps everything that can be saved, transferred and developed. **The problem of knowledge, the structure, appearance and the specific nature of its cognition and understanding is a philosophical, methodological, scientific, humanistic and applied one and can be considered one of the most complicated problems**" /3/. **We would like to propose the knowledge hierarchy hypothesis: information-knowledge- meta-knowledge.** The ordinary non-structuralized information is the fundamental principle out of which the knowledge is formed (let us call it the applied one that is necessary for the

everyday life and earning for the daily bread). The knowledge from the capital P is the one that gives us the chance to find the way to the Eternity. It is getting of the meta-knowledge that is historically given to the mankind through prophets and Teachers. The knowledge was obtained through insights that are being studied thoroughly. Jakob Böhme, a shoemaker, William Blake, a semiliterate engraver, uneducated prophets Ezekiel and John the Apostle (with his terrible the Apocalypse), K. Tsiolkowski that had no education at all, Edgar Cayce and John Keely had such insights /4/. It is the way of cognition all great people went through including the famous power-engineering specialist Nikola Tesla. V.I. Vernadski said: “The space forms the Earth image...”

**Metaenergetics.** We wrote about N. Tesla’s phenomenon in the previous proceedings of the Electrical Engineering Faculty /5, 6/. We also wrote about John Keely /7/ that was a mathematical genius and had the unique principle that made it possible to control the energy of the spatial ether. He succeeded in bringing it down to the Earth being not initiated to the final Mysteries. Although Keely’s devices operated due to the ether power, his own psychic energy was the trigger that activated it. **The result might be considered the prototype of the remote ability of the mankind to get the energy not from the Earth interior but from the Space depth.** N. Tesla and J. Keely can be called the Future Messengers. An ordinary person might want to know why it is impossible to be repeated nowadays. The answer is the following: “The representatives of the modern fifth race deepened themselves to the substance very much and were not allowed using the spiritual spatial energy (with a commercial purpose!) as it might threaten their lives and the life of the planet as its power had no boundaries both in creating and destroying” /8/. N. Tesla drove the ether by another method, and got the energy for his engines from it. The issue is very complicated and whether the mankind will transfer from ordinary exegetics to metaenergetics depends on its solving. When we say metaenergetics we mean non-fuel ecologically friendly energetics of the future. Its existence is possible as technology ideas had been taken from science fiction and many of them were implemented (flight to the Moon, robots, submarines, the Internet etc.).

**The role of the EEF and DonNTU in metaknowledge getting.** We spoke about it at the beginning of the paper; however it was especially

evident in 2008 when one of the representatives of the EEF was working at creation of the Internet resource devoted to understanding of the metaknowledge. First the material was accumulated, and then it was discussed at forums and more than 20 related projects. The history and explanation of it is given in the paper /9/. In 1991 the project Oriflamma <http://roerich.com/> on creation of the e-library on the synthesis of science, religion and philosophy appeared. In 1997 it was recognized in the I-net and got Ukrainian and international (2008) rewards /10/ that proves the recognition of understanding of the metaknowledge concept. In 2008 international experts called the project the best in the world as to the synthesis of science, religion and philosophy. The project got the diploma in the nomination of “Roerich’s Heritage Preserving”. The Director of the Hermitage Mr. Piotrovski /11/ who is the chairperson of the club of St. Petersburg’s residents handed in the diploma to the representative of the EEF at the State Hermitage. All the staff of DonNTU deserved the reward which is the motivation for continuation of the work. The paper is the contribution into understanding of the e-library ideas.

**The mankind’s knowledge.** The Oriflamma project is implementation of the idea of St. Petersburg researchers. /12/: “Knowledge, from the point of view of a separate person, is the information on possible results of the future processes in which the person is going to take part, on possible implementation of favourable or unfavourable results, on the methods and ways of influence on the possibility... Thus there are a great number of elements of knowledge of separate people that can be of help for all the people or many of them. The knowledge can be called the mankind’s one. As all the people are interested in it they have to be organized in order to solve three tasks.

1. To provide maximal (free) access to the knowledge for all the people. Such means as books (libraries), newspapers, the radio, TV, leaflets, the Internet, the Synergonet increase the survival of some people and all the mankind as it is a complicated self-organizing system.

Any structure formed by people and making financial, and information obstacles for spreading the knowledge worsens the future of the mankind and a separate quantum and is criminal. The statement can be the criterion of the criminality and the totalitarian nature of regimes irrespective of their opinion on their own democratic character. One of the main or even the



main criteria of the power criminality is not only the number of people killed by the power but the amount of the mankind's knowledge that was not brought to all the society members' notice free.

2. To provide decent living to the people who participate in getting and spreading of the knowledge necessary to all the mankind. It concerns the material and information living of researchers, pedagogues, journalists, culture representatives and religious figures". We think that the matter is in the metaknowledge. It was implemented in the project Oriflamma fulfilled and supported by the EEF of DonNTU.

**The metaknowledge examples.** We would like to cite the statements on the future of the energetic and the society implemented in other being spaces "...We do not have plants, machines and factories. The spirit device has substituted them. We have all our people need. The Earth gives birth to everything that can please our bodies. We have to work much and hard. It is the physical labour to support our physical health. But the main labour area is the thought field and fine energy application. Man controls the nature forces and the elements. The forces are powerful and inexhaustible. The space gives all the mankind needs in the sense of **energy**. How hard do you work to get any type of the working energy? Fiery energy is at the man's service and we apply and use it with the help of man's microspace device. **We are close to fulfillment of the great task – to arm the man with the help of no device.** The Life Fiery Doctrine is single for all the populated worlds and the Highest Knowledge fruits are widely used here. I inform you, the earthlings, about it for you to know the main field of the evolution and life forms implemented here and to make them achieved at your Earth..." /13/. As far as science is concerned "ours differs greatly from yours as it is based on the secret knowledge of space laws which is common for all the worlds. Your official science is very young and is just approaching the understanding of the hidden forces of the nature and mysteries of the man's microspace. It denies much because of its ignorance and self-importance. That is why it is one-sided. We have the real and practical knowledge, which is combined with the life secret doctrine as a whole; and the space mysteries and those of fine energies serve us in the current life" /13/. The conclusion is as follows: "It is the indisputable knowledge of spirit but not dreams, fantasies and groundless imagination that will lead us to the depths of the space to distant stars. You should think

over the man's space way. You will not be able to understand it if you do not learn the life in the distant worlds that are given to you as the prototype of your future achievements as the leading force and the goal ..."/13/.

**Interim conclusions.** The fragments of the metaknowledge we mentioned are to be decoded for us to understand how J. Keely's engines worked and how N. Tesla transferred energy without any losses and planned to create non-fuel and ecologically friendly energy supply for the Earth. Even if the facts seem inconceivable we should work at them. The main thing is for the mankind to deserve the knowledge. Ethics is the main criterion or safety engineering in case of communicating with the knowledge. Therefore the task is as follows: **to develop and understand the universe ethic algorithms as "the knowledge is both obligation and responsibility.** The responsibility for getting the knowledge is huge. It is given not in vain and not for the personal pleasure, but for its severe **application** in life" /13/. Landau meant it when he spoke about "natural science, uncommon science and supernatural science". We think that ethic algorithms belong to the supernatural science.

**Ethic algorithms.** Algorithm development genesis takes place while the space laws are understood. The laws are expressed in genetic algorithms, neuro-algorithms and the computer as the understandable algorithm of the man's left-sided thinking. But this hasn't given a good result so far as the amount of the knowledge that is learnt badly is growing. What shall we do for the knowledge to work for the evolution only? How to protect the knowledge from being used for the evil? The answer is as follows: we should learn from the nature. There is a famous saying that everything which is new is the well-forgotten old. We do not discover anything new in the issue. We only open the old slightly. We think the algorithms exist. They were used in ancient books and esoteric texts. Let us speak about the Bible (or the Quran or the Veda). They are coded and the reader understands as much as his inner state allows doing it. The one who knows the keys (they are thought to be 7 – mathematical, astrological etc.) understands them. According to the nature laws if the reader improves himself he understands more and more even if he reads one and the same thing. The one who does not change himself makes no headway until he finds the solution. Of course, there are some exceptions, black magicians,

for example. The nature allows them lawlessness for some time but sooner or later it puts everything into place. Thus, we open the ethic algorithms (the nature cryptography) slightly. While reading cryptography books we come to the conclusion that the universe controls the man without breaking his will and teaches him to move towards the evolution. Here is an example taken from the Sides of Agni Yoga/13/: “The Light coming is preceded by the intense darkness. When the darkness comes to its zenith the forecast will become a reality. Thus you have the sign to judge upon. Everybody will bring something personal that depends upon the consciousness size to the construction of the Future Temple. For the new to be created the old is to leave. The old should make a sacrifice to the new. Many are suffering and will do it. But the evolution does not take into account either victims or sufferings. The entire species of plants and animals are destroyed in the name of the final goal. Races and civilizations die to give the place to new ones. Luxury of Babilon, knowledge of Egypt, power of Rome, culture of Greece was replaced by new forms of the state life and buried the past under their debris. The nature is generous-destroying some forms it immediately creates new ones to replace them. The life of a person and his personal interests mean nothing in the flow. According to the life law everything which is alive clutches at the life but dies in the endless form change but preserves the essence that finds a new more perfect form under the changes. The form is nothing but the essence can not be destroyed. The experience that the form gains enriches the endless seed of the energy grain, and improves, and transforms the essence that does not die. The life essence potential in its physical form, which is nothing, is also inexhaustible. The eternal and immortal become apparent in the mortal to show their essence in the evolution endless process”.

**Ethic algorithm essence.** According to V.V. Puck the main problem of the information (or post-industrial) society is the absence of the criterion of the information quality. But the culture knows what is useful for the evolution and what is not. How can we distinguish one form another when the evil dresses itself up as the good? We need the ethic algorithms that have existed in the nature to do it. We often think about the visible universe and forget about its invisible part which is registered by devices that widen our knowledge. We can not be objective as our knowledge is very limited. We know only about 5% of the

substance the universe consists of. 95% of the universe mass is collapsars the composition of which we do not know at all. G.I. Tesler has a hypothesis that they consist of the information /14/. Here is a real synthesis. V.V Puck said: “Ancient knowledge is to be transformed into scientific formulae”.

**Distant learning at the new stage.** In the basis of the education energy-and-information paradigm /15/ we can drive to the conclusion that learning process is to be as close to a student as possible. The Skype technology when both a teacher and a student see each other on-line is the most convenient now. But the energy of one practically does not meet the energy of the other. There is only a video and sound contact which is good but not enough. In this case the auras of both do not touch each other. It is a well-known fact that the atmosphere of the laboratory a researcher works at is the catalyst of his research activity. The teacher’s energy field might be added to on-line broadcast. The effort might look poor as the machine is only a prop for the man. The man is to discover its own inner reserves 95% of which have not been used so far /16/. The machine evolution significance is in ability to show the man what possibilities he might have in the future: thought and image broadcasting (camera and TV), man’s aura investigation (its symbol is shown on the example of the toy Russian dolls). We can also speak about the aura of premises and people. When we come into it everything goes by itself and understanding of the previously impossible things takes place in the team and the room. The ordinary knowledge (horizontal, for the life earning) can be broadcast on a distance. To understand something which is deeper we need to make our own way to the teacher. There is an oriental saying: “The teacher comes when the student is ready”. It is great luck for both. The Sides says /13/: “The intimacy with the teacher is to be looked for in the spirit. It is accessible in the spirit. You can be elevated by the spirit with your body being fined. If the spirit is high it elevates its coats as a balloon raises a basket with its ballast. Spiritualization of physical, astral, and mental matter made by the spirit mental fire takes place. The evolution goal is to spiritualize the Earth and its physical spheres and transform the rude into the spiritual and fiery”. It is a super task, the future distant learning. The traditional approach to education is in getting a book, a leaflet, or a film. It is not a problem in the information epoch as the knowledge is accessible (open and

noospheric libraries). But there is a problem in the knowledge extraction. The real (vertical) knowledge is usually coded. It helps laymen. The Bible has seven keys without which it is impossible to understand it totally. When a recipient gets the knowledge because of some reasons and uses it in super selfish ends it is called the black magic. The space laws are legal on the Earth and behind its limits and not only in this but in future lives. This means that punishment will take place anyway. The birth of monsters is explained by it. It is not only the fault of parents (sometimes the monsters are born from decent parents). The future of distant learning has two versions. The first is the traditional one – the inner improvement (computers, communications, and software). The second one is oriental – self-improvement and the teacher will come in time to him who knocks at. 13 illustrates the idea: “The wish to get the certain knowledge predetermines its getting. It also concerns any strong and legal wish. It becomes a reality very quickly. We help in everything that concerns the common good”.

**Conclusions.** The innovative approach of the energy and information concept of education development is a decisive one /15/. Different education technologies (distant learning in particular) can be developed in the frameworks of the concept. The mankind will be faced with understanding of ethic algorithms of the universe which are paid attention to in the paper. We might take a technocratic lesson (of inner perfection) at the new stage of the mankind’s development and come back to the life simplicity when there is no need in machinery. Then we will not need the distant learning as teacher’s coming to a student might happen in any space of the being. “The phenomenon simplicity is not accessible for people as the life great laws are too simple for the people to accept them without wandering around. All which is great is simple. As far as the simplicity is not typical for people the great is difficult. Communication in the spirit and by a thought is easy and accessible. But who believes in it? How many years did we need to get into contact with Guru? Thinking wheels rotate slowly as there is no simplicity...” /13/ We will learn **the “new” method of knowledge getting to which the evolution is preparing us**: “How big is the amount of interesting findings the man faces! The entire world is open for learning but not through the brain. The communication goes through the same channel through the heart. The heart grows and is deep in

the subtle work. We should develop feelings. The knowledge comes to their centres and reaches the consciousness. The spirit knows much. The knowledge of the spirit and the feelings are inseparable. Both mean the direct knowledge without interference of the brain. When the consciousness is concentrated on getting the direct knowledge it gets it if the brain is not allowed to interfere into the process. The brain in this case acts as an accountant of the facts that come into the consciousness. But the knowledge getting itself takes place without it. The knowledge of spirit and feeling is a new method of getting knowledge and obtaining information for the subtle consciousness. /13/ We will not need ordinary libraries as we will use the natural ones as all the knowledge is in the noosphere and can be got from there directly. It will be a new stage of the mankind's development. Esoteric sources which are accessible for people show how to get there.

### **Upbringing, school and pedagogic thought in the Middle Ages and Renaissance.**

Renaissance is a very important stage in the history of the European civilization and education in particular. It made its great contribution into development of pedagogic and its practice. It is the epoch of founding of the first universities /1/.

Renaissance humanists place man in the centre of their world outlook and paid much attention to education associating it with the civilization moral and social progress. This explains the interest they had in pedagogic and founding of schools (Vittorino da Feltre and Paolo Veronese) and numerous scientific works and fiction (Vergerio, Michel de Montaigne, Thomas More, François Rabelais etc.). Pedagogic heritage of the ancient culture was the main ideological source of humanistic pedagogic. The humanists accepted both classical (Greek and Roman) culture with its social motif, ideas of patriotism, free harmonic development and civil service and late antique doctrines with the interest to the personality and moral improvement. Early Christian works influenced humanistic pedagogic. Thus the synthesis of two cultural traditions – the antique and the medieval - takes place at this stage of the European civilization development. It caused new Renaissance cultural point of view that is clearly seen in the pedagogic of that time period /2/.

The main pedagogic and didactic principles for the humanists-pedagogues were affordable, voluntary and conscious learning, links with the nature and life (Michel de Montaigne, L.B. Alberti), self-learning and labour education (Alberti, Vergerio, More). Children's self-government, creation of the special atmosphere which turns learning into a fascinating process was used in school practice. To achieve the goal excursions, cognitive games, lessons in the nature and active rest forms such as horse riding, walks; swimming, hunting, dancing and outdoor games were organized.

The pedagogic thought of Renaissance was much ahead of the school practice in its traditional medieval form. The accumulated pedagogic practice, theoretical heritage of pedagogues and philosophers made their trace in history and stimulated further humanistic education traditions for the following epochs and is the main cultural source for the innovative humanistic search nowadays.

In 476 the Roman Empire was weakened by inner contradictions and collapsed under pressure from German tribes. A new stage of historical and cultural development of Western Europe called the medieval period (V-XVI centuries) started. The Christian world outlook and way of life and the Roman ideal of the statehood were the leading cultural paradigms. At the same time the "pagan" antique traditions and life opinions were oppressed and reconsidered.

The Roman Empire Christian religion famous as Catholicism (1054) was the main force that influenced the entire historical and cultural process of medieval Europe. Education and upbringing developed according to its principles. It was reflected in the new view of man. He was declared the "creation crown" formed by God's image and likeness. Christianity singled out two man's origins – a body and a soul. According to the medieval theologians the true essence of a human life was in unconditional obedience of the bodily origin to the spiritual one. The image of a spiritual ascetic replaced a thoroughly developed handsome athlete /1/.

The concept of "I", the inner world was not popular in the antique period. Christianity stimulated attention paid to the intimate part of the man's soul. The inner life of the person became the studying subject-matter and was of the paramount religious value. We are interested in

authoritarian and scholastic medieval education because it taught the virtue, God understanding, inner freedom of the person and gave pedagogic clear moral key points based on Christian moral eternal values. For better understanding of theoretical fundamentals of the medieval Christian pedagogic it is desirable that we know the views of some famous educators such as Aurelius Augustinus (354-430), Alcuinus (735-804), Thomas Aquinas (1225/26-1274). To discuss new types of medieval schools we need to know specific features of church and secular schools.

The education space of the medieval period was occupied by schools that were opened and sponsored by church (monastery, parochial and cathedral). The monastery and cathedral schools were divided into the inner (for the future priests) and outer (for laypeople's children). The inner schools offered wider education and taught the so called trivium (grammar, dialectics and rhetoric) and in some of them quadrium (arithmetic, geometry, astronomy and music). "Trivium" and "quadrium" made up "seven free arts" that were taught in Latin in all countries of the Western Europe.

The main population in the medieval period did not get school education. To involve children into productive labour and give them a profession the system of trade schooling was organized. Later on to meet the demands of traders city schools (magistrate, shop and guild) were opened. They taught in the native tongue and teaching methods were practice oriented /2/.

In the second half of the medieval period the trading contacts were wide. The crusades (X-XIII) stimulated acquaintance with Arabic culture. The information in mathematics, astronomy, geography, medicine and other sciences was accumulated and it caused deepening of the knowledge about the environment and the world as a whole. The church schools ignored new knowledge (why?). Therefore nondenominational unions of scientists were formed. They opened their education institutions (medical school in Salerno, law schools in Bologna and Padova).

In the XII century Bologna (Italy), Paris (France), Oxford and Cambridge (England) universities were established. They were voluntary associations of academics of different specialties and students. The universities were independent of the church and secular authority.



The structure of a classical university, contents of education and methods of teaching as well as the contribution they made into the development of European science and culture should be mentioned /1/.

Medieval universities consisted of 4 faculties: three fundamental (medical, law and theological) and one preparatory (art). “Seven free arts” were taught at the preparatory faculty during 6-7 years and then the graduates got a degree of “Master in Arts” and were given a chance to continue their education at one of the three fundamental faculties. They studied for another 5-6 years there and got the degree of “Doctor of Science”. Lectures and disputes were the main forms of classes at the universities. The theologians tried to balance science and religion and adjust the secular knowledge to the authority of Scripture. Useless scholastic arguments had positive meaning at first sight. They developed abstract thinking and ability to select necessary arguments and build proofs. That stimulated the science development in the epoch of Renaissance (XIV-XVI centuries).

The first universities were libraries. An academic took a book and read it to his students as there were not enough copies of the books and it was dangerous to lend the only copy to a first comer. It is not a problem with the modern technologies now. The responsibility for the given knowledge was the important pedagogic point. The knowledge was thought to be a double-edged weapon that could serve the mankind or be directed against it. Thus the knowledge was to be given to the person who deserved it. That time a teacher defined it. It is a problem for the modern information technologies. If we are able to implement it in the form of the described ethic algorithms, it will be a scientific breakthrough. Now we are just setting the problem as uncontrolled spread of knowledge does not lead the mankind to the goal. More than that, the mankind might stop its existence (because of the nuclear and other modern weapons)/1/.

**Upbringing, school and pedagogic thought in Ancient Russia in XI-XVII centuries (we also speak about the Ukrainian pedagogic thought as Ukraine is “at the edge of Russia” (“krai” means “edge”).**

Pedagogic activity is one of the most ancient forms of the public occupancy into which people had been involved long before schools and the written language appeared. The most skillful and respected representatives of the primitive society transfer their knowledge to the

coming generation. The continuous process of accumulation and transfer of the social and historical experience gained the form of national and pedagogic traditions and laid down foundations of moral, physical, intellectual and aesthetic upbringing. The national pedagogic thought and upbringing experience of many generations were concentrated in different folk arts /1/.

It is very important to define educational possibilities of ancient lullabies, fairy tales, riddles, games and rituals. The special attention is paid to pedagogic analysis of Russian proverbs, sayings and bylinas. It is a fount of wisdom and quintessence of knowledge.

The distinctive feature of the proverbs and sayings is the objective character of the information they contain. Unlike other folklore works they do not have irreality coating and reproduce real phenomena of the social life and give clear ideas of pedagogic opinions of the nation during many centuries. The history of these brief but apt aphorisms is traditionally associated with paganism. Some of them were preserved in their original forms and others were changed under new life conditions, and the others were forgotten and replaced by new ones in the course of historical and cultural process. Proverbs and sayings in their systematized form is a true people's upbringing program that involves all spheres of pedagogic activity including teaching /2/.

Like proverbs and sayings bylinas reveal actuals of particular historical processes in people's life genesis and have big artistic and epic forms and are characterized by clear hyperbolizing of the events that took place. Narrators of the early Russian bylinas of the X-XI centuries tried to comprehend eternal philosophical and pedagogic problems related to the man's life meaning, man's ideal, correspondence of the appearance to the inner world, the good and the evil, fairness and relationship among parents and their children. The images of Ilya Muromets and Dobrynya Nikitich and other epic characters are examples of unselfish service to the motherland and special educational ideals for Russian people. The glorified epical heroes were literate as the ideal character of the hero might not be completed without it. As to the knights of medieval Europe the ability to read and write was not included into the list of seven obligatory virtues.

The new period of the bylina flourishing was in the XII-XIV centuries and is associated with the bylinas of Novgorod such as Vasili

Buslaev and Sadko. The humanistic pedagogic idea of man's value as a person, of his right for free development and ability demonstration is clearly seen in them. Vasili Buslaev is a strong and brave leader. Sadko fights the power of money and that of the sea king by his musical talent and sharpness. Besides, the role of the Orthodox Church in the moral aiming of the heroes is vivid. Thus we can state that the pedagogic ideal of a free, strong, brave, educated and esthetically developed personality that respects the Orthodox Church and its saints is represented in Novgorod bylina epos /1/.

The spiritual poetry of cripples the passersby added religious aspect to the pedagogic thought and was the result of creative interpretation of the main ideas of Christianity in the souls of Russian people. The educational ideas that spiritual verses have are close to instructions issued by theologians. The plot covers the creation of the world and the universe end and states the superiority of the man's spirituality over his bodily essence. It offers Christ and other saint martyrs as a pattern and demands observing all divine commandments and keeping to ascetic way of life.

In the XI century the pedagogic thought is concentrated not only in the folklore but in the works of ancient Russian literature. Christianity opened the way to the richest cultural, scientific and pedagogic heritage of Byzantium and it assisted greatly in raising interest in books in Rus. The original works of fathers of church and their translation as well as separate works and aphorisms of ancient Roman and Greek writers and philosophers appeared /2/.

However the strong influence of the culture of Byzantium on development of pedagogic thought and education in the ancient Russian state did not deprive them of their own identity. National and pedagogic views originated from paganism interweaved with the ideas of Christian pedagogic being either in contradiction with them or mutually complimentary. They made the joint way to understanding of the meaning and accumulation of practice of bringing the growing man up.

The native scribes corrected the style and the language of translated works in the first collections and introduced new words and expressions that characterized the Russian way of life, national and pedagogic traditions and thus brought the foreign sources closer to the ways of the world-view and life actuals of Russian people. Such translated collections as

“Zlatostrui”, “Bee”, “Gold Chain”, “Izmagrad”, “Prolog”, “Physiologist”, “Shestodnevi” and others were very popular. These were not only specific tutorials but also original reading books on the history of foreign pedagogic /2/.

All ancient works of local thinkers had didactic origin. Despite different styles and manners (“Sermon”, “Lives”, “Messages”, and “Questioning” etc.) and authors’ subjective position they had the single central pedagogic idea of moral perfection of the personality and patriotic feeling to the Motherland, concern for intellectual, physical and esthetic development of the growing person, his correct labour and family upbringing.

The “Sermon” of the Kiev Duke Vladimir Monomakh, the “Sermon” of the bishop Kirill Turovski, the “Word” and “Praying” of Daniil Zatochnik and the “Message” of the Kiev metropolitan Kliment Smolyatich were the best achievements of the pedagogic thought in Rus in the XI-XIII centuries. The humanistic orientation on the Christian ethic and integration of the authors’ life experience with that of ancestors and Byzantium theologian views is to be emphasized when the works are studied /1/.

The humanistic pedagogic ideas were developed in Rus in the XIV-XV centuries. Very important cultural changes took place on the territories that did not suffer much from the Tartars or did not meet them altogether. It was Novgorod, Tver, Vladimir and Moscow principalities. They were involved into the pan-European process of pre-Renaissance in the XIV century when Ancient Rus strengthened its cultural links with Byzantium and other European countries. These active relationships added recovered antique humanistic ideas to Russian culture and got accustomed in the territory of Novgorod that had established democratic traditions.

The Grand Novgorod was the centre of heretical movements that demonstrated humanistic pedagogic ideas in radical ways. The heretics supported secular education and mundane teachers and like humanists and Reformation figures fought for education affordable to people despite their gender, social status and income. Most of works of the heretics were destroyed. “Writing about Literacy” is one of the few that were preserved. It was written by the head of the heretic group, the embassy scribe of Ivan III, the writer Fydor Kuritsin. The author disputed the scholastic knowledge that was imposed by the medieval school and stated that it led

to ignorance. According to him the true knowledge can be obtained only by free and conscious comprehension of the material. He supported the ideas of Western-European pedagogues of Renaissance and was a century ahead the official pedagogic thought and proclaimed consciousness as the main principle of learning.

The Tartar yoke collapse and integration of separate Russian principalities around Moscow activated establishment of the single cultural and educational space on the territory of the newly formed state. Such ancient literature monuments as the “Message” of the bishop Gennadi, the Great Menology, the Code of Law of 1550, the The Stoglav, The Book of Degrees, the Annalistic Illuminated Code of Law and The "Household Book" edited by Silvestre made their contribution to it /2/.

The "Household Book" played a special role in the history of development of native pedagogic theory and practice. We would like to analyze its 1, 6, 17-20 chapters.

The "Household Book" is traditionally associated with authoritarian and anti-humanistic upbringing. But it's not quite so. It has elements of humanism peculiar for the early works of native thinkers and popular narrators. The chapter called “The Message and Punishment from Father to a Son” edited by Silvestre is a bright example of it. It is associated with pedagogic ideas peculiar for the humanists of the Western Europe. The word “punishment” used in different word combinations in the text of the “Household Book” had somewhat different more human meaning of “teaching” and “instructing”.

The pedagogic thought concentrated in the “Household Book” contained the ideas of both Christian and public upbringing. It remained a specific manual in family and social upbringing for the next three centuries /1/.

When discussing the issue of development of school education in Rus we should pay attention to the role of state and religious figures in the process, the application of foreign practice and local traditions of intellectual upbringing and organizational and methodological features of teaching.

Close contacts with Byzantium in X-XI centuries stimulated development of school education in the Ancient Rus state. The first Russian schools were controlled by the secular authorities. In the year of

Epiphany (988) the duke Vladimir opened a school of “book teaching” in Kiev. Later on the similar schools appeared in Grand Novgorod and other Russian cities. The main feature of them was that the Slavic language, not Greek as it was in Byzantium, was the language of teaching. It was associated with the established public and pedagogic traditions of intellectual upbringing and the Slavic written language created by the Byzantium missionaries Kirill and Mefodi in the IX century. The Slavic written language was based on the Greek alphabet with taking into account the specific character of Slavic dialects.

Numerous writings on birch bark and graffiti found by archeologists show that there were literate people in all sections of the population in Rus in the XI-XII centuries. It proves that the level of scholarship in the ancient Russian state was close to that of Byzantium and ahead of Western Europe. Teaching of reading and writing was done by alphabetic method modified by Kirill and Mefodi and widely used in Byzantium schools. The Psalter has been the universal tutorial for a long time. It was a fundamental one for interpreting the Bible texts. Besides, it was used to study grammar, rhetoric and philosophy. The collection of translated books that contained information on history, geography, astronomy, mineralogy was also used.

Mathematics was studied with the help of the book written by Kirik Novgorodets in 1136. Because of the scientific and methodological treatise Russian and foreign scientists call Kirik the first Russian mathematician and the founder of the Russian theory of the calendar and chronology, an ancient Russian astronomer and a talented literary man. He can also be called a remarkable pedagogue that forecasted the main principles of didactics (systemacy, consistency, use of visual methods and stability) long before V. Ratke and Y. Komenski did it. It is vivid in the book “Doctrines about Figures” which structure is logical and narration is oriented on practical application of the knowledge obtained in the real life.

Like in medieval Europe, church influenced development of the pedagogic theory and practice in ancient Rus. The most famous representatives of the monastery education in Rus were Sergey Radonezhski and Nil Sorski /2/.

When the Byzantium Empire collapsed Russian culture and education became more open for the dialogue with Western Europe. The works of such popular philosophers as Vesalius, Hevelius, Maier and

Mercator were translated into Russian. Theoretical knowledge was accompanied by the information of education and upbringing in Western Europe.

Latinization of Russian education and introduction of the corresponding scholastic methods started in the middle of the XVII century. Kiev-Mohyla Academy (1632) and Moscow Slavic-Greek-Latin Academy (1687) are bright examples of it.

The movement of Old Believers that supported the purity of Russian Orthodoxy opposed it. Its leader the archpriest Avvacum demanded refusal of studying of “outer” science and dead languages (Greek and Latin) and following the traditions of old “book learning”.

The followers of the so called greekophile school (E. Slavintse, K. Istomin, F. Rtishchev, and I. Likhuda) were guided by Byzantine pedagogic practice and called for the combination of the European school education and education traditions of Russia /1/.

As a result Russia became oriented on culture and education of Western Europe in the XVII-XIII centuries.

The role of Great Novgorod in the history of native education is important. Novgorod State University was named after Yaroslav the Wise who opened the first school in the ancient city in 1030.

The origin of the pedagogic thought in Novgorod was based on pagan culture of the eastern Slavs and some Baltic and Finnish nations and was closely interwoven with the Christian culture originated in Byzantium. It reflected historical actuals of a public, political, religious and economic life of Novgorod.

In general the culture of ancient Novgorod was democratic. Pedagogic ideas and upbringing experience of many generations could be found in Novgorod folklore, sermons, messages and treatises written by famous religious figures ( Luka Zhidiata, John, Kirik Novgorodets, Gennadi, Makari) as well as in biographies and other literature monuments (the Great Menaion Reader, and the Household Book). They had general pedagogic principles and defined a new structure of didactic ones that are still topical nowadays /2/.

Great Novgorod has always been open to the world and supported a cultural dialogue with other ancient Russian territories and people from

abroad. It was very active in adapting the best examples of their pedagogic heritage and sharing its achievements with them.

The epoch of the flowering of art of Novgorod stimulated attention paid to people's individuality, their feelings and psychological worries and filled religious plots with the elements of a real life causing the appearance of freethinking. The latter caused the movement of Novgorod heretics who were first ever bearers of the new humanistic world outlook in Rus and forerunners of humanistic traditions in Russian education.

Being united with Moscow Great Novgorod shared its heritage with the Russian state and lost some features peculiar to it. Nevertheless it managed to preserve basic pedagogic traditions of democracy, openness and respect to a book, knowledge and educated people.

The pedagogic theory and practice was developing all over the country but the role of education and pedagogues and thinkers from Novgorod in the process was remarkable.

### **Development of education theory by foreign pedagogues in the XVII-XIX centuries; "Classical" pedagogic formation.**

Significant changes took place in all spheres of the social and cultural life on Western Europe in the XVII-XIX centuries. The intellect authority and that of rational attitude to an economic and political life grew. Religious pluralism became legal and it opened the way to freethinking, democracy, research and learning. While medieval philosophy was focused on the doctrine of being, gnosiology has moved to the foreground since the age of the Reformation /1/.

The philosophers F. Bacon (1561-1626) and R. Descartes should be spoken about in this respect as they made a great contribution into development of pedagogic and natural science.

F. Bacon and R. Descartes belonged to one epoch and their philosophical systems had much in common. They initiated the split of the reality into the object and the subject. The most important thing they had in common was development of the research methodology.

F. Bacon was a founder of English empiricism. His method was based on recognition of the leading role of experience in cognition. According to Bacon cognition is the reflection of the outside world in man's consciousness. It starts with sensory perception that needs testing.



Experiments (observation and a test) are to be carried out according to a certain method. Induction (thought movement from the particular to the general) is the method according to Bacon's philosophy /2/.

R. Descartes, as well as F. Bacon, emphasized the significance of the test in scientific cognition. Intellect is the priority in the process as it directs the tests. Descartes' methodology is oriented on man's intellect that makes it rationalistic. There are two main moments in his rationalistic method. Firstly, intellectual intuition is the basis of the cognition. Secondly, the intellect is to deduce all necessary consequences out of the intuitive opinions and make conclusions based on deduction (thought movement from the general to the particular).

Descartes formulated three main rules of the deductive method:

1. Every question is to contain the unknown quantity.
2. The unknown quantity is to have some characteristics for the research to be directed at cognition of it.
3. Any question is also to contain some known quantity.

Thus, according to Descartes deduction is finding of the unknown quantity through something which is previously cognized and known /1/.

Along with the new philosophical understanding of gnosiological problems the education of the period started developing theoretical basics of teaching. W. Ratke (1571-1635) was the first scientist to make his contribution in forming of pedagogic as an independent branch of the scientific knowledge. In his works (the "Frankfurt Memorial", the "Universal Teaching Based on Raticius Method") he formed his reformatory views on school teaching with the priority of the native tongue and offered his new method of reading and writing teaching.

W. Ratke deduced 25 most important instructions in the form of the universe didactic principles that can be formulated as the following propositions:

- teaching is to go in accordance with the nature course without breaking it;
- revision is to be constantly used in teaching;
- the primary teaching is to be organized in the native tongue of students;

- teaching must not be forced;
- students are to learn by heart only the things that they understand;
- teaching is to be organized from the particular to the general and from the known to the unknown;
- teaching is to be based on induction and experience (14, p. 8).

J. Komenski (1592-1670) made the decisive contribution into forming of pedagogic as the science. He lost his parents in his early childhood, faced a lot of privations while wandering around Europe, was a member of the protestant community of the Czech Brothers, was a theologian and pedagogue by profession and was under the influence of the ideas of Aristotle, Plato, Vives, Rabelais, Bacon, Ratke and Montaigne) which he projected into education practice /2/.

J. Komenski critically interpreted and systematized the pedagogic heritage of the past and added his own ideas to them. He was the follower of the idea of teaching everything to everybody and gave the ground to the principles and methods of teaching in his main work “The Great Didactics.”

The word “didactics” originated from ancient Greece (didaktikos – relevant to teaching). Ratke called his lecture course the “didactics” or “teaching art”. The term was put into scientific operation and due to Komenski was used as the concept meaning the teaching theory.

J. Komenski considered the didactics the heart and the soul of pedagogic and paid much attention to the pedagogic basics in teaching. The can be combined into three basic principles /1/:

1. Nature conformity of teaching character and organization (“the accurate school order is to be copied from the nature”).

2. Teaching should also bring up (“nobody can be educated without the proper upbringing”).

3. Teaching is to have close links with the real life (“everything which is done is to be reasonable and prepare the way to the further serious work”).

J. Komenski developed didactic principles (consciousness, use of visual methods, consistency, systematicness and knowledge soundness) and created his class-lesson teaching system.

J. Herbart (1776-1841) whose doctrine and experience influenced the education practice in the XIX-XX centuries, made his great contribution into the development of the class-lesson teaching system. His views were formed by the influence of the antique philosophy (Plato, Parmenides), German classical philosophy (Kant, Fichte and Shelling) and some of pedagogic ideas of J. Pestalozzi.

Being both a philosopher and a psychologist he tried to base pedagogic with the help of the two sciences: he deduced aims of upbringing from philosophy and ways of the aim achievement from psychology.

According to him the main goal of upbringing was forming of a moral person and the main way to achieve it was teaching, moral upbringing and children “control”. Upbringing teaching was very important as it developed empiric, speculative, esthetic, social, religious and sympathetic interest based on stimulating and keeping of apperceptive attention and developing of volitional one.

The teaching level theory developed by J. Herbart is well-known. The first level is called “clarity” and the initial acquaintance with the material with the usage of visual aids takes place on it. The second level is called an “association” and the links between images students had and the new ones are fixed in the form of a talk. The third level is called a “system” on which the students and the teacher formulate conclusions, rights and laws, and definitions based on the new material and previously obtained knowledge. The fourth level is called a “method” and the students apply the new knowledge into practice by doing some exercises requiring logics and helping get new academic skills /2/.

J. Herbart’s teaching level theory covers all aspects of teaching. It made a remarkable contribution into the development of the class-level system. Unfortunately, many followers of J. Herbart were too formal as to the heritage and used the scheme he had proposed just as each lesson structure, which is inadmissible.

Johann Heinrich Pestalozzi (1746-1827) and Friedrich Adolph Wilhelm Diesterweg (1790-1866) made great contribution into the development of the pedagogic theory and practice. They paid special attention to developmental teaching.

Pestalozzi filled the concept of humanistic pedagogic by the idea of man's harmonic development. He thought that a child had power and skills for development since the birth as "an eye wants to see, an ear- to hear, a foot -to walk and a hand -to catch. And the heart wants to believe and love". The totality of means to develop the "intellect, the heart and the hand" was presented by Pestalozzi in his theory of the "elementary education". He implied that a child's development was to start with the simplest elements and move to more complicated ones. Pestalozzi combined physical, labour, moral and intellectual upbringing in his theory and singled out the initial element in its every aspect /1/.

Diesterweg was Pestalozzi's follower especially in the aspect of the developmental teaching didactic basics. He also thought that a child had inherent skills characterized by the desire to develop. That is why he saw the highest goal of upbringing in the individual independent development.

He thought independent actions and nature conformity to be the main pedagogic principles. He formed 33 laws of the developmental teaching and called for moving from patterns to rules and phenomena to the words that define them. He paid special attention to visual aids and advised to move from the "close to the far" and from the "simple to the difficult", from the "known to the unknown".

J. Locke (1632-1704) and J. Rousseau (1712-1778) influenced the appearance of new trends in the education history.

J. Locke declared a newly born child the "tabula rasa" and refused the traditional point of view on the man's inherent ideas, and gave the ground to the knowledge experiment origin and developed the cognition empirical theory. He understood the decisive role of upbringing and the surrounding in the forming of the growing personality and created the theory of a gentleman (a business man) upbringing.

According to J. Locke the goal of upbringing is to provide individual's happiness, the main principle of it is that of utilitarianism, the main aspects are physical, moral and intellectual and the way of getting it is home upbringing organized by highly qualified and virtuous teachers.

J. Rousseau supported the slogan of the French Revolution "Freedom, equality and brotherhood!" and had the dualistic and sensualistic world outlook /2/.

He gave the ground to the idea of the natural freedom and equality of people and showed the ways to achieve them through the new person “natural upbringing”.

J. Rousseau thought that there were three factors that influenced forming of the personality of the ideal from its birth child: the nature, the society and the people, with the nature being the main one. That is why the natural upbringing was to take place close to the nature under the conditions that were able to develop all inner power and skills of the growing person. Freedom is the first natural state of the person and thus it is to be the main principle of the “natural upbringing” /1/. He also followed the changes in the positions of a student and a teacher under the freedom.

**K.D. Ushinski – the founder of the scientific pedagogic in Russia.**

K.D. Ushinski (1824-1870) is the most outstanding figure in the history of national pedagogic. He made the special contribution in it.

K. Ushinski is called the founder of national scientific pedagogic. It does not mean that the history of the Russian scientific and pedagogic thought starts with him. He was just the first in Russia to systematize the scientific and pedagogic knowledge and form pedagogic as the science /1/.

Any science, as any pedagogic system or doctrine, has some fundamentals. K. Ushinski understood it and emphasized that “**pedagogic was a philosophical science**” and required the idea unity. He was not a supporter of any philosophical doctrine or field (both idealistic and materialistic approaches were interwoven in his world outlook) but was able to unite his own scientific preferences and views and build an integral pedagogic doctrine.

K. Ushinski thought pedagogic to be the upbringing science and **the upbringing is a purposeful process of forming a “man in a man”**. He considered the upbringing to be the social phenomenon that had its own objective laws necessary to be known and followed in pedagogic. For this the upbringing subject, that is a growing man, is to be studied (“If pedagogic wants to bring up a man in every respect it has to know him in every respect too, first of all”). The main fundamental work of K. Ushinski is “A Man as a Subject of Upbringing. Pedagogic Anthropology Practice” ; it was devoted to the problem. Unfortunately he was able to finish only two volumes during his life time in which he discussed physiological and

psychological regularities of man's development. The third volume devoted to direct pedagogic problems was not finished /2/.

While creating his pedagogic system K. Ushinski proceeded from the idea that the upbringing and education in Russia and the pedagogic science had to be coordinated with the interests of the Russians and meet them.

The papers "About the Folk Origin in Social Upbringing", "The Native Word", "About the Necessity to Make Russian Schools Russian" in which he gave the grounds and showed the significance and possible ways of organization of the family and public (school) upbringing based on the folk origin are of great importance.

According to K. Ushinski the main aim of upbringing is man's spiritual development. That is why he pays his special attention to religion as he thinks that the best typical features of the Russian folk origin were born by the orthodoxy and therefore harmonization of the religious education and the secular one is one of the main tasks of the native school.

K. Ushinski considered the labour aspect of the upbringing to be of great importance. He examined features of physical and intellectual labour and showed the role of the labour in the social and family life and man's moral formation in his paper "Labour in its Psychic and Educational Meaning".

K. Ushinski also made his remarkable contribution into the development of didactic problems. Like many other European pedagogues he emphasized the educational nature of teaching and thought it influenced not only the intellect but also the soul and the heart if it was organized properly. He considered all disciplines to have a great educational potential and especially those related with the native nature, geography, history, language and literature.

K. Ushinski supported the class-lesson teaching system. He applied the following **didactic principles** based on his pedagogic, gnosiological and psychological sets: conscious learning, its systematicness and consistency, the knowledge and skill soundness, and use of visual methods.

According to him learning has two stages. The first consists of three levels. The students perceive the thing or the phenomenon vividly guided by their teacher on the first level. The students, who are also guided by the teacher, develop preliminary images and opinions on the previously

obtained things or phenomena by comparing them on the second level. The teacher gives additional explanation of the new material, separates the main from the secondary and combines the obtained knowledge in a system on the third level. The second stage involves joint summarizing of the studied material with the further independent work on the knowledge and skill consolidation.

To consolidate the learnt material K. Ushinski offered two types of revision: passive (the student perceives the things he has seen or heard about) and active (the student produces the things he has seen or heard about independently). He gave his preference to the latter.

K. Ushinski paid much attention to the organizational structure of the lesson and marked out its different types (mixed, oral, practical and written exercises, knowledge evaluation) with respect to the class aim. Besides, he highlighted creative character of the class.

He discussed the problem of the ratio of the artistic and scientific origin in pedagogic in his paper “About the Benefit of Pedagogic Literature” and stated his views on pedagogic as a science and art.

According to K. Ushinski a teacher **is not only to teach but also to educate, that is to be a pedagogue**. He demanded the teacher to love his profession and constantly raise his qualification. He gave a detailed scientifically based program of training a teacher in the system of scholastic seminaries and pedagogic faculties which he recommended to be established at any university.

Pedagogic heritage of K. Ushinski is very topical nowadays and it can be “reread” and its principles applied in the distant learning based on the artificial intelligence.

### **Reformatory pedagogic in Western Europe at the end of the XIX - beginning of the XX century and its influence of the modern education development.**

The modern term a “reform” (from Latin *reformo* – reformation) means radical changes in any life sphere that have progressive character. That is why the concept of “reformatory pedagogic” can be considered a historical and pedagogic phenomenon that reflects progressive pedagogic ideas, concepts and educational models typical for some level of

development of pedagogic science and practice and a social and cultural situation /1/.

It is impossible to speak on the reform as progressive transformation as it can be done only in respect with something. That is why the term “reformatory pedagogic” is combined with such terms as “official pedagogic” or “normative pedagogic”. When the official pedagogic lags behind the rates of social and cultural changes and development of science and thus does not meet the modern requirements. Therefore favourable conditions for different reformatory pedagogic ideas and teaching and education practice are formed. Everything which is new gradually becomes habitual and even out-of-date. The examples to illustrate it can be found in any life and knowledge sphere. The same can be said about reformatory pedagogic ideas, concepts and models.

Analysis of the historical and pedagogic process shows that pedagogic search and education reforms are inseparable of historical events, social and cultural changes and science progress especially in the field of human study.

When the civilization passes on from one stage to another, when there are wars, revolutions and other cataclysms that cause many troubles and miseries, the mankind always turns to education as the means of improving the situation in the society through bringing up of a new man /2/.

Pedagogic preconditions of the reformatory pedagogic have the common basis and reflect humanistic and individualistic traditions in the development of the pedagogic theory and practice that were formed in the historical plan. They see the man as the highest value; recognize the freedom of the personality, the right for comprehensive development of essential forces and meeting of needs and demands. Historical roots of the traditions are in the ancient world (Socrates, Epicurus, Cicero and Quintilianus) and Renaissance (Vives, Vergerio, More, Montaigne, Rabelais, da Feltre) and the New Time (Locke, Rousseau and the philanthropists).

The reformatory pedagogic of the XIX century was rather polyphonic and had different trends. The common historical and pedagogic sources and the ideas of freedom and pedagogic centrism were the



integrating basis for the trends within the reformatory pedagogic. They were expressed in the attitude to the child (belief in it, the good that it has, its unique character and the right for the individual development), education aim (creation of the conditions for the full-fledged development of every child in accordance with its nature), organization of an academic and educational process (according to the development of children's nature and with taking into account the individual life rhythm of every pupil), organization of the school life (the principles of the fair society involving equal participation of the children, parents and teachers in the management democratic process), the teacher's position (a friend, a senior observer, consultant and advisor), relations with the municipal and state education boards (resist state and bureaucracy regulation of their lives).

Specific nature of views and activities of different pedagogues-reformers were caused by dominating scientific and philosophical ideas that influenced their world outlook forming and reflected in their pedagogic concepts.

Such pedagogues-anarchists as P. Robin, S. Faure, D. Guillot, G. Lane, F. Rauch etc. emphasized the importance of the upbringing social and labour aspect, student's independence, complete self-government and absence of any pressure from the adults.

Such pedagogues- individualists and aesthetes as G. Gunsberg, G. Gaudig, G. Gurlitt, E. Linde, and G. Scharrelmann supported the ideas of W. Dilthey and existentialism and considered pedagogic to be an independent art and cultivated individual, genius, and unique features in every child and paid their special attention to the artistic self-development of a person.

Pedagogues – psychoanalysts (A. Neill) used the ideas of Freud and his followers as to the freedom principle implementation and provided conditions for the students to implement their psychic and somatic development and created the practice of correcting care of them protecting their inner world and making them free from fear and helping them to understand themselves.

Such pedagogues- naturalists as O. Decroly and M. Montessori used results of experimental psychology and anthropology to study the inner

world of a child and adapted methods of therapeutic pedagogic to healthy children upbringing.

Such pedagogues-pragmatists as J. Dewey and K. Kerschensteiner relied on the ideas of liberalism and pragmatism philosophy ( J. Dewey's concept is called instrumentalism) considered education to be the continuous process of reconstruction of experience through teaching by doing on the basis of the personal social experience and interest of a child.

Pedagogues-anthroposophists (R. Steiner) implemented the concept of creation of full-edged comfortable to karma preconditions for the development of man's individuality.

Thus pedagogic looks for the common laws of the man's existence and reflects them in its search. We think it is important to turn to the Space laws that are reflected in different religions, science and art of different epochs.

### **Pedagogic search in Russia in the end of the XIX-beginning of the XX century.**

The end of the XIX and the beginning of the XX century was a sign of efficient innovation search in the theory and practice of education in Russia. The ideas and experience of the great Russian humanist, writer and pedagogue L. N. Tolstoy (1828-1910) played the special role in the process. His views were evolutionary and scaled and his heritage is of great importance as to forming and development of pedagogic of free upbringing.

Tolstoy showed interest in pedagogic problems in the end of the 40s. In 1859 he opened a school for children of peasants in his estate Yasnaya Polyana (Tula province). The main ideas of the theory of the "natural upbringing" of Rousseau were developed in Tolstoy's doctrine. But unlike the French educator, he tried to turn education not to the nature but to a life in which he wanted to find the complete freedom. He based on classical philosophy and Christian religious doctrines. According to him the main goal of upbringing is inner liberation of a child, development of its spiritual and moral and natural inclinations (A.A. Shatalov). The outer freedom was not important to Tolstoy and was just a secondary means to solve strategic pedagogic tasks. He was sure school must not impose anything on a child. Its goal is to offer education forces that act in a life /1/.

Such Russian pedagogues as K. Ventsel, I. Gorbunov-Posadov, O. Kaidanova, N. Tchekhov, S. Shatski and others developed the ideas of Tolstoy. We would like to emphasize the works of the outstanding theorist K. Ventsel (1857-1947) and his principles of the “House of a Free Child” and the items of his “Declaration of Child’s Rights”.

Active development of man science, experimental pedagogic and psychology, and social research caused the appearance of a new branch of science which is paedology. Such famous western scientists as E.Meumann, E. Thorndike, and S. Hall were the founders of it. The term “paedology” was offered by an American psychologist O. Chrisman (a student of S. Hall) in 1893 and meant an integral approach to studying of a child on the basis of the full-edged research of regularities of his age development.

Russia was not away from the movement of child’s studying and forming of the upbringing system based on the knowledge in regularities of child’s development. Such scientists as I. Sikorski, P. Lesgaft, M. Bekhterev, G. Rossolimo and others were involved in the problem. In 1907 M. Bekhterev opened Paedological Institute in Petersburg and established a journal “the Bulletin of Psychology, Criminology and Paedology”. A. Nechaev, N. Rumyantsev, L. Obolenski, A. Bernstein, A. Lazurski were active supporters of child’s development research. In 1906 and 1909 there were congresses on pedagogic psychology in Russia. After 1917 paedological research gained in scope. Such scientists as E. Arkin, I. Aryamov, P. Bolonski, L. Vygotski, M. Rubinstein, N. Rybnikov, and A. Smirnov gave the characteristics of child’s development in different age periods. A number of paedological institutions were established and a lot of papers on the subject-matter were published. In 1927 the conference on paedology was held and in 1928 the congress was organized. The journal “Paedology” (1928-1932) appeared (11. p. 133-134).

The views of native bio- and- sociogeneticists were quite opposite. A famous psychologist and pedagogue P. Bolonski (1884-1941) was the most consistent follower of the biogenetic concept of child’s development in our country. According to biogeneticists a child repeats all main stages of the biological evolution and cultural and historical development of the mankind in its ontogenetical development. Babyhood and early childhood correspond to the phase of the primitive society. The harmony of physical

and psychic development of a nine-ten year-old child, its pugnacity is none other than the reproduction of the phase of the man's society development in its specific forms that resembles the life of the Greek state. Teenager's detachment and gloominess is the echo of medieval relations among people. Youthful maximalism, vitality, individualism and relaxedness are the features of the new time /2/.

Sociogeneticists (S. Molozhavi, A. Zaluzhni, and A. Zalkind) emphasized the decisive role of external factors in upbringing and personality forming. A child is 90% the product of environmental influence and only 10% of its behavior is caused by instincts. The sociogeneticists paid special attention to the development of correct behavior habits. S. Molozhavi stated that the principle of educating behavior must substitute that of teaching. A. Zaluzhni thought of a children's team as a group of people reacting on the environmental factors in total.

On July 4<sup>th</sup> 1936 The Central Committee of the Communist Party adopted the decree "On Paedological Perversions in the System of People's Education Committees" in which paedologists were blamed in their intention to do harm to the Soviet school. After it all paedological experiments were over in our country and in 1937 more than 300 of educators that supported paedological views including the people's commissioner on education A. Bubnov were arrested, sentenced and exiled to Stalin's prison camps.

The first Russian pedagogue who tried to solve the problem of interrelation between labour and upbringing was K. Ushinski. By 1884 the "Draft of the General Plan of Industrial Education in Russia" had been developed. On the initiative of one of his authors I. A. Vyshnegradski (1831-1895) manual labour was an independent discipline in people's training schools. Further on congresses in vocational education recognized achievement of real education goals with taking into account actual abilities, talents and interests of students as the main aim of school classes on labour manual. At the beginning of the XX century these ideas were developed in the free education theory and practice. The largest ever in Russia experiment on implementing the ideas of labour school was carried out after the revolution of 1917. It was based on K. Marx's doctrine in which he combined teaching with productive labour and polytechnic education. The official documents declared it as theoretical and practical

acquaintance with the main different elements of production branches. The “Statute about the Single Labour School of the Russian Federation” and the “Main Principles of the Single Labour School” in which labour was considered the basics of the entire school life were adopted in 1918. The first Soviet documents that concerned school were written in the spirit of popular western ideas of J. Dewey, Lay and Kerschensteiner and others. The works of S. Shatski, P. Blonski, M. Rubinstein, A. Kalashnikov, L. Sinitski, and A. Fortunatov influenced the development of the theory and practice of the native labour school. The labour school models proposed by S. Shatski and P. Blonski were the most famous. S. Shatski supported rural labour schools. According to him their major elements should be labour productivity, art classes, and children’s social life organization with the main principles being those of child’s personal experience and interest, self-activity and self- development. P. Blonski was sure in necessity of industrial labour school that had some development stages: a children’s community, a “factory-school”, a “youth house” and a “workshop”. The pedagogues of that period had different points of view as to principles, contents, forms and methods of the labour school. But all of them saw the main task in upbringing of competent, skilled community members – collectivists.

The native scientists and pedagogues of the XX century and especially those who worked under the Soviet government paid their special attention to the development of the theory and practice of upbringing in a team. I. Pestalozzi was the first to speak about the children’s communities. P. Kapterev, P. Kropotkin, A. Lazurski, N. Pirogov, K. Ushinski paid attention to the necessity of the atmosphere of friendship and mutual assistance among children that helped their personal development.

S. Shatski (1878-1934), V. Sorokin- Rosinski (1882-1960) and A. Makarenko (1888-1939) made the most important contribution into the development of theoretical and practical aspects of children’s upbringing in a team.

Official Soviet pedagogic was based on formal ideological interpretation of the team concept of A. Makarenko and introduced the principles and methods (perspective lines, a parallel activity, self-

government, tradition forming, a combination of trust and demands, person advancing) that he had formulated.

### **Native education at the end of the XX century.**

Multidimensional historical and cultural changes in all life spheres of the country caused the review of the attitude to man as the subject of his own development in the public consciousness. It formed a new opinion on Russia being a part of the world community that obeyed the common laws of the evolution and the universal values. It also stimulated the active search of new paradigms of development of pedagogic and its practice based on humanistic and cultural priorities /1/.

Such innovators-pedagogues as S. Amonashvili, I. Volkov, T. Goncharova, I. Ivanov, E. Ilyin, V. Karakovski, S. Lysenkova, L. and B. Nikitin, V. Shatalov, M. Shchetinin were the pioneers in the process. They developed new forms of upbringing and teaching and their humanistic ideas. Some meetings of the pedagogues-innovators were arranged on the initiative of the editor general of the “Teachers’ Newspaper” V. Matveev and a famous publicist S. Soloveichick where they formulated the main conceptual items of collaboration pedagogic and included the ideas typical for their creative professional activity in them /2/.

The collaboration pedagogic is based on the following principles and ideas:

- the idea of the personality approach to a pupil;
- the idea of creative interaction and mutual assistance of teachers and students in the education process;
- the idea of teaching without any pressure;
- the support idea that is oriented on studying progress made by even the most backward pupil;
- the idea of leading that gives the chance of the advanced development of the most gifted children that provides additional time for better understanding of the teaching material;
- the idea of large blocks that helps increase the volume of the studied material, understand the main concepts and links with the simultaneous reduction of the pupil’s loading;

- the idea of correspondence of the activity forms to the learning material;
- the idea of application of the control forms that are oriented on studying without any pressure;
- the idea of the activity individual and group analysis made by children;
- the idea of the group creative control of social safety made by children and adults;
- the idea of the close collaboration with parents.

The activity and views of the pedagogues-innovators caused the great public interest and wide discussions on the problems of education and its future. Teachers, researchers, administrators and party functionaries participated in them. All concurred that the education reform of 1984 turned out to be invalid and that the Soviet school required new reforming. However, the ways to implement the reforms seemed to be different. In August 1988 two alternative concepts of the general secondary education developed by the Academy of Pedagogic of the USSR (AP) and the Temporary Scientific and Research Group (TSRG) (“School”) were published.

The AP concept was more conservative and was based on the ideology of the traditional Russian school. The concept of the TSRG was a humanistic one and was based on the advanced ideas and innovative experience.

The TSRG “School” was established on June 1<sup>st</sup> 1988 on the initiative of the Head of the State Committee of the USSR on People’s Education G. Yagodin and his Deputy V. Shadrikov. The Head of the TSRG “School” was the Minister of Education of Russia E. Dneprov, and the main body was composed of academicians V. Davidov, A. Petrovski, S. Amonishvili, V. Zinchenko, B. Nemenski (24 people). The Concept and The Provision about School of the TSRG was supported by the majority of the participants of the All Union Congress of Educators that took place on December 20-22 and gave the start to another school reform.

The stage of pedagogic search and discussions on the native school development ways was resulted in the law of the RF “On Education” (July 1992). It confirmed the humanistic strategy, formed the main principles and

tasks, and defined the ways and mechanisms of renewal of the modern Russian school.

**Conclusions.** The synchronic and diachronic links among different pedagogic ideas were analyzed in the chapter. The majority of them are useful under the distant learning organization. But there is a problem: the computer can simulate not everything in man's behavior. The methods can be of help for programmers and those who create intellectual teaching systems. By the highest standards the true computer is only a model of the left-sided thinking which is based on binary logics. The right-sided creative thinking has not been simulated so far as it is impossible to do it on a low level of that of the processor and the computer architecture. So it can fulfill only pseudo-creative functions. Nowadays there are more and more works that study the possibility of simulation of the creative right-sided thinking with the help of the left-sided which is especially important in distant learning as the main creative function of pedagogic education is defined by the right-sided thinking in general.

#### References:

1. E.V. Ivanov. History of Education and Pedagogic Thought: Teaching and Methodological Recommendations for Seminar Classes. – Veliki Novgorod: NovSU named after Yaroslav Mudri, 2002. [http://www.pedlib.ru/Books/2/0181/2\\_0181-63.shtml](http://www.pedlib.ru/Books/2/0181/2_0181-63.shtml)
2. N.V. Bordovskaya, A.A. Rean. Pedagogic. A textbook for universities. - St.Pb: Publishing House "Piter", 2000.
3. D. I. Shapiro. The Virtual Reality and the Neurocomputing Problems. - M.: RFK- Image Lab, 2008.
4. M. Badgen. Forbidden Archeology. – M.: Exmo, 2004.
5. A.P. Kovalev, S.G. Dzhura, L.V. Chernikova. Energy Risk Control (devoted to the 150<sup>th</sup> anniversary of N. Tesla) // Proceedings of Donetsk National Technical University. Series: "Electrical Engineering and Energetic", Issue 112. – Donetsk: DonNTU, 2006. – 151-153.
6. A.V. Levshov, A.P. Kovalev, S.G. Dzhura. "On the Way to Revealing of Tesla's Phenomenon (Interdisciplinary Approach) // Proceedings of Donetsk National Technical University. Series:



- “Electrical Engineering and Energetic”, Issue 7 (128). - Donetsk: DonNTU, 2007. - p. 11-13.
7. T. Pimans. J.W. Keely- Discoverer of the Free Energy // Delphis, № 2(42), 4(44) 2005; №1-4(45-48) 2006; № 1(49), 3(51) 2007; №2-4(54-56) 2008. <http://www.roerich.com/delfis/index.html>
  8. Y.V. Linnik. Sketches about New Paradigm // Delphis, №3 (59), 2009. - p. 41-46.
  9. S.G. Dzhura. Social Aspects of the Internet-Communication / Proceedings. “Language and Culture: Problems of Social Communication and Intercultural Dialogue”. Addendum to the Interdisciplinary Newsletter “Man in the Social World”. Vol.6. Tula, 2003. - p.42-51.
  10. Awards of the Project “Oriflamma”: <http://roerich.com/award.htm/>
  11. T. Davidenko. “Let the Good in and It Will Come Back to You” // Vecherni Donetsk, №166(8798) of 11.11.08; [http://iic.dgtu.donetsk.ua/russian/ovs/don.jpg /](http://iic.dgtu.donetsk.ua/russian/ovs/don.jpg/)
  12. M.A. Basin, I.I. S hilovich. The Way to the Synergonet. – StPb.: Norma, 2004. <http://www.roerich.com/zip3/synergonet.zip>
  13. Sides of Agni Yoga. 1957. - Novosibirsk: “Algim” Company. 2008. [http://www.roerich.com/zip3/grani\\_57.zip](http://www.roerich.com/zip3/grani_57.zip)
  14. G. Tesler. New Cybernetics. - K.: Logos, 2006. – 2004. –p. 57-58.
  15. I.P. Podlasni. Energy and Information Pedagogic (Textbook). - M.: Data Square, 2010.
  16. V.D. Pekelis. Your Abilities, Man. <http://biblioteka.teatr-obraz.ru/node/7489>

### **4.3. Distance learning characteristics on the development noospheric stage**

P.V. Stephanenko, S.G. Dzhura, V.I. Chursinov

*Genesis of formation of the concept of the noosphere and science development paradigms such as fractal, polytomic, creative and the knowledge hierarchy are analyzed. The hypothesis of the new approach to distant learning based on the noospheric thinking is offered.*

**Introduction.** All religions and philosophical systems are thought to be thought schools. Man learns to think during all his life. A thought is very powerful as it contains ideas that rule the world (according to Plato) or as V. Vernadski said: “The Space Forms the Earth Image”. The thought and the dream that it contains become a reality sooner or later (the ideas of science fiction writers is an example). V. Vernadski dreamt about the noosphere. It will be the noospheric epoch of understanding of strategy tasks of man’s existence and the new thinking which will lead to absolute beauty (according to Plato) which is the truth criterion and is known to save the world (according to Dostoyevsky). Roerich said: “Understanding of beauty will save the world”. We would like to start with Plato’s words: We will pass from nice images to a nice life and from the nice life to the absolute beauty”.

**The information quality criterion.** V.V.Puck spoke on the information quality criterion. With the information runaway growth it is really a problem. We are unable to read all the books related to the subject-matter of our work. That is why it is very important to know which books we should read first and what to teach. We think it is beauty that is to be the information quality criterion. It is to be the vector of finesse and loftiness. It is to be the mankind development evolution vector. The paper is the synthesis of meta-knowledge sources. This method allows examining the problem from different points of view. Here is the first example of the meta-knowledge (the Sides of Agni Yoga will be the source as it is the most authoritative and understandable one (1): “The space evolution is taking its normal course. The dark forces are unable to stop it. Earth is a special case that means nothing in the Eternity. Every earthman that joined the evolution is included into the life world flow. The one, who is against the evolution, dooms himself to the regress and destruction in the long run. The evolution wastes are destructed during a long and painful degradation stage. You can not move against the evolution for a long time being not punished. It is better to join it. The fate of some people, nations and even races that do not correspond to the evolution is sad: they are swept away from the life arena. The degeneration and degradation can last ages. We know some nations that used to be great and now are paltry. Both the Australians and the Bushmen are the remains of the races that were great in

the past. The evolution is not limited by Earth only. The star following is endless. Those who go the way do not know their purpose. The fate of man is great but it is to be understood otherwise the most important things can be missed” /1/. The thoughts are our super task and the guiding star. We think we can speak about the noosphere will expression through the meta-knowledge.

**The noosphere concept genesis.** This moment is very important for the discussion as the development of the concept starts with its definition. According to V. I. Vernadski the noosphere is a new state of the biosphere in which the total man’s intellect (the intellect sphere) is armed with the management powerful energy and earns the scale of the factor that influences the cycles of the biosphere functioning ( geo-chemical, carbon, oxygen, oil reproduction cycles etc.). We support the definition given from the perspective of the concept of the energy and information paradigm: “ The common ideas of the noosphere as the “sphere of the intellect” and the form and the result of the interaction of the society and the nature is accompanied by the attitude to the noosphere as some energy and information shell or layer in the Earth electro-magnetosphere where all the results of the intellectual, emotional, economic and word-speech activity of man and the mankind are saved” /2/.

The concept of the “noosphere” combines two ways of understanding of you in the environment: a religious and spiritual and the scientific which appeals to the intellect. Leonardo da Vinci and P. Florenski (called the Russian Leonardo) proved it by their lives. They anticipated the main aim in cognition, the search of the integral truth made by the modern man and the mankind on the way of synthesis of science, religion and art.

**The noosphere dialectics.** A.Subetto introduced a new category of the “anti-intellect” in his book “The Intellect and the Anti-Intellect” in 2003 /3/. He wrote: “...in the XX century there is a split of the intellect represented by the mankind into the intellect and the anti-intellect. The intellect is the bearer of the split to the law of cooperation and ideal determination through the public intellect, and the bearer of the future noosphere formation.

The anti-intellect embodies the defense of the plutocracy and tries not to notice the noospheric imperative, and that of sustainability through

the controlled social and natural evolution based on the public intellect and educational society”/4/.

A. Subetto showed that the anti-intellect of the plutocracy had the fate of the social and evolution self-destruction. The sphere of the «capitalist anti-intellect looks like the colony of cancer cells that eat their body-donor”.

The anti-intellect forms the capitalistic anti-noosphere (hereinafter called the egregor) that is something contradictory to the noosphere by its nature and hostile to everything on Earth which is alive. V. P. Kaznacheev writes about the noosphere in his latest works. If to use the term and add a wider philosophical meaning to it the sphere of the capitalistic anti-intellect can be defined as the global necrosphere that is the sphere of the future ecological and capitalistic death of the mankind if the anti- intellect dominates.

“The intellect against the anti-intellect is the ontological criticism of the mistakes of the civilization that lead the mankind along the market and spontaneous logic of its development to the capitalistic death, the criticism of the delusions formed by the “System of the Capital-Fetish or Plutocracy”.

An attempt to show the followers of V.I. Vernadski’s concept of the noosphere as a religious and sectarian movement is the form of the fighting of the anti-intellect with the intellect that uses unworthy methods of “consciousness manipulation” and “social virology”.

The way to the noosphere of the future is the way to the triumph of the human or humanistic intellect which transfers from the state of the self-intellect giving birth to the anti-intellect to the state of the intellect for the biosphere, Earth, the space that is to the state of the noospheric intellect!

According to A. Subetto /3/ the main reason of this transfer is the scientific thought as the planetary phenomenon, the planetary reformatory force and process, the thought planetary power as a geological factor. According to V.Vernadski the noosphere is the biosphere assimilated with the human intellect. “The biosphere has transferred or is transferring, to be exact, to the new evolution state, which is the noosphere, and is processed by the scientific thought of the social mankind” /5/. This idea is developed in the Sides /1/: “The matter (physical, astral, and mental) is spiritualized by the spirit fire. The aim of the evolution is to spiritualize, rarefy and

refine Earth and its earthly and physical spheres and transfer the brute into the spiritual and fiery. Like the essence of a huge tree is crystallized in its seed in the form invisible to an eye even through the microscope, the spirit collects the seed of the past to give the sprouts in new lives after the change of the old coatings". The noosphere is the kingdom of the intellect that influences the biosphere and changes its state which involves that of the biosphere.

N.N. Moiseev introduced one more concept of the noosphere which is the co-evolution.

The next evolution meaning is the model of the future co-natural harmony that requires the social harmony inside the social mankind, the society and is based on the being socialist origin.

The noosphere sixth meaning is in its understanding as the process of planetization of the mankind and the human thought/3/.

The noosphere seventh meaning is cooperation of the entire mankind and preserving of the existing variety /3/.

**The revolution of Vernadski.** According to scientists the scientific knowledge system evolution is regularly accompanied by revolutions that mean the change of the world scientific pictures and science paradigms: the revolution of Newton-Kopernik, the revolution of Einstein (it is sometimes called the revolution of Borowski-Einstein that denotes the appearance of the relativity theory and that of quantum). The “**revolution of Vernadski**” ranks with them.

Nikolas Polunin and J. Grünewald introduced the concept of the “revolution of Vernadski” /6/.

A. Subetto shows that noospherism as a **scientific synthesis** focused on the issues of the future noosphere and the controlled social and natural evolution formation is a part of the “revolution of Vernadski”.

If the “revolution of Vernadski” concerns the change of paradigms in the single world scientific picture through the noosphere doctrine, the “noospheric revolution” means the qualitative jump in the development of the noosphere- biosphere related to the deviation from the movement of the mankind to the trap of ecological self-destruction and the transfer to the truly noospheric and harmonic form of the man’s being which is the biosphere preserving /6/.

**The moon and sun revolutions.** The revolutions can be diametrically opposed as to their aims and results. Alexander Vladimirov offered this classification in his paper “Russia- the Way to the New World” /7/.

According to him the first type of the world revolutions and religions and spiritual doctrines that inspire them can be called the “sun revolutions”. The second type can be called the “moon revolutions” by analogy with them. For example the fascism that was spread in many countries in the XX century. Because of the world balance law the moon revolutions followed the sun ones as a response. The response is not the movement backward as there is no past any more. It is a new form of the negative confrontation of the moon to the sun. The moon confrontation, like rust, can act in the wide front and can also be consolidated towards the response sharp revolution and not obligatory in one and the same country. Many historians think of the fascism world wave to be the response conservatory reaction on the communism wave. If the reaction is the old grin, the revolution of the sun is the new enthusiasm //.

Every revolution of the sun makes its contribution into the world. According to Moses the life pivot is commonness, according to A. Makedonski it is beauty universality, according to Genghis Khan it is solidarity, according to Akbar the Great it is a religion union, according to Napoleon it is freedom, and according to Lenin it a community. Thus the revolution approved the principles of the united mankind through the nations and their leaders.

Humanism is typical for all revolutions of the sun. They were resulted in raise of human spirit and consciousness widening and enrichment.

The Russian revolution declared the idea of the Common Good. The idea was implemented in the rural community harmony in the ancient period. The community being, the so-called communism was typical for the Russian spirit long before the French city community. It was the Russian peasant community that implemented the Christian commandment of living among brothers and sisters. When the revolution in Russia won the idea of the new community that meant the unity of free labour for the common good in the interest of the Motherland and the world conquered the hearts of East and Asia /7/.

Unfortunately, there also are many examples of the revolutions of the moon in the latest history- these are the so-called “coloured revolutions”...

**The concept of the noosphere in the energy and information paradigm** is as follows /8/: “There is the energy and information sphere around Earth. V. Vernadski called it the *noosphere* (noo is intellect in Latin). V. Vernadski’s doctrine aroused interest of scientists but they did not make any practical steps in the field. Today V. Vernadski’s doctrine is being criticized because of the title and wrong interpretation. Modern psychics interpret the noosphere as the zone of negative (evil’s) energies.

Today science is sure in existence of the energy and information field around our planet. It makes the information exchange between Earth and the Universe. It contains all programmes of control of all the planetary processes taking place on Earth”.

The information fields contain all the knowledge on the Universe. The fields differ in levels that correspond to their information significance. The higher the field level (the gradient) is, the higher its information significance is. The lowest level is the information on our everyday life. The next level is the information on human communities in certain regions. It is followed by the level that informs on the life of Earth planet. Further on are the levels that characterize the state of the solar system. The highest level is the galactic one which keeps all the information on the planet and galaxy history. The higher levels are driven to absolute /8/.

**The information fields can be compared with libraries.** Every person has a small library. There are school, rural, regional, and oblast libraries. The State Library named after V. Lenin is a kind of the absolute that contains all editions ever published in our country including those of limited circulation. If we do not have the necessary information in our home library we have to turn to the higher level. There is the so-called noospheric library of the data base which is potentially accessible to any person.

The Sides tell us: “We transform the knowledge into clear and understandable formulae and pass them, laws, and principles to you. We have accumulated much. The planet **archive of the highest knowledge** collected by us is huge. We all work and accumulate and register all the findings of the mankind’s brothers. All the knowledge branches are in our

hands. People draw from them while their consciousness widens. We know much and could give much, but it is not the time yet, as the people are ready to transform everything we have, even the highest, into the destruction force. Many things are in the form of manuscripts, psychic images expressed in the layers that are not accessible to the ignoramus. The low state of the mankind only prevents it from using all the knowledge accumulated by us. Our aim is as follows: we want to arm the man by all the possibilities without any device. All the devices are imperfect attempts to implement everything which the man has and which will be available to him one day, into visual forms” /1/.

The information fields are spiritual substance. Modern physicists think that not a single material process in the Universe takes place without the information participation – the “controlling psi-function” that can be understood as the non-material (spiritual) component of all the phenomena. If the “psi-functions” control an electron movement or a proton state, there is a different non-material component, of a higher rank, at the atom micro-particle totality. Not a single creation level can do without energy support, a life-giving force and animation /8/.

The latest achievements of quantum physics prove it /9/. It concerns the solving of the paradox of Einstein Podolsky Rosen (the so-called paradox of EPR). The researchers suggested the idea of the experiment as they hoped to find the mistake of the quantum theory by its contradiction to the basic proposition of the relativity theory as to the statement that any signal is spread at a speed which is no more than that of light. Nowadays scientists are discussing “mystic” links among subsystems that can not be explained by the known physical fields and interactions. Sometimes they substitute the concept of “quantum correlation” by that of “quantum telepathy” when one object “feels” its unity with other bodies when external changes immediately influence it and when it changes something inside, it influences the environment. The well-known statement: “Change yourself and the world will be changed” is based on it, isn’t it? It is the key to self-improvement and the world perfection.

It completely corresponds to the Sides: “Man is not alone in every action of his. He is connected to the people that act and acted in the same way. Any feeling, thought or idea will link the man with the phenomenon that corresponds to his feelings through the space response”/1/. We started



our paper with the idea of a thought. Meta-knowledge pays special attention to it: “The sum of the historical reality of the mankind is made up by its thought in the combination with the evolution and its laws. It is the thought that drives the mankind”/1/.

**From the noospheric constitution to the noospheric policy.** The epoch of division, analysis and differentiation is coming to an end. The ideas of integrity, synthesis and integrated understanding of the consistent nature are back on the new spiral turn. It was illustrated by E. Illarionov in his presentation devoted to the two-volume edition “The Noosphere and Orthodoxy” which contains the proceedings of two international scientific and practical conferences in St. Petersburg in 2004 and 2005 that were blessed by Alexei II, the Patriarch of Moscow and All Russia. The representatives of some academies, institutes, research centres and organizations of information and ecological profiles supervised the conferences /2/.

Noospherism is a flow of scientific ideas aimed at forming of the noospheric model of the future mankind in the XXI century. The project “The Total Noospheric Spiritual and Ecological Constitution of the Mankind” created by L. Gordina, M. Limonad, A. Sergievski, A. Fedotov and others ranks high in the flow. The document was registered as the intellectual property of Russia and annoys such people as T. Kwitkowska, M. Kuznetsov and I. Ponkin /2/.

The main achievement of the document is the fact that the international spiritual and ecological noospheric constitution of Earth mankind was taken in consideration by the scientific, cultural and religious communities of Russia and other countries /10/.

The idea is developed on the site of the “Noospheric Spiritual and Ecological Assembly of the World” /3/. Prof. A. Subetto writes: “Noospherism is not only a new model of the being, social and natural homeostasis. It is a new philosophy, a new scientific picture of the world, new quality of man. Understanding of the self-creating nature, of the creative being in general is the most important ontological ground in the philosophy. I. Prigozhin remarked: “The Passive Universe is unable to give birth to the creating Universe” /3/.

**The Universal Noospheric Spiritual and Ecological Constitution of the Mankind** /10/ is the document that gives ground to the new form of

legal regulation in the world community in the nearest future. It gives the first ever description of spiritual and ecological aspects of man's life activity in such categories as the energy-information-matter. Researchers, lawyers, culture and international affairs experts have developed the concepts for many years. The legal document is based on the trinity of the information, the energy and the matter. The information is the structuralized energy and the matter is the compressed one. Material bodies are created out of elementary particles of the energy and the information. The Universe (the environment) is the continuous process of exchange and mutual transformations of the information, the energy and the matter.

The definition of spirituality is related with the information component (the potential energy), that of the soul – with the spirit energy coating (kinetic energy), that of the body – with the material (dense material) component. Thus the man is the combination of the spiritual and soul (energy and information) components that are closely related with the space and biological hypostasis.

The results of the modern research lead to the conclusion that further development of the civilization can take place only **in accord with the nature laws**. The moral nature of the laws of sustainability of the dynamic structure of the world is proved. **It becomes vivid that the information control culture – the spirituality- is the only progressive factor of the mankind's development.**

V.V.Putin said in his speech at the business summit “Business and Globalization”: “Our countryman V. Vernadski created the doctrine that unites the mankind in the space – the noosphere – at the beginning of the XX century. It combines the interests of countries and people, the nature and the society, scientific knowledge and state policy. It is the ground on which the sustainability concept is based today”.

The Universal Spiritual and Ecological Constitution of the Mankind is the ethic code which is in tune with the concept of the “mankind's collective conscience” that is of the life in accordance with the universe single laws. The main postulate of the Constitution is not punishment of the guilty but the justice encouragement. E. Roerich spoke on the culture dictatorship suitability: “We need to understand the main point of the world fight when psychic energy shells fly instead of gas. We need to observe unprecedented events... The concept of culture remains, and you are right

by supposing the culture world dictatorship. It is good for us to put down this year's events starting with the bank requiem" (E. Roerich, vol.1). The transfer **from the man's rights to the mankind's rights** is comparatively new. The new qualitative stage in evaluation of the right subject transforms the rights of the subject as the qualitatively new category on the traditional tested basis.

The tendency of transfer from the paradigm of competition to that of collaboration and responsibility for the entire Earth is seen in general. The mankind faces a number of problems that can not be solved by separate countries (ecological, energy, medical). In this case the collaboration is more profitable than competition. The idea is emphasized in the Constitution.

The world codes and laws that followed the Constitution are necessary to put the most general legal norms applied in different communities and states in order. The clarified concepts, the sphere of their application, the single interpretation of existing norms is one of the ways to integrate the existing forms of the society organization into the single civilization- the **mankind of the planet of Earth**.

**The main question of philosophy.** Let us recollect how many lances have been broken over the main philosophical question – what is primary – consciousness or matter. The answer is very simple and dull /8/: the matter and consciousness appeared at one and the same time as they are two sides of one and the same energy. The subtle energy can not exist without the "brute" one. Any object of our Universe emits the subtle energy in the form of consciousness or spirit. Any stone on Earth, any planet in the space and even the vacuum have energy.

The astral field (the subtle energy world) contains all energy emissions of the planet including feelings and thoughts of every person. The planet astral field is included into the general field of subtle energies of the Universe. The planet state, the way it feels sends signals to the space concerning our well-being or troubles. The similar thoughts or feelings of the people that live on Earth form thought forms or thought images. For example if many people are frightened, the thought form of the feeling appears in the space. The set of thought forms makes up the full-scale energy and information field of the Universe /8/. We think that the

noosphere can be introduced into the energy and information paradigm in such a way.

The new epoch of synthesis and integration combines the previously separated concepts into one which is the “conscious being” which is responsible for all displays in a thought, a word, a feeling and an action. All this is a form or a level of the energy and the information which has creative or destructive influence on all the components of the biosphere and noosphere organization – its internal and external environment, its being and consciousness. There is a closed cycle in new historic conditions /8/.

We can observe it on the example of DonNTU. Such specialities as mechatronics and nanotechnologies can not be studied by one faculty students. The leading professors from Germany spoke about it during the Days of German Science in Ukraine: they need not just an expert in one area. They need the one in two and even three areas. The more areas the man is an expert in, the better.

*The civilization development is accompanied by lagging behind the understanding of changes that take place in the information post-industrial society that leads to some undue risks. Those who write about it should know both engineering and philosophy for the process to be mutual. Musical drugs and traditional challenges of nowadays are among them. The modern science looks for new paradigms. Some branches of science such as astronomy, physics, and archeology underwent scientific revolutions. The papers 11-13 research formation of a new scientific paradigm. A. Einstein said: “If the idea does not seem absurd at the very first moment, it is hopeless”.*

Science is on the threshold of the synthesis of science, religion and philosophy.

The complete disclosure of the noosphere category is to crown the formation of the theoretical and the world outlook system of the noospherism which is to be **the basis for the synthesis of the single science** /3/.

The synthetic civilization revolution can be interpreted as one of the dimensions of the noospheric revolution /14/. In this case the “human revolution” is the “noospheric revolution” in the inner world of the man and in his world outlook that means the noospheric man formation /3/.

The “education revolution” being a part of the synthetic civilization revolution will gain the noospheric content. We mean the noospheric ecological education on all levels of continuous education in Russia. It is impossible to ignore the doctrine of the noosphere of V.Vernadski, the results of the research in the noosphere carried out by modern Russian scientists N. Moiseev, V. Kaznacheev, A. Ursul, A. Yanshin, B. Lichkov, K. Khailov, I. Mochalov, E. Kolchinski, V. Sagatovski, R. Balandin, F. Yanshin, A. Lapo, A. Ogurtsov and others /3/.

The noospherism is the scientific synthesis, the scientific and synthetic complex which is being formed, the new scientific world outlook system that corrects the reductive error of the closed form of humanitarian and sociological thinking that is not based on the great logic of the social and natural evolution /3/.

V. Vernadski wrote in the preface to his essay “Essays and Speeches” in 1922: “We are approaching the great revolution in the life of the mankind which is incomparable with those it underwent earlier”.

The noospherism is Vernadski’s doctrine on the noosphere which is developed into the synthesis of sciences focused on the solution of the problem of the mankind’s sustainability in the XXI century. It is to be developed in the unity with the biosphere and Gaia which are “super organisms” that support the certain system constants within the given limits with the help of homeostatic mechanisms.

The noosphere is the forming scientific and world outlook system aimed at giving synthetic knowledge to the human intellect and providing the control over the social and natural development that meets limits and requirements of the biosphere homeostatic mechanisms and those of Earth. That is why the noospherism like the doctrine on the biosphere and natural and scientific basics of interaction of the mankind (anthroposphere) and Gaia includes the entire social and humanitarian and engineering complex of sciences – human study, social science and engineering- transformed on the basis of the laws of development of the noosphere. What is at issue is the formation of /3/:

- Noospheric sociology including the theory of the public intellect;
- Noospheric human study;
- Noospheric economy;
- Noospheric engineering;

- Noospheric philosophy including the one of the noospheric intellect;
- Noospheric ecology;
- Noospheric legislation;
- The system of the noospheric morality;
- The doctrines on the developing noospheric harmony and on the total non-classical being of the mankind;
- The theory on the noospheric life standards;
- The doctrines on the noospheric socialism (communism) and other schools.

The mission of the noospherism is to provide the science block with humanitarian basis and create the proper conditions to form the universal humanitarian thinking that exceeds the limits of the tasks of the social and natural evolution harmonization.

Is the noospherism a new scientific and the world outlook system? It is according to A Subetto. The revolution of V. Vernadski is aimed at its forming /3/.

**The approaching synthesis.** According to Gödel's theorem on incompleteness of the knowledge on the fact that any complex system is contradictory and incomplete, there will be some scientific problems impossible to be solved by means of the certain science. To solve them the science will have to turn to religion and art. By applying the theorem to religion (and art) we can say that it will have the problems impossible to be solved by means of the religion and it will have to turn to the science and the art. The same can be said about the art. Penetration of one into another and usage of the ideas of each other has taken place for a long time. The religion has always used the means of the art but was in the state of war with the science. The science did the same as to the religion but supported (at least sometimes) the art. But according to the esoteric sources the synthesis is coming. Here are some typical statements of the leading representatives of the religion, science, and art.

The religion, science and art have been looking for the synthesis for a long time. Patriarch Kirill says: “Holy fathers combined secular scholarship and theology and formed a synthesis. The famous theologian archpriest Georgy Florowski called it a patristic synthesis. He wanted the modern generation of theologians to learn to combine secular culture with theological creativity for the latter to be able to enrich the culture for the

words of church to be topical. I pray and hope for the dream of father Georgy to become a reality during our life” /15/.

As far as science is concerned A. Sakharov’s idea is as follows: science is characterized by three interrelated issues: aspiration for learning and creativity; practical significance; forming of the unity that cements the mankind. The virtual reality technology provides intellectual polysensory communications with subjects (objects, phenomena) of the virtual world from different viewpoints and gives a user the possibility to form and analyze versions of distant international cultural exchange and plays an important role in the science development /16/.

Alfred Schnittke agrees with him: “The ordinary trivial intellect looks for a problem solving at its plane. It creeps on the surface bravely until it finds the way out by a trial and error method. The intellect of a genius looks for the solution by transferring into the universal level where there is the vision of everything and the right way is seen immediately. That is why the one, who saves the time for one case, has smaller results than the one, who has related cases”. /16/

The statement of Albert Einstein is also important: “The religion of the future will be a space one. It will have to overcome the conception of God as a personality and avoid dogmata and theology. It will cover both the nature and the spirit and will be based on the religious feeling that originates from the experience of the comprehended unity of all things – the natural and spiritual ones”. “Religion defines the true goal of the man. However science has to say something as to the means to achieve the goal. Those who wish to understand the truth form science, construct it, and place it into the certain frames. However, the religion is always in the science basis. I can not imagine any scientist that has no deep faith”. 2009 was the year of the 130<sup>th</sup> anniversary of Einstein and E. Roerich that had done much for the synthesis. It was she that translated the main work of E. Blavatskaya “The Secret Doctrine” which is the synthesis of science, religion, and philosophy.

It is the synthesis N. Roerich spoke about: “An ignorant person is to become civilized first, then educated and then subtle. Then he is to **understand the synthesis** that is finished by accepting of the idea of culture” /17/.

The synthesis is represented in the Peace Banner – three circles within one circle. N. Roerich interpreted it as religion, science and art encircled in culture. Madonna Oriflamma has it in her hands (the painting of N. Roerich).

D. Mendeleev said: “The time will come when the entire world is enveloped by one science, one truth, one industry, one brotherhood, one friendship with the nature” /18/. That is there is to be one proved theory accepted by the believers, the atheists, the scientists and all people.

**The educational energy and information paradigm** And what about education? The education paradigm which is the unprecedented step in the direction has been developed recently /8/. The amount of researched books and papers is impressive, the style of the book is exciting, the proposed synthesis commands respect. Many people expected such a textbook to come out. It offers the following approach /8/: “The truth, as it always is, is between the extremes. Science, if it wants to explain the matter essence correctly is to have dialectic and metaphysical approaches, which means to refuse of the extremes. It is extremely important for the human studies in which the majority of facts has not been systematized and explained yet. Pedagogic, as one of the main human studies, is to refuse of “the only one and correct” dialectic approach and apply all the best which is in the metaphysical method. It is impossible to understand the man with the help of dialectics only: there are too many areas that can not be tested or analyzed with the help of mathematics. We can move forward only by combining the dialectical and metaphysical approaches.

Metaphysical, esoteric (secret) and sacral knowledge has been thought to be a fruit of not developed consciousness for a long time. The official science refused to have anything to do with it. When there were any publications about mystic and obscure events, some official scientist gave his comments and debunked the mystic and the delusion.

Today it is impossible to ignore the alternative knowledge. It is multiplied and excludes the official one. It excites minds, is topical and in demand. It is necessary because it helps the modern man to understand our many-sided world and find his place in it” /8/.

We offer the hypothesis of a new approach to distant learning through the noospheric thinking based on the energy and information pedagogic.



**The noospheric education.** We have offered it many times. See /19-21/. What is the noosphere? According to V. Vernadski it is “the life sphere controlled by the intellect”. The energy and information pedagogic defines it as “combined rays in the form of energies made of the most subtle material particles that form the coating around Earth and are called the subtle energy world”. Astrologists call it the planet astral field. Is it one and the same thing? There also is the concept of Egregore. According to Wikipedia it is the thing soul, the “mental condensate” born by thoughts and emotions of people and having its independent being. Egregore is the information substance. From the viewpoint of bioenergyinformatics “egregor is the energy-information-time structure that appears under codirectional interaction of a group of people having common aspirations”.

There are different egregores: religious, tribal, clan, magic orders, some philosophical doctrines, creative schools, teams and social movements. That is the concept is close to that of the noosphere (only given in terms of the traditional science).

The egregor and individuals are constantly developed through information and energy exchange that helps accelerate general development of the group’s intellect.

The egregor is the group’s thoughts that act independent of each member of the group and of the group itself. That is the egregor is a part of the noosphere. There is the egregor of the Christianity, the Buddhism, the Ukrainians and the earthmen.

**The problems of the noosphere and the Internet which is the noosphere prototype.** Knowledge without moral sense is a sword in the hands of mad people. We understand it but do not do anything. The synthesis we spoke above is of great importance in this case. St.Palamas said: “Intellect which deviates from God is the beast or the evil like”. Doesn’t it concern the Internet? – Yes, and no. The oriental approach that differs from the machine binary logic should be applied in this case. The academician B.Rybakov says that any words spoken about India can be right and wrong. The same can be said about the Internet. It depends what we use it for. The Internet can work against the man ( it causes the man’s degradation) in 80-90% cases, and only a small amount of the resources does the man good, works for the evolution that is goes towards the noosphere.

The evolution in technical systems is the process of continuous optimization of biological species where the natural selection is the directing force /24/.

The evolution theory influenced people's world outlook as soon as it appeared. The theory that C. Darwin represented in his paper "The Species Origin" in 1859 was the start of the changes. But C. Darwin could not prove many of his hypothesis essential points. For example he was not convincing in showing the inheritance mechanism functioning which supported variability on the necessary level. However, the idea was rather fruitful.

It is not surprising that computer technology researchers turned to the evolution theory in order to find new solutions and inspiration. The ability of the computer system that has simple mechanisms of variability and selection to function in analogy with the evolution laws in the natural systems seemed quite attractive. It caused appearance of a number of computer algorithms and systems built on the principles of the natural selection and genetic inheritance.

The evolution computing history started with the development of a number of different independent models of the evolution process. There are three main paradigms among them /25/:

- ◆ genetic algorithms (GA);
- ◆ evolution programming;
- ◆ evolution strategies.

**Evolution algorithms as the evolution laws in esotericism (the laws of dharma, hierarchy, karma etc).** The subject matter was discussed in /26-28/. E. Roerich said: "There are many brakings but they are unable to stop the "flow of the world karma. The idea of correctness of the new construction, of the world evolution entered the new generation consciousness. There is a battle between the Light and the Dark for the common good, for the discovery of the true knowledge and beauty statement" /29/.

"The events will take eplace unexpectedly but in favour of the best country. The awful time will fly as cleaning vortex. The problem is that many of us do not understand the reason and the meaning of what is taking place on the planet. New consciousness is to love a wave of new construction. The new construction is to liberate thinking and good changes

will occur. The anger accumulated in the world will be resulted in shocks. But do not be scared! The shield of the light is over the new consciousness that refused of anger and envy and understood where the evolution flow rushed. The evil spreading will be stopped. The space justice will activate new leverage and the world new karma will be established” /30/.

People blame the teachers in injustice which occurs while the new world is being prepared. Let them achieve the space consciousness at least once and understand the space terms. The main moments of the mankind’s evolution are connected with them and the teachers’ task is to accumulate necessary for the space balance number of people with new space consciousness at a certain place on Earth.

The world politics and the world economy have never been and will never be the crucial points of the evolution. The goal of the evolution is creation of not a politically thinking man but the one who is able to think in space categories. Politics, economics and all public formations established by them teach the man to know the matter only on small and timely examples. It would be ridiculous to think the “justice” or “injustice” of these short-lived forms of the man’s public life are measures typical for the space intellect. Even some people’s karma and that of the nation are very different variables that can not be compared. Sovereigns direct people’s fates and, as an exception, observe the karma of the certain person. If Ivanov has killed Petrov, and now Petrov is trying to avenge and kill Ivanov, they will do it until one of them breaks the vicious circle and renders good for evil. The good seeds and the world evolution ideas are spread in the certain parts of the world according to the evolution space plan. Incarnation of people able to accept the ideas takes place in these very parts of the world /28/.

**From the evolution algorithms to the ethic ones.** The mankind is to discover the ethic algorithms. The ancient knowledge is coded and is difficult to read. It reveals itself to those who change themselves in the process of its studying or make those who study it with the selfish purpose mad. The modern algorithms lag it. Alfred Nobel said: “New discoveries will bring the mankind evil rather than good”. Thus the goal of studying and the application area are important. The words said by Prof. A. Minaev, Rector of DonNTU, are topical: “Many of us are virtuosos in using the computer, but not many are able to control the consciousness and sub-

consciousness which are super-powerful computers!” /31/ Each of us has the potential development possibility to be connected to the noosphere data base that makes the man stronger than any computer in the world and even all the computers connected to the Internet.

**Metaknowledge through the Internet.** To understand the problem we should back away. The more the distance is, the better we can see the matter. V.V. Puck wrote about it in his works. He stated it at the meeting with electrical engineering students of DonNTU in 1997. The administration of the Faculty has always given the chance to the students to develop new ideas. They introduced the seminar in which remarkable researchers made their presentations and thus created the environment for the ideas that was resulted in a number of projects: Moscow interdisciplinary conference and the Institute of Culture of DonNTU that renewed its work after 50 years of being neglected. The structure was presented as an additional result of activities related with the TEMPUS project (JEP-27085-2006) grant. The research showed that it was impossible to improve economics without rising of the role of culture. Thus the first postulate states that the farther we will back away the more accurate the forecast will be. G. Tesler stated the second postulate in “New Cybernetics” /32/: “There are two important results in the works of Gödel. It is the impossibility to prove consistency for any wide system that includes all arithmetic in the frameworks of the system and the existence of the principle limitation of the possibilities of the axiomatic approach. Not a single solving of the arithmetic system can make it complete. These contradictions can be solved only on the basis of meta-theories and meta-approach. The results have arithmetic proof, common methodological character, and can be applied to the systems of any nature” /16/.

**Knowledge hierarchy.** What is the knowledge? What is the knowledge? According to the definition “Knowledge is an ordered scope of new characteristics of a subject and the world and their interrelations represented in the form of a particular meta-text. The knowledge transfers separate images into the systematized meaningful form and keeps everything that can be saved, transferred and developed. **The problem of knowledge, the structure, appearance and the specific nature of its cognition and understanding is a philosophical, methodological, scientific, humanistic and applied one and can be considered one of the**

**most complicated problems” /16/. We would like to propose the knowledge hierarchy hypothesis: information-knowledge- meta-knowledge.** The ordinary non-structuralized information is the fundamental principle out of which the knowledge is formed (let us call it the applied one that is necessary for the everyday life and earnings for the daily bread). The knowledge from the capital P is the one that gives us the chance to find the way to the Eternity. It is getting of the meta-knowledge that is historically given to the mankind through prophets and Teachers. The knowledge was obtained through insights that are being studied thoroughly. Jakob Böhme, a shoemaker, William Blake, a semiliterate engraver, uneducated prophets Ezekiel and John the Apostle (with his terrible the Apocalypse), K. Tsiolkowski that had no education at all, Edgar Cayce and John Keely had such insights /4/. It is the way of cognition all great people went through including the famous power-engineering specialist Nikola Tesla. V.I. Vernadski said: “The space forms the Earth image...”

**Metaenergetics** We wrote about N. Tesla’s phenomenon in the previous proceedings of the Electrical Engineering Faculty /5, 6/. We also wrote about John Keely /7/ that was a mathematical genius and had the unique principle that made it possible to control the energy of the spatial ether. He succeeded in bringing it down to the Earth being not initiated to the final Mysteries. Although Keely’s devices operated due to the ether power, his own psychic energy was the trigger that activated it. **The result might be considered the prototype of the remote ability of the mankind to get the energy not from the Earth interior but from the Space depth.** N. Tesla and J. Keely can be called the Future Messengers. An ordinary person might want to know why it is impossible to be repeated nowadays. The answer is the following: “The representatives of the modern fifth race deepened themselves to the substance very much and were not allowed using the spiritual spatial energy (with a commercial purpose!) as it might threaten their lives and the life of the planet as its power had no boundaries both in creating and destroying” /8/. N. Tesla drove the ether by another method, and got the energy for his engines from it. The issue is very complicated and whether the mankind will transfer from ordinary exegetics to metaenergetics depends on its solving. When we say metaenergetics we mean non-fuel ecologically friendly energetics of the future. Its existence is

possible as technology ideas had been taken from science fiction and many of them were implemented (flight to the Moon, robots, submarines, the Internet etc.).

**The role of the EEF and DonNTU in metaknowledge getting.** We spoke about it at the beginning of the paper; however it was especially evident in 2008 when one of the representatives of the EEF was working at creation of the Internet resource devoted to understanding of the metaknowledge. First the material was accumulated, and then it was discussed at forums and more than 20 related projects. The history and explanation of it is given in the paper /9/. In 1991 the project Oriflamma <http://roerich.com/> on creation of the e-library on the synthesis of science, religion and philosophy appeared. In 1997 it was recognized in the I-net and got Ukrainian and international (2008) rewards /10/ that proves the recognition of understanding of the metaknowledge concept. In 2008 international experts called the project the best in the world as to the synthesis of science, religion and philosophy. The project got the diploma in the nomination of “Roerich’s Heritage Preserving”. The Director of the Hermitage Mr. Piotrovski /11/ who is the chairperson of the club of St. Petersburg’s residents handed in the diploma to the representative of the EEF at the State Hermitage. All the staff of DonNTU deserved the reward which is the motivation for continuation of the work. The paper is the contribution into understanding of the e-library ideas.

**The mankind’s knowledge.** The Oriflamma project is implementation of the idea of St. Petersburg researchers. /12/: “Knowledge, from the point of view of a separate person, is the information on possible results of the future processes in which the person is going to take part, on possible implementation of favourable or unfavourable results, on the methods and ways of influence on the possibility... Thus there are a great number of elements of knowledge of separate people that can be of help for all the people or many of them. The knowledge can be called the mankind’s one. As all the people are interested in it they have to be organized in order to solve three tasks.

1. To provide maximal (free) access to the knowledge for all the people. Such means as books (libraries), newspapers, the radio, TV, leaflets, the Internet, the Synergonet increase the survival of some people and all the mankind as it is a complicated self-organizing system.

Any structure formed by people and making financial, and information obstacles for spreading the knowledge worsens the future of the mankind and a separate quantum and is criminal. The statement can be the criterion of the criminality and the totalitarian nature of regimes irrespective of their opinion on their own democratic character. One of the main or even the main criteria of the power criminality is not only the number of people killed by the power but the amount of the mankind's knowledge that was not brought to all the society members' notice free.

2. To provide decent living to the people who participate in getting and spreading of the knowledge necessary to all the mankind. It concerns the material and information living of researchers, pedagogues, journalists, culture representatives and religious figures". We think that the matter is in the metaknowledge. It was implemented in the project Oriflamma fulfilled and supported by the EEF of DonNTU.

**The metaknowledge examples.** We would like to cite the statements on the future of the energetic and the society implemented in other being spaces "...We do not have plants, machines and factories. The spirit device has substituted them. We have all our people need. The Earth gives birth to everything that can please our bodies. We have to work much and hard. It is the physical labour to support our physical health. But the main labour area is the thought field and fine energy application. Man controls the nature forces and the elements. The forces are powerful and inexhaustible. The space gives all the mankind needs in the sense of **energy**. How hard do you work to get any type of the working energy? Fiery energy is at the man's service and we apply and use it with the help of man's microspace device. **We are close to fulfillment of the great task – to arm the man with the help of no device.** The Life Fiery Doctrine is single for all the populated worlds and the Highest Knowledge fruits are widely used here. I inform you, the earthlings, about it for you to know the main field of the evolution and life forms implemented here and to make them achieved at your Earth..." /43/. As far as science is concerned "ours differs greatly from yours as it is based on the secret knowledge of space laws which is common for all the worlds. Your official science is very young and is just approaching the understanding of the hidden forces of the nature and mysteries of the man's microspace. It denies much because of its ignorance and self-importance. That is why it is one-sided. We have the real and

practical knowledge, which is combined with the life secret doctrine as a whole; and the space mysteries and those of fine energies serve us in the current life” /13/. The conclusion is as follows: “It is the indisputable knowledge of spirit but not dreams, fantasies and groundless imagination that will lead us to the depths of the space to distant stars. You should think over the man’s space way. You will not be able to understand it if you do not learn the life in the distant worlds that are given to you as the prototype of your future achievements as the leading force and the goal ...”/43/.

**Interim conclusions.** The fragments of the metaknowledge we mentioned are to be decoded for us to understand how J. Keely’s engines worked and how N. Tesla transferred energy without any losses and planned to create non-fuel and ecologically friendly energy supply for the Earth. Even if the facts seem inconceivable we should work at them. The main thing is for the mankind to deserve the knowledge. Ethics is the main criterion or safety engineering in case of communicating with the knowledge. Therefore the task is as follows: **to develop and understand the universe ethic algorithms as “the knowledge is both obligation and responsibility”**. The responsibility for getting the knowledge is huge. It is given not in vain and not for the personal pleasure, but for its severe **application** in life” /42/. Landau meant it when he spoke about “natural science, uncommon science and supernatural science”. We think that ethic algorithms belong to the supernatural science.

Here is the viewpoint of energy and information pedagogic on the subject-matter /8/: The energy and information human being is included into the energy and information field of Earth and the Universe. The energy which is inside us is the done which is outside. Let us think about the conclusion. The result is as follows: all the information that is in the Universe is inside us. We live with it. It is ours and at one and the same time we are its particle. Man might have been called the “micro space” because of it. Not because he is a very complex and well-organized organism, but because he is connected to the huge stock of the space energy and information and keeps it inside him physically. “Omne mia mecum porte” is an ancient aphorism indicating man’s self-sufficiency. To be impartial we should mention that it lost its original meaning in ancient Rome and according to thesauri it means that a man has anything on



himself that belongs to him. It has the spiritual meaning first of all. The man has anything that belongs to him in himself. It is the information and the Universe wealth. He can take and perceive as much as he is given according to his thoughts and actions.

The process of thinking is the result of the interaction of the information field of the man with the information fields of the Universe and the environment where he lives. The environment in this case is Earth as the society where he lives. Some research aimed at finding the independence of scientific discoveries on the places they were done, were carried out in the year before last. The number of the discoveries and the probability of new ones turned out to be much higher in powerful information environments – large scientific centers and laboratories where a lot of people work. People become “cleverer”, talents are revealed and great researchers grow sooner here. The effect of “feeding” of every scientist with the energy of the general information field is obvious /8/.

Today the thinking process is the interaction of the brain with the “database” which is in the information fields of Earth and the Universe.

The Noble Prize was awarded to the English researcher Ackles for the discovery in 1994. He had studied the mechanism of interaction of the man with the information fields. It appeared that there was no consciousness in our brain. The brains had a function of the acceptor (the thought invader) but not of his producer. It can not think independently, but accepts and processes the thoughts of other people claiming them as his own.

The man’s brain is only a receiver. It resembles the telephone station with the relay system that connects him to the energy and information field of the Universe.

The brain can generate simple thoughts independently: there is no need to turn to the space bank to solve the problem whether to eat an apple now or in the evening. But when the matter is in really great products of the thought- hypotheses, theories, and concepts – he can not do without the participation of the Universe information bank. An example is the “illumination” that appears when the man works hard at a problem and sends continuous and more and more powerful requests to the Universe information bank /8/.

Researchers are not always willing to reveal “know-how” of their work. But when they exchange confidences the explanations are one and the same: the illumination comes after long period of thinking all of a sudden, and the necessary conclusions appear by themselves. Someone, like D. Mendeleev, had a dream; someone saw an image of a hanging bridge, but many suddenly discovered that they knew how to do it. It’s the “know-how”, in short.

But apples fall down not on all people’s heads. When A. Einstein was asked how he had discovered the relativity theory, he answered he had been thinking at it for a long time. Indeed, to understand something in the world one should think hard and constantly and for a long time. One is to be ready for the search. The Bible says: “Knock and the door will be opened. Look for and you will find”. Ackles says that the genius is just a constant and organized link with the information field.

The discoveries of Ackles prove that the consciousness is not in the brain. It is just the “telephone station” that connects us with the energy and information field of the Universe.

The brain accepts the vital energy from the outside and generates its psychic energy on its basis. The brain is nothing without the exchange. The psychic energy is the general and final result of the brain work /8/.

The results of the research carried out by P. Fenwick from the Institute of Psychiatry (London) and S. Parina from the Central Clinic of Southampton was published in 2001. They got the proof of the fact that the consciousness does not depend on the work of the brain and goes on living even when the processes in the brain are over. According to the researchers the man’s consciousness is not the brain function. If it is really so “the consciousness can go on living after the body’s physical death”.

“When we research the brain we see that the cells of the grey substance differ from other cells of the body as to the construction. They generate protein and other chemical substances too, but they are unable to create subjective thoughts and images which we define as the human consciousness. We need our brain as the receiver and transformer. It works as the “natural TV”: first it gets the waves than transforms them into the image and sound which compose the integral pictures” /8/.

Numerous models of exchange of the energy between the brain and the Universe have been developed. We do not doubt the main principle

although other important ones can be guessed. For example, the body's energy centre and the "antennas" tuned in to the energy channels were not found, the mechanisms of the interaction of the energy fields were not understood. A number of fantastic projects were described in the special literature. It is inadmissible that so many clever people might be mistaken at one and the same time /8/. The consciousness is not the product of the brain activity. The brain is not the stock of our knowledge. All the knowledge is in the energy and information sphere of the Universe. The man can request it from there and use it /8/.

Studying is necessary. It requires much time and power. But it must be different. It must develop the brain functions, its power and ability to generate the request and understand the information obtained from the Universe information bank. Studying carried out with the help of an experienced teacher forms the abilities to be connected to the energy and information field of the Universe and get the knowledge out. The pupil's task is to develop the main organ of the studying which is the brain. "The things" are not adapted to it.

Studying is necessary to develop the man's brain power which in its turn increases its ability to penetrate into the higher levels of the knowledge. The trained brain differs from the untrained one by the power of the energy and information field /8/.

**Egregors of the thought.** V.Puck spoke about God or the space data base. There is the metaphor in the energy and information paradigm /8/: "If vibrations are preserved, they are concentrated into the common universe information bank, the common universe intellect into which all energy flows of the alive and dead people are included. The common universe intellect knows everything about everybody. There is no doubt that the same thing occurs in other inhabited worlds. That is why the energy and information field of the Universe, the essence and the contents of which are more and more vivid, is the objective reality. The future of the human being is to find more efficient ways to be connected to it to correct the mistake the mankind has made.

We would like to be concentrated on the so-called "*forms of the thought*" which are supposed to be the units (quanta) of the human space thinking. The forms of the thought are also the way of interaction of the man with the energy and information field. They are fields generated by the

man. They are formed by the man's thoughts and his energy. They are also related to the brain activity. The more often one and the same thought is generated the more active and viable it becomes. The expressed **thought is to correspond to the vital demand of the man and to the objective reality.**

The thought generated by the man is the wave that influences both the man and the exterior. The wave is continuous by its nature and endless. If it is constantly supported by one and the same thought it can be spread throughout the Universe.

As a result the form of the thought of the man (egregor) is formed” /8/. We would like to form the hypothesis that the eregor is the concept which is the equivalent of the noosphere in the energy and information paradigm.

*We need to distinguish knowledge from awareness. The knowledge is always related to the thought and the awareness –only to emotions.* The knowledge is connected with its practical application. The awareness is rubbish that spends our psychic energy and is never applied in our everyday life. To get the knowledge we need to sift through a pile of information. The information is transformed into the knowledge when it is comprehended, checked and applied into practice /8/.

According to the research the brain can not think. The power of the general energy and information field pushes it to the thinking process. The thinking quality is defined by the system of the brain-field, and, in fact, by the system of God-man. God has given to the man all he needs in his life, but how to use the gifts is up to the man. The energy exchange quality depends on him. If the man can not arrange it, he is deep in his subjective world. He builds up his closed inner system-the consciousness- instead of the system of God-man. In the course of time this brain function dies out and the man turns into the subordinate creature.

The situation is different when the man builds his own system of God-man. The brain is connected to its natural source – the energy and information field in this case. The thinking process is fed by the God's vital energy and the highest part of the brain (neocortex) becomes active. The man's thinking becomes objective, systematic and universal. His consciousness is clear and he knows about events before they take place. His intuition helps choose correct actions in any situation /8/.

If the man wants to live a happy and long life his cognition process is to be long and continuous. We mean his ability to get the answer for any question from the information field and to analyze and generalize it, and apply to the certain situation. The continuous thinking depends on the choice. Which system to choose is up to the man /8/.

**Ethic algorithms.** Algorithm development genesis takes place while the space laws are understood. The laws are expressed in genetic algorithms, neuro-algorithms and the computer as the understandable algorithm of the man's left-sided thinking. But this hasn't given a good result so far as the amount of the knowledge that is learnt badly is growing. What shall we do for the knowledge to work for the evolution only? How to protect the knowledge from being used for the evil? The answer is as follows: we should learn from the nature. There is a famous saying that everything which is new is the well-forgotten old. We do not discover anything new in the issue. We only open the old slightly. We think the algorithms exist. They were used in ancient books and esoteric texts. Let us speak about the Bible (or the Quran or the Veda). They are coded and the reader understands as much as his inner state allows doing it. The one who knows the keys (they are thought to be 7 – mathematical, astrological etc.) understands them. According to the nature laws if the reader improves himself he understands more and more even if he reads one and the same thing. The one who does not change himself makes no headway until he finds the solution. Of course, there are some exceptions, black magicians, for example. The nature allows them lawlessness for some time but sooner or later it puts everything into place. Thus, we open the ethic algorithms (the nature cryptography) slightly. While reading cryptography books we come to the conclusion that the universe controls the man without breaking his will and teaches him to move towards the evolution. Here is an example taken from the Sides of Agni Yoga/13/: “The Light coming is preceded by the intense darkness. When the darkness comes to its zenith the forecast will become a reality. Thus you have the sign to judge upon. Everybody will bring something personal that depends upon the consciousness size to the construction of the Future Temple. For the new to be created the old is to leave. The old should make a sacrifice to the new. Many are suffering and will do it. But the evolution does not take into account either victims or sufferings. The entire species of plants and animals are destroyed in the

name of the final goal. Races and civilizations die to give the place to new ones. Luxury of Babylon, knowledge of Egypt, power of Rome, culture of Greece was replaced by new forms of the state life and buried the past under their debris. The nature is generous-destroying some forms it immediately creates new ones to replace them. The life of a person and his personal interests mean nothing in the flow. According to the life law everything which is alive clutches at the life but dies in the endless form change but preserves the essence that finds a new more perfect form under the changes. The form is nothing but the essence can not be destroyed. The experience that the form gains enriches the endless seed of the energy grain, and improves, and transforms the essence that does not die. The life essence potential in its physical form, which is nothing, is also inexhaustible. The eternal and immortal become apparent in the mortal to show their essence in the evolution endless process”.

**Ethic algorithm essence.** According to V.V. Puck the main problem of the information (or post-industrial) society is the absence of the criterion of the information quality. But the culture knows what is useful for the evolution and what is not. How can we distinguish one form another when the evil dresses itself up as the good? We need the ethic algorithms that have existed in the nature to do it. We often think about the visible universe and forget about its invisible part which is registered by devices that widen our knowledge. We can not be objective as our knowledge is very limited. We know only about 5% of the substance the universe consists of. 95% of the universe mass is collapsars the composition of which we do not know at all. G.I. Tesler has a hypothesis that they consist of the information /14/. Here is a real synthesis. V.V Puck said: “Ancient knowledge is to be transformed into scientific formulae”.

**The noosphere epoch new researcher.** What is he like? It is not the researcher we used to think of (a skeptic that does not believe in anything and doubts everything).

He is to burn but not just to be. We can read in /44/: “Do not think that our brotherhood is hidden away from the mankind by impassable walls. The snow of Himalaya that hides us is not an obstacle for those who look for the truth but for those who are just curious. You should distinguish between the one who seeks and the skeptic. Be absorbed in our work and I

will help you on the way to that world”. “Any researcher of the doctrine can get the following advice: advance with all of your power, observe by all means, research by all methods, and dare to learn, be tireless and burn from every finding of the truth. The doctrine can not be false.” /45/ The world multidimensional nature is to be taken into account. The hadrons collider has been built but if the universe multidimensional nature is not thought of, it is a meaningless thing, from our point of view. There are a lot of examples that prove it:

-“Many theoreticians are sure that the concept of the multidimensional space has all the chances to be one of the cornerstones of the new paradigm of the universe structure. It is shown in the theory of multidimensional membranes (M-theory) which is the development of the theory of strings. According to the M-theory the space has 11 dimensions” /9/ /46/ says: “Urusvati knows that people complain of unexpectedness of Earth phenomena. They might say: “We were waiting for it with our entire wish, but nothing has shown itself. But when all our power was over, it appeared”. We should comment on this: “You wanted a subtle display of your secular wishes. Can’t you understand that the earthly and the super-earthly can not be in one dimension?” /46/

- The application of ethic algorithms is the change of yourself and understanding of the new science for the common good.

- The transfer to the new synthetic thinking. “Only ignorance can think that all can be cut according to your own measure. These people act against space laws. They can not be called scientists as every true scientist is to have wide assumption...

The most remarkable discoveries can show the transfer of the researcher’s brain into the synthetic generalization” /46/

**Distant learning at the new stage.** In the basis of the education energy-and-information paradigm /15/ we can drive to the conclusion that learning process is to be as close to a student as possible. The Skype technology when both a teacher and a student see each other on-line is the most convenient now. But the energy of one practically does not meet the energy of the other. There is only a video and sound contact which is good but not enough. In this case the auras of both do not touch each other. It is a well-known fact that the atmosphere of the laboratory a researcher works at is the catalyst of his research activity. The teacher energy field might be

added to on-line broadcast. The effort might look poor as the machine is only a prop for the man. The man is to discover its own inner reserves 95% of which have not been used so far /43/. The evolution significance of engineering is in showing the possibilities the man will face: the transfer of a thought and an image on a distance (a camera and TV). The Sides say: "Let us take TV as an example. People limit its power by the bought device and become dependent on the TV centre and its programme while they have more perfect and absolutely free device in their brains and psychic organization. The people use it constantly and do not understand it. The man thinks by images. Different pictures appear in his consciousness and change each other. The process is automatic and is not controlled by the will. The thoughts flows are weak-willed and the corresponding images are weak-willed too. If there is some work to do the conscious images contact the will and it gives them the direction but does not control their flow. The trained brain of the researcher brings an order to the process, but there is no understanding of the phenomenon and its power in it. The fiery psychic device of the man is wonderful. It can be mastered to be perfect. You can take any ancient thing, concentrate on it and see all vibrations that have ever appeared on it. Not only man has a power of seeing and keeping the visible things on him, but an animal a plant and things and the matter they consist of. The matter but not them is full of not studied power has this wonderful characteristic. But the characteristic is to have a key. The man who can see and hear everything fixed by the matter or by the nature memory has the key. Akashi's scrolls are reflected in the matter the forms of which have not been recognized by science yet.

One thing is unquestionable: the thought is often accompanied by the visual subtle impression. The man sees the image of the thought that appeared in his consciousness by this eye. If the thought is concentrated on the certain question, the image flow will happen in accordance with the question. If the thought is concentrated on the certain thing with other thoughts being excluded, and then is put aside, the vibrations coming from the subject will speak and spread their energy in front of the consciousness, and you can see fragments and then the entire pictures of what the thing saw around it once.

The walls of ancient buildings have seen much, much is seen by the walls of dwelling houses and they imprint everything that takes place inside



them. If the man's centres are subtle enough, he can also see it. The strata cause many transient and incomprehensible feelings. Unfortunately, people do not wish to realize what they see, hear and feel behind the stereotype. We can feel both man and things. Women are more sensitive in this respect. Before man is able to unlock the wonderful device which is inside him, he will need to demonstrate keen vision and power of observation as to his impressions. First he is to know about the device existence, then to understand its possibilities and value, and then to activate it carefully and step by step. The coming new fiery epoch gives the man new opportunities that require comprehension first of all. The ability of the man to see with the third eye and arouse the image of any thing is to be paid a special attention to. Too little attention is paid to the amazing creative ability to make desired images out of the subtle matter; however it is the basis of everything that has ever been made by the man. The man can not create anything without preliminary forming of images invisible for man's eye of what he wants to implement in his earthly life in their visible forms. First of all it is he who sees the images created by him. But some other person can also see them, invisible for an eye, by his third eye. When a listener hears about a new construction plan or draft he sends desired images to his consciousness with the help of words. But the perception can occur directly, without any word. The thought transfer is based on it. So many thoughts and images are transferred and received every hour without the process being understood! There are many people who deny the wonderful world around them and the possibilities they have in their hands. They should forget about their denials and just open their eyes to see. The man can see and hear beyond the usual abilities /1/.

Man's aura investigation (its symbol is shown on the example of the toy Russian dolls). We can also speak about the aura of premises and people. When we come into it everything goes by itself and understanding of the previously impossible things takes place in the team and the room. The ordinary knowledge (horizontal, for the life earning) can be broadcast on a distance. To understand something which is deeper we need to make our own way to the teacher. There is an oriental saying: "The teacher comes when the student is ready". It is great luck for both. The Sides says /42/: "The intimacy with the teacher is to be looked for in the spirit. It is accessible in the spirit. You can be elevated by the spirit with your body

being fined. If the spirit is high it elevates its coats as a balloon raises a basket with its ballast. Spiritualization of physical, astral, and mental matter made by the spirit mental fire takes place. The evolution goal is to spiritualize the Earth and its physical spheres and transform the rude into the spiritual and fiery". It is a super task, the future distant learning. The traditional approach to education is in getting a book, a leaflet, or a film. It is not a problem in the information epoch as the knowledge is accessible (open and noospheric libraries). But there is a problem in the knowledge extraction. The real (vertical) knowledge is usually coded. It helps laymen. The Bible has seven keys without which it is impossible to understand it totally. When a recipient gets the knowledge because of some reasons and uses it in super selfish ends it is called the black magic. The space laws are legal on the Earth and behind its limits and not only in this but in future lives. This means that punishment will take place anyway. The birth of monsters is explained by it. It is not only the fault of parents (sometimes the monsters are born from decent parents). The future of distant learning has two versions. The first is the traditional one – the inner improvement (computers, communications, and software). The second one is oriental – self-improvement and the teacher will come in time to him who knocks at. /42/ illustrates the idea: "The wish to get the certain knowledge predetermines its getting. It also concerns any strong and legal wish. It becomes a reality very quickly. We help in everything that concerns the common good".

**Conclusions.** The innovative approach of the energy and information concept of education development is a decisive one /8/. Different education technologies (distant learning in particular) can be developed in the frameworks of the concept. The mankind will be faced with understanding of ethic algorithms of the universe which are paid attention to in the paper. We might take a technocratic lesson (of inner perfection) at the new stage of the mankind's development and come back to the life simplicity when there is no need in machinery. Then we will not need the distant learning as teacher's coming to a student might happen in any space of the being. "The phenomenon simplicity is not accessible for people as the life great laws are too simple for the people to accept them without wandering around. All which is great is simple. As far as the simplicity is not typical for people the great is difficult. Communication in the spirit and by a thought is easy

and accessible. But who believes in it? How many years did we need to get into contact with Guru? Thinking wheels rotate slowly as there is no simplicity...”/42/ We will learn **the “new” method of knowledge getting to which the evolution is preparing us**: “How big is the amount of interesting findings the man faces! The entire world is open for learning but not through the brain. The communication goes through the same channel through the heart. The heart grows and is deep in the subtle work. We should develop feelings. The knowledge comes to their centres and reaches the consciousness. The spirit knows much. The knowledge of the spirit and the feelings are inseparable. Both mean the direct knowledge without interference of the brain. When the consciousness is concentrated on getting the direct knowledge it gets it if the brain is not allowed to interfere into the process. The brain in this case acts as an accountant of the facts that come into the consciousness. But the knowledge getting itself takes place without it. The spirit and feeling knowledge is a new method to get the knowledge and obtain the information for the subtle consciousness.” /42/ We will not need ordinary libraries as we will use the natural ones as all the knowledge is in the noosphere and can be got from there directly. It will be a new stage of the mankind’s development. Esoteric sources which are accessible for people show how to get there.

We would like to wrap it up by citing the Sides: “My son, the feeling that you can perceive and fix the thoughts that come from the space is correct as the access to the space thought depository is open. There also is the access to the thought ocean. The learning ocean is open only to the nearest. The ability will be clearer in the course of time. It won’t be limited by the communication hours; it will always be open if the spirit wants it. The ability comprehension is to be introduced into life and be used if there is a wish. It is as if you always have the telephone set at your hand and you can be connected to the desired object or as if you have the radio set and can listen to the favourite channel any time you want. The spirit device is much better than the devices that have been invented, are being invented or will ever be invented. All of them are just a rough imitation of what is inside the man. Lenses, binoculars, colored photos, films, the telephone, the telegraph, the radio, and the TV and vibration devices are inside the man in the forms that are more perfect than the physical devices. The binocular is to be regulated according to the eye, but your eye does it automatically.

You need some time to get a photo. Your brain and your eye do it immediately. You even need some time to send the radio telegram. Your thought is as quick as lightning. You do not need to go to the cinema theatre to see the film. The person who drowns sees his life as on the film. But to see the event astral films you do not need to drown. If you have such ability, it can show itself in more appropriate conditions. It is good to fly being on board plane but it is faster, cheaper and more interesting to do it in the subtle body. Everything is inside the man. It is to be understood first and then the abilities given to you by your body are to be applied. It will be your great inheritance prepared by Father of everything to his prodigal sons. Father is waiting and so is the inheritance. Come and get it. It is yours from the time being”.

The new understanding (from the metaknowledge) of the machine essence is one more crucial conclusion: “The machine is an interim phenomenon. It is true, that some devices will remain for long even on the highest plans, but the final goal is to be free of mediating devices and operation of the spirit fiery power when the devices are concentrated in the man’s micro scheme. The planet creator acts without any device. There are no devices in the infinity. They exist on the prototype plan as models of what can be implemented on Earth at a proper time. We need to understand and use the man’s fiery devices such as the telephone, the telegraph, the radio set, the camera, the TV, the device to project space cliché of the past, present and future on the consciousness screen in the third eye. The sound and hearing set allows hearing in the distance, the visual one – seeing. The energy set allows transferring the energy both in the distance and during the direct contact. Harder energy types which the man uses when he works, moves etc. are obvious and are not to be proved. We can feel an electric impulse run on nerve wires and carry the fiery current of psychic energy. The man’s device is extremely complicated and its power is inexhaustible. Thus we need to start mastering it and apply the wonderful devices into life. The man constantly radiates different energy types. They can be directed consciously. Their power is extraordinary if they are understood and the will controls them. There is no way except for mastering all the wonders of the fiery device which is inside the man. You can not study them theoretically. You should just live and apply the learnt laws of the subtle laws in your life” /1/.

## References:

1. Sides of Agni Yoga. 1956.- Novosibirsk, Algrim Company. 2009.  
[http://www.roerich.com/zip3/grani\\_56.zip](http://www.roerich.com/zip3/grani_56.zip)
2. V.A. Frolov. Noosphere Liturgy and Russian Philosophy// Delphis, 2007, №2 (50). – p. 39-43.
3. A. I. Subetto. Noospherism: the movement, ideology or a new scientific and world outlook system?- <http://www.newhumanity.ru>
4. A. I. Subetto. Intellect and Anti-Intellect (what are we to expect from the oncoming day?)- StPb. – Kostroma: State University, 2003. -148p.
5. V.I. Vernadski. Philosophical Thoughts of Naturalist. - M.: Nauka, 1988.
6. Vernadski's Revolution in the System of epy Scientific World Outlook – Search of the Noospheric Model of the Future Mankind in the XXI Century (the collective monograph)/ edited by A. Subetto – StPb: Asterion, 2003. – 592 p.
7. A.V. Vladimirov. Russia- the Way to the New World.- [http://www.roerich.com/zip3/vlad\\_ros.zip](http://www.roerich.com/zip3/vlad_ros.zip)
8. I.P.Podlasy. Energy and Information Pedagogic (Textbook). - M.: Data Square, 2010.
9. O.O. Feigin. The Great Quantum Revolution.-M.: Exmo, 2009.
10. L.S. Gordina. The Concept of the Mankind's Constitution //Delphis, №3 (34) 2004. – p. 2-6
11. M. Badgent. Prohibited Archeology. – M.: Exmo, 2004.
12. Yu. V. Linnik. New Paradigm Etude// Delphis, №3 (59), 2009. - p. 41-46.
- 13.E. V. Zorina. The Paradigm of Scientific and Non-Scientific Knowledge (Speculations at the Front Door of Science) // Delphis, №3 (59), 2009. - p. 47-51.
- 14.A. I. Subetto. Noospherism. Introduction to Noospherism. Volume1. - StPb.: Asterion, 2001; 2003. 538p.
15. Speech of Patriarch of Moscow and All Russia Kirill in the Kiev-Pecherskaya Laura. <http://patriarh.in.ua/uk/node/421>
- 16.D. I. Shapiro. The Virtual Reality and the Problems of Neurocomputing. -M.: RFK-Image Lab, 2008.

17. A.P. Kovalev, V.V. Otkidach, S.G. Dzhura. On the Track to a New Syntagma // Wisdom of Earth Home. About the World Outlook of the XXI Century. Edited by S.G. Dzhura, V.A. Yankina, and A.B. Kazanski. - StPb. –Donetsk, 2007. - p. 160-169.
18. Yu.A. Urmantsev. Nine plus One Etude about System Philosophy (the Outlook Synthesis). – M.: 2001. [http://raen-noos.narod.ru/lib\\_urmancev1.htm](http://raen-noos.narod.ru/lib_urmancev1.htm)
19. V.S. Lysenko. Contours of Noospheric Pedagogic. <http://torrents.ru/forum/viewtopic.php?t=1574669>
20. N.V. Maslova. Noospheric Education: Methodology, Technology, Tools. <http://raen-education.webhost.ru/b-masl3.htm>
21. N.A. Bezzubtseva. Noospheric Education – from the Past to the Future. <http://elibrary.ru/item.asp?id=9925865>
22. V.A. Zubakov. Wisdom of Earth Home (about the World Outlook of the XXI Century). – StPb, 2003; <http://www.roerich.com/zip2/maneb.zip>
23. V.V. Yemelianov, V.V. Kureichick, V.M. Kureichick. Theory and Practice of the Evolution Modeling. – M.: Physmatlit, 2003. – 432 p.
24. A.V. Nazarov, A.I. Loskutov. Neural Network Algorithms. – StPb.: Nauka I Tekhnika, 2003.
25. V.N. Bondarev, F.G. Ade. Artificial Intelligence. – Sevastopol: SevNTU, 2002. – 615 p.
26. A.I. Klizovski. The Grounds for Understanding of the New Epoch. - [http://www.roerich.com/zip/os\\_mirop.zip](http://www.roerich.com/zip/os_mirop.zip)
27. A.A. Makarov. Great Laws of the Space // Delphis, №3 (43), 2005.
28. P.F. Belikov. The Family of Roerich. Spiritual Biography Practice.
29. E.I. Roerich. Letters. Volume 2. – M.: MTR, 2000. - [http://www.roerich.com/zip2/ei\\_2.zip](http://www.roerich.com/zip2/ei_2.zip)
30. E.I. Roerich. Letters. Volume 1. – M.: MTR, 1999.- [http://www.roerich.com/zip2/ei\\_1.zip](http://www.roerich.com/zip2/ei_1.zip)
31. A.A. Minaev. Speech in front of Master's Students. - Donetsk: Donetsk Polytechnic, №14-15.
32. G.S. Tesler. New Cybernetics. – K.: Logos, 2006.- 2004.- p.57-58.

- 33.L.N. Melnikov. The Virtual Reality and Space Consciousness // Delphis, №2 (46), 2006. – p.111.
- 34.A.P. Kovalev, S.G. Dzhura, L.V. Chernikova. Energy Risk Control (to the 150<sup>th</sup> anniversary of N.Tesla) // Proceedings of Donetsk National Technical University. Series: “Power Engineering and Energy”, issue 112. – Donetsk: DonNTU, 2006. - 151-153.
35. A.V. Levshov, A.P. Kovalev, S.G. Dzhura. On the Track of the Solution of the Phenomenon of N. Tesla // Proceedings of Donetsk National Technical University. Series: “Power Engineering and Energy”, issue 7 (128). – Donetsk: DonNTU, 2007.-11-13.
36. T. Pimans. J. W. Keely – the Discoverer of the Free Energy //Delphis, №2(42), 4(44) 2005; №1-4(45-48) 2006; №1(49), 3(51) 2007; №2-4(54-56) 2008.  
<http://www.roerich.com/delfis/index.html>
- 37.E.P.Blavatskaya. The Secret Doctrine (in three volumes)- Kharkov: Exmo Pholio, 2008 <http://www.roerich.com/zip/td1part1.zip>
38. S.G. Dzhura. Social Aspects of the Internet-Communication. The Proceedings “Language and Culture: Problems of Social Communication and Inter-Cultural Dialogue. Supplement to the Inter-Disciplinary Scientific and Practical Newsletter “Man in the Social World”, volume 6, Tula, 2003. - p. 42-48.
39. Awards of the Project Oriflamma : <http://roerich.com/award.htm/>
- 40.T. Davidenko. Let the good in and it Will Come Back // Vecherni Donetsk, №166(8798) of 11.11.08;  
[http://iic.dgtu.donetsk.ua/russian/ovs/don.jpg /](http://iic.dgtu.donetsk.ua/russian/ovs/don.jpg/)
- 41.M.A. Basin, I.I. Shilovich. The Way to Synergonet. – StPb.: Norma, 2004. <http://www.roerich.com/zip3/synergonet.zip>
- 42.Sides of Agni Yoga. 1957. – Novosibirsk. Algim Company. 2008.  
[http://www.roerich.com/zip3/grani\\_57.zip](http://www.roerich.com/zip3/grani_57.zip)
43. V.D. Pekelis. Your Abilities, Man. <http://biblioteka.teatr-obraz.ru/node/7489>
44. Call (Leaves of Moria’s Garden) -  
<http://www.roerich.com/zip/zov.zip>
45. The Fiery World, p.1. - <http://www.roerich.com/zip/mo-one.zip>
46. Brotherhood, parts 2-3, Overhead.  
<http://www.roerich.com/zip/brtwo.zip>

#### **4.4. The outlook of application of artificial intelligence in distance education**

A.V. Levshov, S.G. Dzhura, A.A. Chursinova

*One of the most promising systems of distance learning is analyzed in the paper. Its application in the distance learning courses for electrical engineering students is shown and the teaching method is given.*

**Introduction.** The authors of the paper have been occupied with distance learning since 2005 /1-9/. They would like to share their findings and the latest elaborations in the field. The project of distance learning courses for electrical engineering students presented in the paper is based on the knowledge obtained at a number of conferences, professional development courses organized at DonNTU by their French colleagues, analysis of different publications and contacts with the developers.

**Distance education.** Distance learning is one of the forms of learning recognized in Ukraine. Intense development of the distance learning started in Europe and America in the 70s. This form of learning was introduced in Ukraine in 2000.

The distance education in Ukraine is regulated by the Concept of Development of Distance Education in Ukraine and the Statute on Distance Learning of the Ministry of Education and Science of Ukraine. It means the complex of education services given to students that are far from the university they study at with the help of the special information and education environment based on exchange of the academic information with the help of modern telecommunication technologies.

The people having their certificates on secondary education, professional education, higher education (except for the juridical one) that are able to obtain knowledge and work in accordance with the working plan with the help of distance education technologies can get the distance education.

The process is carried out through the Internet and other communication and engineering means. Studying at the courses is organized in accordance with the academic plans. To get the certificate the students are to do some scheduled tests or projects.



The terms of studying are as follows:

- For those having the secondary education certificates – 6 years;
- For those having their secondary professional education certificates – 4.5 years;
- For those having their university degree (except for the juridical one) – 3 years.

In the majority of cases there is a tuition fee. However some companies offer free distance learning and it concerns the course demonstrations.

There are three traditional forms of academic institutions that offer distance learning:

- “Natural” distance universities;
- Providers of corporate trainings and/or professional development courses;
- Traditional universities that offer on-line education.

There are several models of the distance learning:

- Study for an external degree;
- University studying;
- Collaboration of some educational institutions;
- Independent educational institutions;
- Independent training systems;
- Non-formal integrated distance learning based on multi-media programmes.

### **Distance learning system structure.**

The concept of distance learning was known at least in 1892 when the courses were opened at one of the universities of Pennsylvania State. In the 70s of the XX century two guys from Long Island Ben Cohen and Gerry Greenfield attended 5dollar distance learning course on making ice-cream. The obtained knowledge helped them to found their own ice-cream empire.

That is, the distance learning is much older than computer technologies including the Internet. However the links between the distance learning and network computer technologies are so strong that it is impossible to imagine the existence of one without another.

The “weak” link in the computer distance learning, as in any new sphere of man’s activity, is its terminology. Different authors give different interpretation of one and the same concept, or call it by different terms. It caused the situation when the experts of one and the same sphere speak different languages! We mentioned the international standards that regulate some aspects of the structure and application of training systems in the previous parts of the book. They are in English; there are no official translations of them into Russian and it can cause alternative versions. If any of our readers has some objections as to the version offered by the author, do not hesitate to contact us.

Let us start with the concept of “distance learning”.

**Distance learning system architecture.** At present there are two terms for the technology under discussion: distance learning and e-learning. Both mean learning with the help of the Internet but with the different degree of its application.

The Internet (or other network technologies) can be used in the distance learning but it is not obligatory. The e-learning means exchange of data between a teacher and a student on-line.

Some of our readers might associate the term of e-learning with that of e-book, which is the training programme that is spread in different ways (most of all on CDs). However according to the modern classification e-books are means of CBT — Computer-Basic Training.

To dispel doubts we would like to repeat that the term of e-learning is the « direct descendant » of the terms of eCommerce and eBusiness. The corresponding activities are based on the Internet technologies, but not on the computer (information) technologies in the common meaning.

The difference between the two terms is getting less and less noticeable in the countries with the higher level of computer technology development as compared with Russia. The terms of e-learning and distance learning are used in one and the same meaning even in one Internet site (for example the site of the company IBM on the product LearningSpace fig. 1.13).

The term of e-learning is less popular in Russia and the distance learning is understood as all forms of removed learning based on the

Internet technologies only. The site of the Distance Learning Centre of the Academy of National Economy (fig. 1.14) is an example.

We are going to discuss the e-learning technology and if you come across the term of the distance learning it should be taken as the synonym to the e-learning.

Any e-learning system consists of two parts: the client (or the running medium) and the server based.

The Web-browser interface is the basis of the running medium user interface. In this case the academic course interface can differ from the browser interface. The situation is possible when special tools such as Authorware are used to develop the client part of the training programme. As a rule there are two components of the client part of the e-learning: the learning sub-system and the diagnostic sub-system (partially). We say “partially” because test result processing and test generation is made by means of the server part.

The server part of the e-learning system is also implemented on the basis of the special software such as LearningSpace which has already been mentioned and Pathware the joint product developed by the companies Macromedia and IBM Lotus. The special term of Learning Management System (LMS) or its analogue Computer Managed Instruction (CMI) is used to name the e-learning server part.

The main functions of learning control system are sometimes called 3R (Registration, Routing, and Reporting).

*The registration subsystem* provides putting down of new data on students into the data base, initializations of the current session for the students who were registered before. Besides it is able to import the registration data (a student’s name and the registration number) from other sources.

*The routing subsystem* provides processing of the current connection and controls student’s passing of the parts and modes of the training programme by giving him a corresponding menu. The more “advanced” routing subsystem can control the route choice automatically on the basis of some logic conditions (the goal, test results, the content of the previously learnt topics etc.).

*The reporting subsystem* allows getting information on the results and marks which is sent to the training programme administrator. Developed control systems allow statistic analyzing of the training process data.

A good control system is considered to be a special bridge that unites different means and e-technologies of the training material. Besides, it is to meet current standards. The requirement is caused by two modern concepts: continuous education and system implementation openness. We mean that any user is to have a chance of endless continuation of his education and to learn the principles of the next training system, and the system is to recognize the user and take the user's data accumulated by other systems.

**Modern standards for the distance learning systems.** A number of international organizations, consortia and national committees of some countries collaborate in development and standardization of the elements of system approach to the distance learning system construction and other training systems functioning on the basis of information technologies.

The accredited Institute of Electrical and Electronic Engineers (IEEE) and Learning Technology Standards Committee (LTSC P1484) play the leading role in the process. They coordinate the operation of the following organizations:

- the international project Instructional Management Systems (IMS)Global Learning Consortium that develops technological specifications of the Internet/Intranet technology based e-learning;
- the EU project ARIADNE (Alliance of Remote Instructional Authoring and Distribution Networks for Europe) which develops tools and methodologies for production, control and multiple usage of pedagogic elements based on computer technologies;
- the international committee AICC (Aviation Industry CBT (Computer-based Training) Committee) which is aimed at developing and applying of information technology based training systems;

- the USA ADL Committee (Department of Defense Advanced Distributed Learning) aimed at defining the requirements to training technologies.

There are some other organizations involved in development of standards and specifications of training systems built on the basis of information technologies.

The final documents are developed by the IMS consortium. As they are well studied, have practical orientation, are based on recommendations and practical experience of other interacting organizations the documents published by the IMS gain the standard status. Although they are of recommendation nature many companies that produce software take the standards into account. The company Macromedia is among them.

The following technology elements of development and application of the e-learning systems are standardized at present:

- Content Management Information Model — CMIM; it describes general requirements to the form of representation of training material (irrespective of the subject matter and the methodology of training); its goal is to create the single information model to provide correct interaction of the client and server parts of the training program;
- Content Package Information Model — CPIM; it defines the composition and the form of the information presentation while sending it to a user;
  - Question & Test Interoperability — QTI; it describes general requirements to the structure and presentation of the data used when the test questions and tasks are prepared and sent to a user.

The interaction between the information models of the course data is shown on the fig. 1.

The data transfer protocol is defined by the service supplier of the training system control (the organization – vendor).

**The data model to control the content.** It describes the way the DMS controls the course content which is reflected on the trainee's side.

The model main concepts are as follows:

- Visibility — accessibility of the course ( or some of its parts) for the certain trainee;

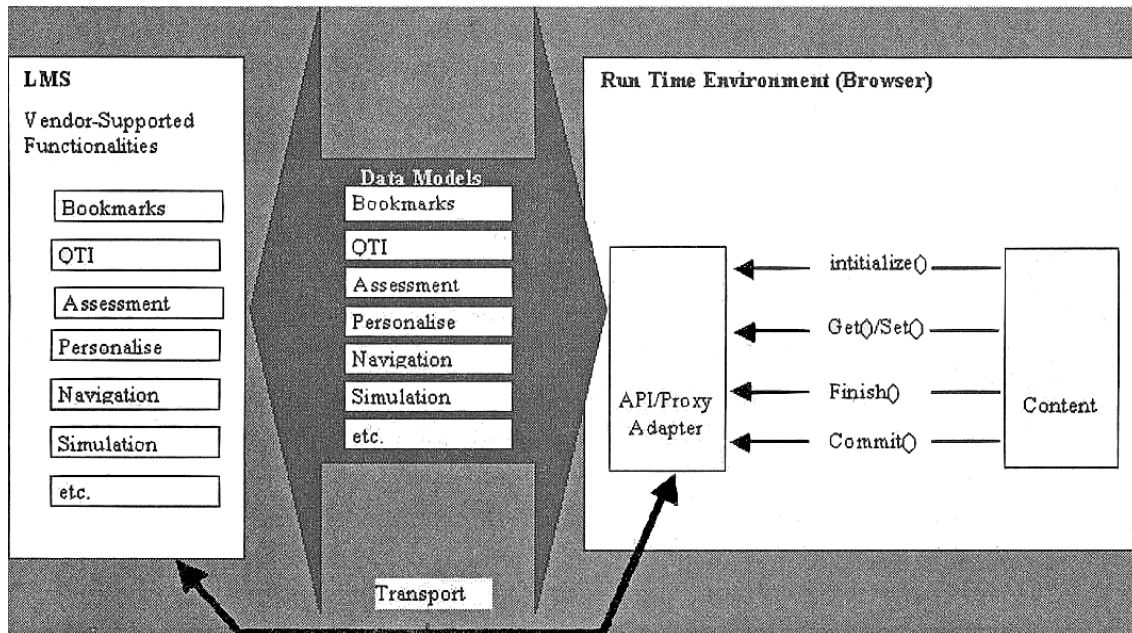

Fig. 1. The training model structure

- Navigation — the mechanism of movement of the trainee among the chapters, pages and modes of the training course;
- Presentation — the size of the visual representation of the training course elements;
- Aggregation — the rules of division of the course into fragments and control of the fragment hierarchy.

There are some certain implementations of the course content information model. The model SCORM (Shareable Content Object Reference Model) created by the ADL Committee is the most popular one.

**Conclusions:** The examined programme of the distance course implementation is prepared and applied for electrical engineering students studying the course of “Mathematical Methods and Models to Solve Tasks with the Help of the Computer”.

#### References:

1. S.G. Dzhura, V.V. Otkidach, V.I. Chursionv. On the Way of Forming of the Human Planetary Intellect // Proceedings of the IV interdisciplinary

- scientific conference “Ethics and the Future Science” – Life in the Universe. –M.: Delphis, 2005. – p. 199-205.
2. V.V. Otkidach, S.G. Dzhura, A.A. Chursinova. Information Paradigm – the Open System Theory // Proceedings of the III scientific and practical conference “Ecology Problems of Industrial Megalopolises”. M.: MGYIE, 2006. – p. 106-109.
  3. P.V. Stefanenko, S.G. Dzhura, A.A. Chursinova. Eurointegration through the Distance Learning with the Application of the Artificial Intelligence // Proceedings of the international scientific and methodological conference “Eurointegration of the University Education on the Way of Creation of the Knowledge Community”. Alchevsk: DonSTU, 2007, - p/ 236-245.
  4. P.V. Stefanenko, S.G. Dzhura, A.A. Chursinova. Opportunities of Application of the Artificial Intelligence in Distance Learning // Proceedings of the XIV international scientific and technical conference “Manufacturing Engineering and the Technosphere at the Turn of the XXI Century”. Volume 4. – Donesk: DonNTU, 2007, - p. 8-13.
  5. P.V. Stefanenko, S.G. Dzhura, A. A. Chursinova. Pedagogic Aspects of the Information Technologies on the Noospheric Stage of Development // Proceedings of the 5<sup>th</sup> international conference “Creative Heritage of V. I. Vernadski and Problems of Forming of the Modern Ecological Consciousness. – Donesk: DonNTU, 2007. – p. 315-319.
  6. P.V. Stefanenko, S.G. Dzhura, S.A. Isakov. Taking into Account of Cognitive Thinking in Distance Learning // Proceedings of the XV international scientific and technical conference “Manufacturing Engineering and the Technosphere at the Turn of the XXI Century”. Volume 3. – Donesk: DonNTU, 2008, - p.175-178.
  7. P.V. Stefanenko, A.V. Levshov, S.G. Dzhura. Distance Learning in the Light of Energy and Information Paradigm // Humanitarian Newsletter. Series: Pedagogic: Ukrainian proceedings. Issue 1. The Ministry of Education and Science of Ukraine. Cherkasi State Technological University. – Cherkasi: CSTU, 2009. – p. 114-130.
  8. P.V. Stefanenko, S.G. Dzhura, V.I. Chursinov. Peculiarities of Distance Learning at the Noospheric Stage of Development // Proceedings. Series: Pedagogic, Psychology and Sociology. Issue 7 (167) – Donetsk: DonNTU, 2010, - p. 33-47.

9. P.V. Stephanenko, S.G. Dzhura, V.I. Chursinov. Peculiarities of Application of the Artificial Intelligence in Distance Learning // Proceedings of the XVII international scientific and technical conference “Manufacturing Engineering and the Technosphere at the Turn of the XXI Century”. Volume 3. – Donesk: DonNTU, 2010, - p.122-124.

#### **4.5. Taking into account of the cognitive thinking type in distance education**

**P.V. Stefanenko, S.G. Dzhura, S.A. Isakov**

*An attempt to put forward the theoretical basis for the necessity to transfer from the traditional distance learning to the distance learning with the application of the artificial intelligence is made in the paper. The fourth spatially-time model – a cognitive one is developed. The example of practical application of this trend is given.*

**Introduction.** Distance learning is widely used in the world to transfer the technological way of thinking. It is quite difficult for the development of the creative potential. The distance learning does not take into account the emotional state of the trainee (which is always taken into account at the work with the real teacher) which is one of the most complicated moments in the process. The paper is aimed at improving of learning and choosing of the maximum acceptable trajectory of the user with taking into account the emotional component and thinking type of the student

We have already discussed the pedagogic aspects of the information technologies at the current noospheric development stage /1/ and tried to define the outlook of application of the artificial intelligence in the distance learning /2/. The problem is that it is extremely difficult to reproduce the “spirit” of the subject-matter and not only the technology in the distance learning. That is if we speak about the subject-matter as art and a technology only the latter is subjected to the current distance learning. Only man is able to control education and art so far. We would like to widen the



frames with the help of artificial intelligence technologies. For this we need to understand the models as stages of the material description.

According to the paper in which the artificial intelligence was examined /3/ there are four spatially-time models of painting (it can be applied to any science that can be described). They are real, conceptual, perceptive and cognitive ones. The real one concerns the things that are really planned to be transferred. The conceptual model concerns the things that a teacher wants to say (an idea). The perceptive model concerns the things that the user was able to understand. And the cognitive one concerns the solid residual between the conceptual and perceptive ones. It is also called the training one. The paper is aimed at examining the cognitive model.

The operations made by man with the help of the computer is the continuation of the classical goals of engineering psychology with the exception of the fact that new problems were of cognitive, communication and interactive character that had not been examined in engineering psychology and helped promote engineering psychology in this direction.

Ergonomic research emphasized the link between the work conditions and the phenomena that cause stress such as routine tasks, a sedentary position, visual perception of visual images on displays and many others that were not considered interrelated.

**Cognitive style.** (from Latin *cognitio* – knowledge and Greek *stylos* – a pen) is a term which is used in cognitive psychology and designates steady characteristics of what different people think, how they perceive and remember information and which way of problem solving they prefer.

The cognitive style usually differs from the cognitive ability or level. The latter is measured with the help of intelligence tests. There are disagreements in the meaning of the term “the cognitive style”. However, the term “cognitive style” is widely used in applied psychology (in business and pedagogic psychology the term “cognitive style” has a synonym which is the “teaching style”).

The concept of the cognitive style was first ever used by A. Adler to denote the personality characteristic which is steady individual peculiarities of cognitive processes that predetermines the usage of different research strategies. It was understood as originality of the personality life structuralized by goals and their achievements.

G. Allport considered the cognitive style to be the integral system of the personality of the development order (the ways and means to achieve the goals). Further on the problem was studied by K. Stadner and G. Witkin.

In the former Soviet Union the problem was studied by V.A. Kolga (Estonia), Teplov- Nebylitsin (Moscow), M. Kholodnaya (Kiev-Moscow), A. Libin and others.

About 10-15 cognitive styles are popular and many of them correlate with each other and the difference in terminology is caused by different authors' approach to the problem. These styles are as follows:

- field-independence- field dependence;
- concreteness- abstractness;
- equivalence narrow-wide range;
- category narrowness- width;
- rigid- flexible intelligence control;
- low – high tolerance to non-realistic experience;
- focusing- scanning control;
- smoothing – concentrating;
- impulsivity- reflectivity;
- cognitive simplicity – complexity;
- others (scales of Myers-Briggs tests, NEO PI-R, etc.).

**Cognitive psychology** is a part of psychology that studies cognitive processes in human consciousness. The research that is carried out in the field is related to the issues of memory, attention, feelings, information presentation, logic thinking, imagination, ability to make a decision. Many points of cognitive psychology make the basis of the modern psycholinguistics /4/.

According to the cognitive-information approach of cognitive psychology the gap between biology and human physiology from one hand and between human psychic and thinking from the other one is not insurmountable if mental events are identical to neuro-physical ones that take place in the brain such as the coded pattern due to which some neuron groups are electrically discharged. In this case mental and psychological processes have a reliable material and physical basis due to which the mental essences can be considered not as just neuron electric and chemical activity and their complex interaction, but as a result of perception,

structuralizing and processing of the cognitive information made by the human brain. Neuron network new models based on the principle of the information parallel and distributive processing reproduce such mechanisms of the brain functioning discovered by neuro biologists as interim “hidden” layers with a higher degree of adequacy. The layers take part in inner processing of the signals coming from the outside; help groups of neurons joined in a certain way change their characteristics when new information is obtained. According to the models consciousness, clever thinking and memory are characteristics of the neuron networks and the system as a whole, but not the characteristics of its separate elements /5/.

The thinking process interpretation as that of cognitive information processing is sure not sufficient to give the adequate universal interpretation of all phenomena of the human psychic and mental world. It is hardly able to say anything intelligible about a soul, theophany etc. But it is able to give experimentally proved and satisfactory explanation of many cognitive mechanisms and human cognitive system functioning. This interpretation allows taking a new view of the human biological evolution, analyzing culture as a special information system that includes knowledge, beliefs etc.

**The project implementation.** We examine two cognitive models of a student (that is two thinking types – logic and figurative). To define the predominant thinking type of the recipient the registered user is proposed taking a psychological test followed by recommended lecture text, questions and examples built in accordance with his thinking type. The user can find a more preferable course himself, without taking the test. The development was made by electrical engineering students of DonNTU S. Isakov, S. Panov, and E. Strukovski. The project was practically coordinated by Dr. S. Dzura, and strategic control was made by Prof. Stefanenko. To take the project test address <http://dist.agni-age.net/>. The project is done on the open platform Joomla and continues the hardware philosophy which is supported by the future open community WEB 2.0.

**Conclusions.** The application of the cognitive model in distance learning is grounded in the paper. The authors think that after testing, getting responses and comparison of the model with the traditional distance learning a new landmark in the development of the distance learning with taking into account the user’s cognitive thinking type will appear.

However, there are some difficulties the main of which is that a teacher can not be totally substituted.

#### References:

1. P.V. Stefanenko, S.G. Dzhura, A.A. Chursinova. Opportunities of Application of the Artificial Intelligence in Distance Learning // Proceedings of the XIV international scientific and technical conference “Manufacturing Engineering and the Technosphere at the Turn of the XXI Century”. Volume 4. – Donesk: DonNTU, 2007, - p. 8-13.
2. P.V. Stefanenko, S.G. Dzhura, A.A. Chursinova. Eurointegration through the Distance Learning with the Application of the Artificial Intelligence // Proceedings of the international scientific and methodological conference “Eurointegration of the University Education on the Way of Creation of the Knowledge Community”. Alchevsk: DonSTU, 2007, - p/ 236-245.
3. E.Y. Kandrashina, L.V. Livintseva, D.A. Pospelov. Presentation of the Knowledge on Time and Space in Intellectual Systems. – M.: Nauka, 1989.
4. I.P.Merkulov. Scientific Progress: Cognitive and Social and Cultural Aspects. – M., 1993. - 197 p.
5. I.P. Merkulov. Cognitive Evolution.  
<http://ru.philosophy.kiev.ua/iphras/library/phnauk2/SCIENCE4.htm>

### **4.6. Distance education energy and information paradigm**

*P. V. Stefanenko, A.V. Levshov, S.G. Dzhura*

*The fractal, polytomic, and creative paradigms of the education development as well as knowledge hierarchy are analyzed. The hypothesis of the new approach to the distance learning based on the energy informational pedagogic paradigm and the approach to ethic algorithm construction and awareness is proposed.*

**Introduction.** The development of the civilization is accompanied by a serious problem of lacking behind as to comprehension of the changes taking place in the informational post-industrial society. This leads to a number of unreasonable risks. It is very important for the people who write about it to be good at not only philosophy but also at engineering science. Besides, the process is to be reciprocal. Musical drugs and traditional challenges to modern times can be mentioned in connection with it. The paper is aimed at understanding the key problem necessary to solve the issue which is the application of the distance learning new energy and informational paradigm and solving of a number of interim and extremely important related problems. The new concept of the ethic algorithms discovered by intuition as the interaction between a human being and the space is introduced.

At present science is very active as to the new paradigm search. There have been scientific revolutions in some sciences (astronomy, physics). The scientific revolution in archeology is about to come/1/. The attempts to summarize the approaches were made in the papers /2, 3/. Thus the answer to the question about possible paradigms was as follows: “If the idea does not seem absurd at the first moment, it is no-win”. (Albert Einstein).

**Fractal paradigm:** it has every good reason to come back to homogeneity of Anaxagoras and monads of Leibniz affirming isomorphism of the little and the great which is alternative to mechanicalism where a part speaks briefly about the whole. Now it will say Everything. .

**Polytomic paradigm:** it will operate by more complicated schemes instead of the traditional dyads and triads. It will be asserted in ontological pluralism. This will not mean the cancellation of old dichotomies and trichotomies. We will rise to the new level which requires the multiple approaches.

**Creative paradigm:** it considers Nothing to be the world’s basis and proposes to deal with the development of the methods of its stimulation. The highest aim of theosis is to learn to create something out of nothing; Obscurity ontology: philosophy will inevitably lead to the necessity of its recognition.

Science per se is on the threshold of the synthesis of science, religion, and philosophy.

**Coming synthesis.** Science, religion, and art have searched it for a long time. Patriarch Kirill says: “Holy Fathers have combined scholarship and theology and formed a synthesis. Famous theologian archpriest George Florovski called it patristic synthesis. He had been dreaming of creation of

the new patristic synthesis. He wanted the modern generation of theologians to learn to combine the outer secular culture with the theological creativity for the theological creativity to be able to enrich this culture, for the words of Church to be topical. I pray and hope for the dream of George Florovski to come true inter our vivo”/4/.

One of the most outstanding scientists of the XX century, a historian of science and a philosopher V.I. Vernadski said: “The scientific outlook is not synonymous to the truth as well as religious and philosophical systems are not the truth either. All of them represent only approaches to it, different demonstrations of the human spirit”. According to him ‘as Christianity was not able to fight the sciences in its sphere but gave a profound definition of its entity, the science will not be able to break Christianity or any other religion in the sphere which is alien to it, but will be able to define and comprehend the forms of its vision.”

Here is the attitude of science: Andrey Dmitrievich Saharov in his Lyons lecture said that science is characterized by three interrelated features: aspiration to comprehension and creativity, practical significance, forming of the unity cementing the mankind. The virtual reality technology provides intellectual poly-sensor communications with the subjects (objects, phenomena) of the virtual world from different points of view and gives the user the possibility to form and analyze the options of the cultural international distant exchange and has the most important function of the science development /5/.

Alfred Schnittke agrees with him: “The ordinary, trivial mind looks for the problem solving in its plane. It creeps on its surface bravely till it finds the way out by the accidental trial and error method. The genius mind searches its solution converting it to the universal level where there is a good observance of everything and the right way is vivid. That is why those who save their time for one matter always get less than those, who deal with related matters”/5/.

In fact this is the synthesis N.K Roerich spoke about: “An ignorant person is to become civilized first, then educated and refined, and then sophistication and **synthesis comprehension** come, which is finished by the concept of Culture”/6/.

The mentioned synthesis is artistically represented on the World’s Banner- three circles in one circle. S. N. Roerich interpreted the symbol as religion, science, and culture in the circle of culture kept in hands of Madonna in the painting of N.K. Roerich “Madonna Oriflamme.”

D. I. Mendeleev said: “There will be the day when all the world will be enveloped by the single science, single truth, single industry, single brotherhood, single friendship with the nature”/7/. This means that the

single proved theory approved by the religious and atheists, scientists and all the people is to be adopted.

**Educational energy and informational paradigm.** What about education? One unprecedented step has been made in this direction recently. The energy and informational paradigm was developed (see paper /8/). It was absolute revelation for the author of this paper as he, as many other people, had been waiting for the book to appear for a long time.

The volume of investigated literature is impressive, the book style inspires, and the proposed synthesis commands great respect. I think many of us had been waiting for the text-book, and here it is. The following approach is proposed in it /8/: “The truth is, as usual, between the extremes. Science, if it wants to explain the essence of things in a right way, should use both dialectical and metaphysical approaches, and, to be exact, to give up extremes and chose one dialectical-and-metaphysical approach as the basic one. It is extremely important for the human-being sciences in which the main part of the factors has not been explained and systematized. It’s time the pedagogic, as one of the main human-being sciences, gave up the “only right” dialectical approach and adopt all the best from the metaphysical method. As we understand now, it is impossible to comprehend a human-being with dialectics only: there are too much in him which can be checked or analyzed with the help of mathematics. We will move further on only if we combine the dialectical and metaphysical approaches.

Metaphysical, sacral, and esoteric (secret) knowledge has been considered a fruit of the under-developed mind for a long time. The official science was positive to isolate itself of the knowledge. When the information on mysterious and incomprehensible events appeared in the printed media, an official scientist was quick to give a comment which revealed the mysticism and delusion.

Today it is impossible to brush the alternative knowledge aside. It multiplies and forces the official one out. It agitates the minds and broadens the boundaries of the cognized. It is topical and needed. It is necessary, at last, as helps a modern person to better understand our many-sided world and find his place in it”/8/.

The paper offers a hypothesis of a new approach to the distant learning based exactly on the above-mentioned paradigm of energy-and-informational pedagogic.

**Noosphere education.** This type of education has been proposed more than once. By its essence it is the education of the ionosphere stage of the mankind’s development. See, for example, /9-11/. What does the noosphere mean? “Noosphere is the field of life controlled by the intellect” according

to V.I. Vernadski. According to the concept of the energy-and – informational pedagogic it is “fused radiation in the shape of energies consisting of the finest material particles forming a cover around Earth which is called the world of fine energies. Astrologists call it the planet astral field.” Is it one and the same thing? There is one more concept of Egregor. Here is a citation from Wikipedia (the biggest encyclopedia in the Network): Egregor (Old Greek ἑγρήγοροι, «guards») — means the soul of a thing, “mental condensate” born by people’s thoughts and emotions and getting the independent existence. Egregor is the informational substance. From the point of view of bio-energy-informatics “Egregor” is the energy-informational-time structure which appears under the co-directional actions of a group of people having common desire. There are different egregors: religious, family, tribal, clan, those of magic orders, some philosophical doctrines, creative schools, purposeful teams working for a long time, social movements, etc. Thus, the concept is very close to that of noosphere if not just the same (only explained in terms of traditional science).

Egregor and individuals mutually develop on a constant basis in the frameworks of this integration of people due to the exchange of information and energies which helps to speed up general development of the collective mind.

In general, egregor can be characterized as a certain result of the thoughts of the group of people acting independently on each of its members and, possible, of the group as a whole. So, we suppose that egregor is a part of noosphere. There is egregor of Christianity, Buddhism, Ukrainians, all the earthlings.

**Noosphere problems and those of the Internet as the noosphere prototype.** Knowledge without moral sense is a sword in the hands of a crazy person. We understand it but don’t move further on. The above-mentioned synthesis is of great importance here. It was St. Palama who said: “The mind which gave up God becomes either bestial or demon like.” Is not it said about the Internet? The answer is both-“yes”, and “no”. The oriental approach different from the machine binary logic is to be applied here. The Director of the Institute of Oriental Studies academician B.R. Rybakov said that this and that could be said about India, and this will be right. But absolutely different thing could be also said, and this will be correct too. In our case it depends on where we apply it to. We can prove that the Internet works against man in 80-90% of cases ( on the traffic) and only a small part of resources does good to man, works for the evolution, that is goes in the direction of noosphere.

**Machines as slaves (the informational century slavery).** Man has shifted his problems on the shoulders of other people for a long time. The



slavery started in such a way. You can buy or sell a slave, find out a bomb composition, both sites of different perversions and those of museums, universities, and libraries through the Internet. But it appeared that man must not be exploited, an animal must not be exploited to a less extent, but a machine- can be. Are we right? According to esotericism the sense (of engineering philosophy) is man's support. We can do everything without machines, but in this case he does not develop himself (in the West), and looks for happiness outside, though the happiness is inside. Holy Scripture says about it. If we go on like this, we will become cyborgs/12/. Did the mankind want exactly this? Этого ли хотело человечество? Alas, but a picture in the book "Man's Upgrade" speaks directly on the contrary. The matter is that the problem of existence of the inanimate nature in the light of the coming synthesis could hardly be considered closed.

**Accumulation of the badly learnt knowledge.** Every year knowledge increases twice. Was it the Internet great Plato was talking about: "Absolute ignorance is not the greatest evil: accumulation of the badly learnt knowledge is worse". If we did not sleep and eat, and could read at a huge speed, we would not be able to read all books published in the world. What shall we do? We should develop the strategy which will answer the question: What should we know to know all the rest? What is the most important thing in the world? What should we do not to waste our life on minor things??

**Life strategy.** The mankind has developed different strategies that exist in philosophical systems, religions, scientific schools etc. What shall we do in the information epoch? Why should we accumulate unnecessary knowledge? The majority of the strategies aimed at getting success in the information epoch are concentrated in algorithms. Let us analyze them.

The evolution in technical systems means the process of constant optimization of biological species where the natural selection is the main directing force /14/.

The evolution theory has influenced the people's world outlook since its appearance. The theory presented by Charles Darwin in his work "Origin of Species" in 1859 started the changes. But Darwin, as well as many of his contemporaries, assumed that the development was based on the natural selection and could not prove many sufficient concepts of his hypothesis. For example, he was not convincing enough to show how the inheritance mechanism should work to support the necessary level of variability. The idea, however, turned to be rather fruitful.

So, it is not a surprise that the scientists dealing with the computer investigations turned to the evolution theory in their search for new solutions and inspiration. The idea of the computer system with the simple

mechanisms of variability and selection functioning according to the evolution laws in the nature systems was rather attractive. This hope caused a number of computing algorithms and systems built on the principles of the natural selection and genetic inheritance.

The history of the evolution computations started with the development of a number of different independent models of the evolution process. There are three main paradigms among them [15]:

- ◆ Genetic algorithms (GA);
- ◆ Evolution programming;
- ◆ Evolution strategies

**Evolution algorithms as the Evolution Laws in esotericism ( laws of Dharmah, Hierarchy, Karma etc.)** This topic was dealt with many times with different level of completeness (see, for example, [16-18]). Here we can't help citing Elena Roerich: "There are a lot of the stopping, but they are unable to stop the "World's Karma flow." The confidence in the righteousness of the construction of the New, in the world's evolution came strongly and passionately into the consciousness of young generations. In fact the fight between the Light and Darkness is taking place. It is the fight for the Light, Common Good, for revealing of the real Knowledge and approval of the Beauty" [19].

«The events will happen unexpectedly, but they will always be in favour of our country. The awful time will spread quickly as purifying vortex. The problem is that many people do not understand the reason and meaning of the events taking place in the entire planet. New consciousness must love the wave of new construction. The new construction must liberate thinking therefore causing good changes. The evil accumulated in the world will be settled by perturbations. But do not be afraid! There is a shield of the Light over the new consciousness which has refused of evil and envy and understood where the evolution flow was rushing. The evil spread will be stopped. The Space Justice will activate new leverages and the world's new karma will start asserting itself" [20].

People are eager to blame the Teachers in resorting to human's injustice while preparing the New World. But let accusers reach the Space Consciousness at least once and reckon with the Space Terms. All the key moments of the mankind's evolution are related to the latter. The Teachers while getting the consciousness of the New World ready think of number of people with new Space Consciousness necessary for the Space Balance being gathered in a certain place of the Earth.

The world's politics and economy have never been and will not be the decisive moments of the evolution. The aim of the evolution is to create not a person who thinks politically correctly, but the person who is

able to think by the Space categories. Politics, economy and all social formations created by them teach a person to know the matter only on smaller and temporary examples. It would be ridiculous to think that “justice” or “unjustice” of these short forms of the person’s social life are the measures peculiar to the Space Intellect. Even the karma of some people and the nation’s Karma are such different values that they can not be compared. Sovereigns direct people’s fates and, as an exception, watch the karma of some of them. If Ivanov had killed Petrov, and Petrov revenged by killing Ivanov, they will go on killing each other until one of them renders good for evil and breaks the magic circle. The seeds of the good are to be grown and gathered, while the world’s evolution ideas, like magnets, are spread in certain parts of the world according to the evolution Space plan. Incarnation of the people able to catch the ideas takes place in these world’s parts [18].

**From evolution algorithms to the ethic ones.** The idea of Ethic algorithms the mankind is to discover is in the fact ancient knowledge (it is difficult to be read immediately as it is coded or, if to say this in a modern language, is a cryptogrammic one). It is dangerous and open to those who change themselves in the process of its studying or makes those who study it for egoistic reasons mad. It is amazing! It is the thing the modern algorithms lack of. It was Alfred Nobel who said: “New discoveries will bring the mankind evil, rather than good.” Thus, the goal of studying and usage is of significance. The following statement of Prof. A.A. Minaev, Rector of DonNTU, and academician of the NAS is very important: “Now many people are good at computers. They are even virtuosos. But not all of them are able to control their own consciousness and sub-consciousness which is the super-powerful supercomputer” /2/ ( from the point of view of the authors nowadays not every person has such a possibility of the potential development which is stronger than any computer in the world connected to the Internet. But the situation will change soon).

**Gaining of the meta-knowledge through the Internet.**

To understand a problem we should move it away. The more the distance is, the better the matter is seen. As we say, the great is seen at a distance. V.V. Pak (the Department of mathematics of DonNTU was called after him) wrote about it. This great mathematician and scientist first spoke about it at the meeting with power-engineering students at the Department of Industrial Companies Power Supply in 1997. There are some pictures taken at the meeting. The administration of the Faculty always created the conditions for the implementation of new ideas and useful unusual innovations. It is not a surprise that it is the Power Engineering Faculty (PEF) of DonNTU that established the workshop with participation of

outstanding scientists of nowadays. The workshop created the growth medium for the ideas and their discussion and later resulted in a number of projects: Moscow inter-disciplinary conference, the University of Culture restored after 50 years of oblivion. By the way, this structure was presented as an additional result of the work at the European grant TEMPUS (JEP-27085-2006) in which the authors of the paper took an active part. The investigations showed that it was impossible to raise the level of economics without the raise of the culture level. The role of the PEF as the founder and leading executor of the project and ideas implementing it is vivid. So, the first postulate is as follows: the more the distance we move away is the more accurate the forecast is. The second postulate was expressed by an amazing Ukrainian scientist G.S. Tesler in “New Cybernetics” /22/: «There two important to us results in the books of Gödel- impossibility of the mathematical argument of consistency for any rather wide system (energetic fits this definition) which includes all arithmetic in the frames of the system, and existence of the principle of limitedness of the possibilities of axiomatic approach. Not a single solution of the arithmetic system can make it complete. Both of these contradictions can be solved only on the basis of meta-theories and met-approach. Though the results are proved for arithmetic they, as it turned out quite often, have common methodological character and can be applied to the systems of any nature » /5/.

**Knowledge hierarchy. What is knowledge?** According to its definition “knowledge is the ordered collection of new characteristics of the subject, world, and their interrelations presented in the form of the particular meta-text. The knowledge does the transformation of fragmented images into the systematized valid form and keeping of all that can be saved, transmitted and developed. **The problem of knowledge, the structure, appearance, specific character of its perception, cognition and out-coming of new knowledge (creativity) is a philosophical, methodological, natural-and scientific, humanitarian and applied problem which is almost the most difficult one» /5/. In this paper we offer the hypothesis of the knowledge hierarchy: information-knowledge-Meta-knowledge.** The usual unstructured information is the basis on which the knowledge (let us call it the applied one or necessary for the everyday life – earning daily bread) is formed. The knowledge from the capital letter is the knowledge that gives a chance to find the way to the Eternity. It is finding of meta-knowledge historically given to the mankind through the prophets and Teachers. The knowledge was obtained through the insight one of the states of consciousness which is being thoroughly examined. Jacob Bohme, a shoemaker, William Blake, a semiliterate engraver, uneducated prophets Ezekiel and St John the Theologian with his frightening Apocalypse the

uneducated person K.E. Ciolkowski after whom the Scientific Academy was named had the insights like that. Let us also recollect Edgar Cayce and John Keely /23/. This is the way of cognition of all outstanding people as well as the energy of all the times and nations of Nikola Tesla. “The Space models the face of the Earth”, - said V.I. Vernadski the portrait of whom is in the office of DonNTU’s Rector.

**Meta-energetic.** We have written about the phenomenon of N.Tesla in the proceedings of PEF several times / 24, 25/. He was not the only one among the engineers. John Keely /26/ was a genius in mechanical engineering and had his own unique as to its inner essence principle which allowed him to direct and control the energy of the special air. He succeeded in bringing it down to the earth more than any of the mortals living in his century though he was not initiated into the final Mysteries. Though his devices worked on the air force, Keely’s own psychic energy of the inventor was the “trigger” putting it into action. **The achievement must be considered the prototype of the far destined to the mankind possibility to get the energy not from the planetary interior but from the Space depths.** That is why John Keely and N. Tesla can be called the Messengers of the Future. An ordinary person is keen to know why this cannot be repeated now. The answer is as follows: “The representatives of the modern Fifth race who are too deep in the substance were not allowed to use (especially on the commercial basis) the spiritual spatial energy as because of its limitless destroying and creative power they can expose themselves and other people and the life on the planet to danger» /27/. N. Tesla actuated the air out of which he got the energy for his engines in some different way. This is a complicated and delicate issue. Whether the mankind will pass from the usual energetic to the meta-energetic (the term is introduced below) which is the nonfuel ecologically pure energetic of the future depends on its solving. Many people living on the Earth planet dream about it. It is real. According to history the ideas and inspiration for technologies were got from science fiction. The majority of them are implemented into products (flights to the Moon, robots, the submarine, the Internet) etc.

**PEF and DonNTU’s contribution to the meta-knowledge understanding.**

We wrote about it at the beginning of the paper. It was absolutely vivid in 2008 when one of the representatives of the PEF was working at the Internet resource devoted to the perception of this meta-knowledge. He was doing it under the supervision of the Head of the Department, Dean, and staff of DonNTU. First the material was accumulated and discussed at forums and different related projects. There are more than twenty of them.

The history and scientific explanation to it are given in the paper /28/. The project work started in 1991. In 1997 within the project Oriflamme <http://roerich.com/> the electron library on the synthesis of science, religion, and philosophy was noticed in the network. It got Ukrainian awards and some international ones (in 2008)/9/ that proves the recognition of the meta-knowledge itself. International experts called it the best world project of 2008 related to the synthesis of religion and philosophy. It was awarded an international diploma in the nomination “Keeping of the Roerich’s Heritage”. The diploma was handed in to a representative of the PEF in the Hermitage. The procedure was carried out by the chairperson of the world-wide known club of the residents of St. Petersburg Michael Piotrowski /30/. There is no doubt this is the merit of the staff of the Department, Faculty and University. For the awarded person it is a huge advance and motivation to work, he so called future support. This work is the contribution into understanding of the idea of the library.

**Knowledge of all the mankind.** The project “Oriflamme” is the implementation of the ideas of the scientists from St. Petersburg /31/: “Knowledge from the point of view of a separate person is the information on the possible results of the future process in which the given person will take place, on probability of implementation of favourable and unfavourable results, methods, and means of influence on the probability. There are a considerable number of elements of the knowledge of some people that can be good for all people or the majority of them. This knowledge can be considered the knowledge of the mankind. As all people are interested in it, it should be organized to solve three tasks.

1. Maximal (free) access to the knowledge for practically all people through books (libraries), newspapers, radio, television, newsletters, Internet, Synergonet. With these means the survival of some people and the mankind as a complicated self-organizing system is increased.

Any man-made structure, which prevents the knowledge dissemination through the force, financial limitations, and false information, only worsens the mankind’s future and, therefore, some of the quanta. From the point of view of the mankind as a wave it is a criminal one. This idea can be the criterion of criminality and totalitarianism of different regimes irrespective the level of democracy they think they have. One of the main, and may be the most important criterion of the power criminality is not only the number of people killed by the power, but also the amount of the general knowledge of the mankind which was not disseminated to all members of the society *free of charge*.

2. Provision of worth-while life to all people taking part in getting and disseminating of the knowledge necessary for the mankind’s survival as an

entire wave. It is a problem of the material and informational existence of scientists, teachers, journalists, cultural workers and religion figures. We think of the meta-knowledge as far as our terminology is concerned. It is partially implemented in the Oriflamme project carried out and supported by the PEF of DonNTU.

**The meta-knowledge examples.** Here are some quotations about the future of power engineering and the society itself implemented in other spaces of the objective reality. “We have no factories, machines, and plants. The spirit apparatus has replaced them. We have all people need. The Earth gives birth in abundance and the people have everything to cater their bodies. They have to work much and hard. They work physically to keep fit. The main sphere of their work is the field of thoughts and subtle energies. The forces of nature and the element are under the human’s control and subdue the people completely. The forces are powerful and inexhaustible. The space gives everything the mankind needs in the sense of **energy**. You work so hard to get a new type of working energy. Fire energies are in man’s service and are used with the help of man’s microcosm. **We are close to implementation of the great task- to arm the mankind without any device.** The Life Fire Doctrine is common for all the inhabited worlds, and the fruits of the Highest Knowledge are widely used here. I inform you, the earthlings, about it for you to know the main direction of your mankind’s evolution and the life forms implemented by us could be desired and reachable on your Earth planet...”/32/. About science: “Our sciences differ greatly from yours as they are based on the Concealed Knowledge of the Space Laws common for all the Worlds. The Concealed Knowledge which you have on your Earth differs from the official science because the latter, being very young, has a blind approach to understanding of hidden nature forces and secrets of the essence of man’s microcosm. It denies much because of its ignorant self-importance. That is why it is one-sided. With us the real practical knowledge and the Life Concealed Doctrine are combined and the Space Secrets and those of subtle energies are in our service in the current life” /32/. The conclusion is like this: “Not dreams, fantasies, groundless imagination but the indisputable knowledge of the spirit will bring you to the depth of the Space and Far Stars. You are to comprehend the space way of man. You can’t do it if you don’t know the Far Worlds which are given to you as a prototype of your further achievements, as the leading force, the goal...” /32/.

**Interim conclusions.** We cite the meta-knowledge fragments which are to be decoded for us to understand how the engines of Kelly worked, how N.Tesla transmitted energy without losses and planned to

supply Earth with nonfuel and ecologically pure energy (all this is understood by the energy-informational concept). The task is worth working at even though the fact itself seems impossible as impossible was everything the fantasists had written about. Sooner or later all became a reality. The main thing now is for the mankind to deserve the Knowledge it faces. Ethics is the main criterion or the safety measure to communicate with the meta-knowledge. Thus, the task is as follows: **to develop and comprehend ethic algorithms of the universe. “The knowledge is related to obligation and responsibility.** The responsibility for the gained knowledge is big. The knowledge is given not in vain and not for fun, but for its strict **application** in life” L.D. Landau spoke about it: “There are natural, unnatural, and supernatural sciences”. We think the ethic algorithms belong to the super-natural ones.

**Distance learning at a new stage.** The conclusion that the trainee is to be as close as possible to a trainer is based on the energy-informational paradigm of education/8/. The Skype technology when the trainee and the trainer see each other on-line is the most convenient today. But the energy of one does not meet the energy of the other in this case. There is only video and sound contact, which is good, but not enough. If to use the energy-informational terminology, their auras are not in contact. In fact, the atmosphere of a scientific school is the catalyst of the scientific activity. Perhaps, the compilation of the teacher’s energy fields should be added to the on-line compilation. However, it also looks poor as engineering supports the man who has not discovered his inner reserves yet (more than 95%, - see /33/). The evolution role of the engineering is to show people which opportunities they have – to transmit a thought and picture on a distance (a camera and TV-set) etc. Person’s aura was in Russian dolls. We can speak about the aura of premises and people. As soon as we come into it everything goes on itself. People in the premises and groups start to understand the things which they could not understand earlier. Common knowledge (horizontal-to earn life, but not vertical) can be transmitted on a distance. To have deeper understanding a person should go a long way to find his Teacher. There is an oriental saying: “The teacher comes when the pupil is ready”. When they find each other, it is great happiness for both of them. The Verges say: “Seek for the Teacher’s closeness in the spirit. It is accessible in the spirit. You can rise with your spirit, raising your body and making it refined. As a balloon raises a basket with ballast the spirit, if it is high, raises its shells. The spiritualization of the physical, astral, and mental substance by the spirit fire takes place. The goal of the evolution is to spiritualize, rarefy and refine the Earth and its physical and earthy spheres,



and transform the rude into the spiritual and fiery”. It is a super-task, the so called distance learning of the future, though the new is the well forgotten old. It was like that earlier. The traditional approach to the education is to get a book (journal, brochure, film). It is not a problem in the era of information, and knowledge tends to be accessible (open libraries, noosphere library project). However, the problem is in the knowledge getting. The real (vertical) knowledge is coded that saves it from ignoramuses. The Bible has seven keys. If you do not know them, you will not be able to understand it in full size. You will do it according to the ethic level allowed by the ethic algorithm. But there are bypass (temporary) maneuvers. It is when because of a number of circumstances a recipient gets the knowledge and uses it for mercenary ends. This process has been called black art from the earliest times. The retribution will come as the space laws act both on the earth and outside, and not only in a current life, but in the future one. The birth of monsters is explained by this. There were problems not only with their parents (sometimes rather decent people give a birth to monsters). This can be accepted as a hypothesis. The future distance learning can go two ways. The first one is traditional for engineering- perfection of the outer (computers, communications, software); the second, the oriental, one -perfection of us. The Teacher will come on time to those who knock. Let us illustrate the idea /32/: “The strong desire to get particular knowledge predetermines its obtaining. Any strong legal desire comes true with our help very quickly. We gain assistance to everything related to the Common Good”.

**Conclusions.** Today the innovative approach of the energy-informational concept (or paradigm) of the education development is the crucial one /8/. Different educational technologies, distance learning in particular, can be developed in the frameworks of the concept. The mankind will have to realize and to know the universe ethic algorithms which are outlined in the paper as the ways to develop the trend. Perhaps we will not need machines soon and come back to the life simplicity. We will learn a technocratic lesson (we will improve not the outer, but the inner) during a new round of the mankind’s development. We will not need the distant learning as “a pupil is ready when the Teacher comes”. This can happen in any entity space, not obligatory near the computer. The following is said about the simplicity: “The simplicity of phenomena is usually not open to people. The great laws of life are too simple for the people to accept them without strolling outside. All great is simple. As far as the simplicity is not peculiar to people, the great is not open to them. Communication in the spirit and with the help of a thought is easily accessible. But who will believe it? How many years did you need to dare

to approve a contact with Guru? The wheels of thinking are very slow as there is no simplicity...”/32/ We will assimilate the **“new” method of knowledge getting to which the evolution prepares us**: “...Man faces a mass of the most interesting findings: the whole world is open for cognition. But it is done not through the brain. Communication goes through the heart. The heart grows and refines being deepened into this fine work. Develop the knowledge of your feelings. The knowledge comes to the open centres through feelings and reaches consciousness. The spirit knows much. The knowledge of the feelings and that of the spirit are inseparable. Both mean direct knowledge without interference of the brain. When the consciousness is concentrated on getting the direct knowledge, it gets it if the brain is not let into the process. The brain plays the sub-utility role of registration of the facts coming into the consciousness. But the getting passes by. The knowledge of the spirit and that of the feelings is a new method of obtaining of the knowledge for the refined consciousness and of the information a person is interested in”/ 32/. We will not need ordinary libraries as we will start using the natural ones. All knowledge is known to be in the noosphere and can be extracted directly from it. This will be a new stage in the mankind’s development. Esoteric sources open to people today in such a generous way show the way there.

#### References:

1. M. Baigent. Forbidden Archeology. – M.: Exmo, 2004.
2. Y.V.Linnik. Sketches about a New Paradigm// Delphis, №3 (59), 2009. - p. 41-46.
3. E.V. Zorina. Paradigm of Scientific and “Non-scientific” Knowledge (Thoughts at the Front Door of Science), Delphis, №3 (59), 2009. - p. 47-51.
4. Speech of Patriarch of Moscow and All Russia Kirill in t he Kiev-Pecherskaya Laura <http://patriarh.in.ua/uk/node/421>
5. D.I. Shapiro. The Virtual Reality and Neurocomputing Problems. – M.: RFK-Image Lab, 2008.
6. A.P. Kovalev, V.V. Otkidach, S.G. Dzhura. Heading to a New Syntagma // Wisdom of Earth Home. About the World Outlook of the XXI Century. Edited by S. Dzhura, V. Yankina, A. Kazanski. – StPb-Donetsk, 2007. – p. 160-169.

7. Y. Urmantsev. Nine + One Sketches about System Philosophy (Outlook Synthesis). –M.: 2001. [http://raen-noos.narod.ru/lib\\_urmancev1.htm](http://raen-noos.narod.ru/lib_urmancev1.htm)
8. I.P. Podlasni. Energy and Information Pedagogic (Text-book). – M.: Data Square, 2010.
9. V.S. Lysenko. Noosphere Pedagogic Contours. <http://torrents.ru/forum/viewtopic.php?t=1574669>
10. N.V. Maslova. Noosphere Education: Methodology, Technology, Tools. <http://raen-education.webhost.ru/b-masl3.htm>
11. N.A. Bezzubtseva. Noosphere Education: from the Past to the Future. <http://elibrary.ru/item.asp?id=9925865>
12. V.A. Zubakov. Wisdom of Earth Home (about the World Outlook of the XXI Century). StPb, 2003; <http://www.roerich.com/zip2/maneb.zip>
13. V.V. Yemelyanov, V.V. Kureichick, V.M. Kureichick. Theory and Practice of the Evolution Modeling. – M.: Fizmatlit, 2003. - 432 p.
14. A.V. Nazarov, A.I. Loskutov. Neuronetwork Algorithms. – StPb.: Nauka I Technika, 2003.
15. V.N. Bondarev, F.G. Ade. Artificial Intelligence. – Sevastopol: SevNTU, 2002, 615 p.
16. A.I. Klizowski. Basics of the World Understanding of New Epoch. - [http://www.roerich.com/zip/os\\_mirop.zip](http://www.roerich.com/zip/os_mirop.zip)
17. A.A. Makarov. Great Laws of the Space //Delphis, №3 (43), 2005.
18. P.F. Belikov. The Roerich Family. Spiritual Biography Experience. <http://www.roerich.com/zip/belikov.zip>
19. E.I. Roerich. Letters. Volume 2. – M.: MCR, 2000.- [http://www.roerich.com/zip2/ei\\_2.zip](http://www.roerich.com/zip2/ei_2.zip)
20. E.I. Roerich. Letters. Volume 1. – M.: MCR, 1999.- [http://www.roerich.com/zip2/ei\\_1.zip](http://www.roerich.com/zip2/ei_1.zip)
21. A.A. Minaev. Speech in Front of Master's Students. – Donetsk: Donetsk Polytechnic, №14-15.
22. G.S. Tesler. New Cybernetics. – K.: Logos, 2006. – 2004. – p. 57-58
23. L.N. Melnikov. The Virtual Reality and the Space Consciousness // №2 (46), 2006. – p.111.
24. A.P. Kovalev, S.G. Dzhura, L.V. Chernikova. Energy Risk Control (to the 150<sup>th</sup> Anniversary of Nikola Tesla) // Proceedings of Donetsk

- National Technical University. Series: “Electrical Engineering and Energy”, issue 112. - Donetsk: DonNTU, 2006. – p. 151-153.
25. A.V. Levshov, A.P. Kovalev, S.G. Dzhura. Heading to the Clue of N. Tesla’s Phenomenon (Interdisciplinary approach) // Proceedings of Donetsk National Technical University. Series: “Electrical Engineering and Energy”, issue 7 (128). - Donetsk: DonNTU, 2007. – p. 11-13.
  26. T. Pimans. J, Keely as the Founder of Free Energy // Delphis, №2 (42), 4(44) 2005; №1-4(45-48) 2006; №1 (49), 3(51) 2007; №2-4(54-56) 2008. <http://www.roerich.com/delfis/index.html>
  27. E.P. Blavatskaya. Secret Doctrine ( in three volumes) – Kharkov; Exmo Folio, 2008 <http://www.roerich.com/zip/td1part1.zip>
  28. S.G. Dzhura. Social Aspects of the Internet Communications// Proceedings. “Language and Culture: Problems of the Social Communication and an Intercultural Dialogue”. Supplement to the inter-disciplinary practical newsletter “Man in the Social World”. Volume 6. Tula, 2003. – p. 42-51.
  29. Oriflamma project awards: <http://roerich.com/award.htm/>
  30. T. Davidenko. Let the Good in, and it will Come Back // Vecherni Donets, №166(8798) of 11.11.08; [http://iic.dgtu.donetsk.ua/russian/ovs/don.jpg /](http://iic.dgtu.donetsk.ua/russian/ovs/don.jpg/)
  31. M.A. Basin, I.I. Shilovich. The Way to the Synergonet. – StPb.: Norma, 2004. <http://www.roerich.com/zip3/synergonet.zip>
  32. Sides of Agni Yoga, 1957. – Novosibirsk. Algim Company. 2008. 2008. [http://www.roerich.com/zip3/grani\\_57.zip](http://www.roerich.com/zip3/grani_57.zip)
  33. V.D.Pekelis. Your Abilities, Man. <http://biblioteka.teatr-obraz.ru/node/7489>

#### **4.7. Synthesis pedagogic fundamentals**

S.G. Dzhura

*The hypothesis of introduction of such a new pedagogical conception as the “synthesis pedagogic” which in its turn is based on the evolution, energy informational and metapedagogic has been examined in the paper. The latter is an unachievable peak which is to be understood further on.*

*The global criteria of the pedagogic targeted function as to the electrical engineering specialities were worked out.*

**Introduction.** The synthetic conception of pedagogic which is based on a number of sciences cannot ignore recent discoveries made in other fundamental sciences (the discovery of God's particle - Bose particle - in physics, for example). The common breakthrough of the world science requires certain corrections and the vector of the development of pedagogic of our country.

The basics for transformation of modern pedagogic and the prospects of merging of its main trends are as follows:

Sooner or later the pedagogic leading trends flow together like rivers do. As far as it is impossible to repeat the experience of the world and native pedagogic coryphaei for certain and we can only follow the directions the mightiest of the science have shown, let us analyze the pedagogic present state. The general world crisis could not help influencing pedagogic too as the science is to find the way out first and foremost, as it is to give the knowledge which will be in demand and will be able to take the mankind, country, branch out of the crisis, which is systemic according to many assessments. Pedagogic itself also requires the system analysis. According to S.U. Goncharenko /1/ the analysis is to be done with the inter-disciplinary approach which leads to synthetic pedagogic being discussed below.

**Analysis of the problem.** The analysis was done in the paper "Philosophic Approach to the Analysis of Modern Pedagogic (Relative to Ukraine) /2/. It reads as follows: The modern state of education is reflected in pedagogic – both in theory and practice –and is implemented according to its laws, principles, methods, and ways. It is a problem polyhedron. Its analysis allows beginning with the main problem (pedagogic goal), the ideals of which in our opinion are not in demand at present" /2/. It is shown and proved that modern pedagogic fulfills only a utilitarian function of service of the society which gives it its social order. That is, it is a guided one by its matter though its main function is to search the truth and be the leading one (but not the guided!) and lead this civil society to the Truth. That is, riders have exchanged their places and now the lower is trying to rule the supreme. This can't last much longer. This is an outlook problem which is a source of the outlook crisis. The society is moving on the wrong direction and the following statements illustrating the situation are topical and prove this thesis: "The world policy and economics have never been

and will not be the crucial moments of the evolution. The goal of the evolution is to create a person able to think in Space categories but not the one who thinks politically correctly. Politics, economics and all social formations created by them teach the person to know the matter only small and temporary examples. It would be awkward to think of the “justice” or “injustice” of these short-lived forms of the social life of any person as the criteria which are inherent to the Space Intellect” /3/. Its importance is in the following: the more the country implements its evolutionary sense, the closer to the evolutionary development of the mankind it comes (the evolutionary pedagogic partially originates from this). The countries which do not implement their evolutionary sense disappear from the face of the earth. Here is the indirect, and for the majority the main, proof of the above mentioned: “The Space Evolution takes its normal course. The attempts made by the darks to stop it are unsound. The Earth is a special case meaning nothing for the Limitness. Every earthman joined the Evolution is included into the world life course. The one, who is against the Evolution, dooms himself to regress and destruction. The Evolution wastes go through the agonizing stage of decomposition. You cannot go against the Evolution for a long time and be unpunished. It is better to join it. The fate of some people, whole nations, and even races that do not meet the requirements of the Evolution is awful. They are just swept from the life arena. The degeneration and decomposition can last for centuries. We know the leaving races and formerly great nations that now are nobody. The Bushmen and Australians are the remains of the formerly great races. It is better to join the Evolution firmly. It is not limited by the Earth only. The road along the stars is wide and endless. The travelers going along the endless road often are not aware of their destination. The destiny of the person is great, but it is to be realized. Otherwise we can miss the most important” /4/.

The problem of the science to lose its main goal was emphasized by the Candidate of Psychology L. M. Gindilis /5/ that retraced the stages of science formation and paid his special attention to the values research should have had when experimental natural science was being formed. These are universalism, collectivism, disinterestedness, organized skepticism. From the second half of the XX century science became an appendage to high technologies, and the values of research faded. Unfortunately, profit, business, a social order but not the truth cognition is in the foreground.

Thus, the majority of pedagogic research (especially in distance learning) is aimed at meeting the social requirements of the society. Pedagogic, as well as other branches of science, is not looking for the truth

(that is, is not fulfilling its main goal), but is satisfied with its minor role of the servant of business and democracy which are leading the country to abyss. Here we would like to put forward the following hypothesis: **the goal and idea of pedagogic in Ukraine are unclaimed** /2/.

**Changes in the science state.** The modern science changes its states, which is a natural phenomenon described in Kuhn's theory of scientific revolutions /6/. The discovery of "God's particle" or Bose particle which is the cornerstone of the Standard model that describes the Universe structure better than any other physical theory is the year's scientific sensation /7/. However, the majority of the researchers consider the Standard model as a stage on the way to another, more complicated theory which will be able to explain such phenomena as the dark substance and the dark energy. There is the reason for this.

The so called "visible" (or visual) substance which consists of the common substance and is observed by physical devices appears to make up approximately 1 % of all physical substance of the Universe. It completely covers the famous periodic table. Other 3 % is the common substance which consists of atoms or known elementary particles which are not registered by any device. This invisible substance (or "hidden mass") can be found only by the gravitation influence it makes on the "visible", registered substance. Thus, the common substance or baryon substance makes up only 4 % of the substance of the Universe. The so called dark substance (24-25%) and dark energy or cosmological vacuum (71-72%) cover the rest 96%, see fig.1. The nature of this invisible substance is not quite clear. The dark substance is thought to consist of very massive and weakly interacting particles. But as far as the particles are not discovered, the question of the substance nature is open. Bose particle was discovered in summer 2012. Dr. Tara Shears from the University of Liverpool says: "We will watch how often it dissociates into photons, Z- bosons and W- bosons. It can fit into the Standard model. If there are deviations, it means that some new physics is working. And for the first we will be able to spy upon what is beyond our current understanding time" /7/.

Bose particle is the final missing element of the modern theory of the elementary particles, the so called Standard model, that unites all types of impacts (except for the gravitation one) – strong (which cause quarks in protons and neutrons), weak (the interaction between electrons and neutrino), and electromagnetic /8/. If it is true, the scientist says it will be the revolution in physics. The theory of existence of additional space dimensions will be proved, for example. She adds that it is the most significant discovery for the last 30-40 years /8/.

The multidimensional model of consciousness, which is very important for awareness of the material in pedagogic activity, for building, prognostication, and control of the process, was reported by the author of the paper at the international conference in Moscow /9/. The model was accepted and caused no serious objections. The paper anticipates the introduction of the multidimensional model of consciousness into the pedagogic theory and further on into practice. However, there are some orthodox HAC journals which oppose the publication. A number of pedagogic magazines able to discuss modern models and problems of pedagogic gained from it. They “just” added the following statement to the cover: “The publication authors are responsible for the trustworthiness of the publications, and the opinion of the editorial board may not coincide with the published material.” This is the unbelievable breakthrough for the HAC journals, it is a revolution. Pedagogic itself (at least in Ukraine) might start coming out of the crisis since this moment. The paper is the feasible contribution of the author into the matter.

The major share of the substance in the Universe belongs to invisible components- the dark substance (the term is quite relative as far as the adequate name has not been accepted yet) and the dark matter, so the interest to the unknown substance which is invisible for an eye and any physical device is appropriate. M. Kaku, the author of the “Physics of the Impossible” and “Physics of the Future” has interviewed 300 Nobel Prize winners to write his book. He says: “As far as the dark energy is concerned, it is still one of the greatest unfinished chapters of the modern science” /10/. Can it be the invisible substance the most ancient cosmologists revived by Theosophy, Living Ethics and Teachings of The were speaking about? Does the substance form the invisible world (or at least its part) the recognition of which is still the stumbling block in the modern science? Physics has come close to the invisible world and stopped in front of it not daring to make the last step /11/. But the step had been already made by the traditional science (Bose particle), so it is time we did the second one, that is to recognize the metascientific knowledge (and metapedagogic resulting from it) and introduce it into the scientific operation. It is not an easy thing. L.M. Gindilis, the researcher of the process, says /12/: “Mounting up the stony science slope a researcher can reach the crest of the mountain range and come into the zone of the metascientific knowledge. Going along the narrow mountain range he can deviate right and again find himself at the slope of the science. He can deviate left and fall into the abyss of pseudoscience. He has to move on the razor’s edge between Scylla of the orthodox science and Charybdis of the pseudoscience.”



**New methodology.** On the issue of the consciousness which is so important for pedagogic as new material is to be understood or realized. Classical physics says that the features of the measured object visible during the measurements exist up to the measurement. The measurement itself only eliminates our ignorance in the field. Quantum physics says that features discovered during the measurement may not exist before the measurement...The reality is created, but not only realized to a certain extent /13/. M. Kaku supports the idea /11/: “The idea of the space consciousness which pierces through the Universe is, no doubt, a metascientific one. Physics comes close to the idea, and that is the most important thing.” The author of the paper built a bridge between the metascience and the classical one /9/. There remains only to discover these new types of substance which correspond to each of the 11 dimensions and find the formulae (mathematical dependencies among them and the classical substance, notably, the small part known to the modern science). When the science about the living being tests itself by the exact science, there are a lot of mishaps. Thus, Prof. Oleg Ananyin, the Head of the Centre of Methodological, Historic and Economic Research of the Institute of Economics of the Russian Academy of Science made a presentation “Economic Modeling: between the Object and the Customer” in which he mentioned the following fact: the method of evaluation of the possibility of life existence on Mars was applied to launch American satellites to Mars. The results obtained were negative. The scientists apply the method to evaluate the possibility of life existence on the Earth. It appeared there was no life on the earth, according to the methodology. No comments. So there is the reason to perfect ourselves and to have a certain attitude to the results of the official science. It requires the restrained and controllable development. It is to be done, as the knowledge your war rival has (the information war has never stopped) is always used in any case. New thoughts (the traditional science has been always fed by them in science fiction, for example) should be taken as hypothesis even in this situation. All modern inventions did it.

**The criteria of the ultra-scientific knowledge.**

The requirements to the Source of the Ultra-scientific knowledge are given in /12/:

5. Its trustworthiness (authenticity) is to be unquestionable.
6. As far as it is an original document which refers to a certain epoch, it is to be reflected in the language of the Source: the terms are to correspond to the “scientific” language of the epoch it refers to. It is absurd to expect the application of modern

differential equations in the source which refers to the epoch of Ancient Egypt.

7. The next question is as follows: How far can the Source outstrip its epoch? If it looks into the very far future it may pass by the consciousness of its contemporaries. For this not to happen the authors of the document are to keep to the knowledge understandable for that period of time.
8. Finally, for us to use the criterion of the ultra-scientific knowledge we are to know the epoch of the Source and the state of the science of the time very well, to be aware of what is understandable for it and what is beyond its knowledge. //

The idea of existence and value of the least linear measure in the ancient Indian science can be an example of the knowledge which is beyond its epoch. There are some examples concerning Stonehenge in /15/. The detailed analysis of modern sources of metaknowledge (Theosophy, Agni Yoga, Teaching of The) made by Gindilis /12/ is an important addition to it. It is a collection of more than 50 papers of one author on the topic. We can find more information in the proceedings of the conference “Ethics and the Science of the Future.” Thus, L.M. Gindilis, the astrophysicist, full member of the K.E. Ciolkowski’s Russian Academy of Cosmonautics, Honoured worker of M.V. Lomonosov’s MSU examines the concept of the Sun in the sources and in modern physics. They completely correspond to the above mentioned criteria. The Source says that  $1/3$  of the energy is obtained by the Earth from the Sun, and the rest  $2/3$  – from meteorites. The calculations made by L.M. Gindilis prove this odd at first glance assumption. Thus, the criteria can be used in the ultra-scientific knowledge- in metapedagogic. The mankind has got the Knowledge with its help during all known (and unknown) centuries. This fact is also discussed in energy and information pedagogic /16/. The evolution pedagogic also speaks about it.

The author of the paper /17/, which is interesting even due to its title (The Materiality of the Consciousness), says: “The energy of the consciousness makes modern statesmen, politicians and businessmen drive to the inevitable conclusion on the social significance of work aimed at raising the level of consciousness and culture of all workers without any exception. The raise of the level of consciousness and culture is the most powerful stimulant of energy for millions of people. Nowadays, when global information is becoming the productive power, its energy is the force which only the person able to use its might in full capacity can resist”. The author of /18/ says: “The book helped to focus our attention and pushed forward the deeper and more creative thinking. The Internet,

on the contrary, encourages us to use quick unrelated pieces of information from many sources. It is the ethics of the industrial epoch, the ethics of speed and efficiency, the optimized productivity and consuming. The Network is reforming us according to its image and likeness. We are the followers of the quick and superficial scanning and are losing the ability to concentrate ourselves, think and reflex”. The paper itself is written in this very manner because of the requirement of the epoch which is to have time to say something very important as according to /19/ the mankind has been falling into the abyss and passed the turn when there had been a chance to slow down and follow the road bend. But it has no time to break, either ...

**Conclusions:** So, we are coming close to the concept of **synthetic pedagogic** which consists of:

- **Evolution pedagogic.**
- **Energy and information pedagogic.**
- **Metapedagogic.**

The hypothesis of generalization of pedagogic (it is called synthetic pedagogic) which consists of evolution pedagogic, energy and information pedagogic and metapedagogic is given in the paper. Metapedagogic is waiting for the researchers and is unattainable so far (only pedagogic geniuses could attain it). Energy and information pedagogic is described quite well and it is to be further developed which is shown in a number of papers. The character of the evolution pedagogic is also discussed as the purpose function of the mankind (country, organization, and family) is yet to be found out. Ukraine, for example is looking for its national idea. The author said about it in /20/. Though only the Institute of Strategic Research is able to solve this task. To conclude we would like to cite the quotation obtained by the metapedagogic method (all papers of the famous on the Earth geniuses used it). It belongs to the Teacher Koot Hoomi: “Exact science is based on the experience and has nothing in common with the moral, virtue, and philanthropy. Thus, it cannot claim to our help until it is in harmony with metaphysics. It is only a cold classification of facts which are external to a person...The exact science does not care about the results obtained by its methods and the consequences for the mankind. Therefore, if our sphere is as far beyond the sphere of the exact science as the orbit of Uranus from the Earth is, we refuse to be broken on the wheel of your science...”

## References:

1. S.U. Goncharenko. Pedagogic Research: Methodological Recommendations to Young Researchers. – Kiev-Vinnitsa: DOV Vinnitsa, 2008, - 278 p.
2. S.G. Dzhura. Philosophical Approach to the Analysis of Modern Pedagogic (applied to Ukraine). [http://ea.donntu.edu.ua:8080/jspui/bitstream/123456789/14525/1/pedagog\\_filos.doc](http://ea.donntu.edu.ua:8080/jspui/bitstream/123456789/14525/1/pedagog_filos.doc)
3. P.F. Belikov. Roerich. Spiritual Biography Experience. – N.: ICP “Lazarev and O” 1994. – 201 p. <http://www.roerich.com/zip/belikov.zip>
4. Sides of Agni Yoga. 1955. – N.: Algim, 2001. – 704 p. [http://www.roerich.com/zip3/grani\\_55.zip](http://www.roerich.com/zip3/grani_55.zip)
5. L.M. Gindilis. Consciousness and its Role in the Universe: Scientific, Philosophical and Metascientific Aspects // Proceedings of the X interdisciplinary scientific conference “Ethic and the Future Science” – Consciousness as the Space Making Force – M.: Delphis, 2011. - p. 5-13.
6. Kuhn T.S. The Structure of Scientific Revolutions. Chicago, 1962; M., 1975. –<http://www.psylib.ukrweb.net/books/kunts01/index.htm>
7. Scientists Declare Higgs Boson Discovery. – BBC Ukraine, [http://www.bbc.co.uk/ukrainian/ukraine\\_in\\_russian/2012/07/120704\\_ru\\_s\\_higgs\\_boson\\_discovery.shtml](http://www.bbc.co.uk/ukrainian/ukraine_in_russian/2012/07/120704_ru_s_higgs_boson_discovery.shtml)
8. God’s Particle Exists: Physicists Declared Higgs Boson Discovery: <http://techno.bigmir.net/discovery/1521536-Chastica-boga-suchshetvuet--fiziki-oficial-no-ob-javili-ob-otkrytii-bozona-Higgsa>
9. S.G. Dzhura. To the Problem of Multidimensional Consciousness// Proceedings of the X interdisciplinary scientific conference “Ethic and the Future Science” – Consciousness as the Space Making Force – M.: Delphis, 2011. - p. 30-39.
10. M. Kaku. Physics of the Impossible. – M.: Non-Fiction, 2010. – 457 p.
11. M. Kaku. Physics of the Future. – M.: Non-Fiction, 2012, - 584 p.
12. L.M. Gindilis. Scientific and Metascientific Knowledge. – M.: Delphis, 2012. – 576 p.

13. B.N. Menski. Consciousness Concept in the Context of Quantum Mechanics // Progress of Physical Science, 2005. Volume 175, №4. – p. 413-435.
14. J. Nehru. Discovery of India. – M.: Foreign Literature Publishing House, 1955. – 434 p.
15. A.A. Grobovski. Ancient History Mysteries. – M.: Znanie, 1971. – 534 p.
16. I.P. Podlasi. Energy and Information Pedagogic. - M.: Data Square , 2010. – 424 p. <http://www.roerich.com/zip3/energoenergy.zip>
17. A. I. Yakovlev. Consciousness Material Nature. – M.: Infra- M, 2011. – 261 p. (Scientific Thought).
18. N. Karr. What the Internet Does with our Brain. – M.: BestBusinessBooks, 2012. – 256 p.
19. A.P. Nikonov. Riding on a Bomb. – M.: Upgrade, 2008. - 152 p.
20. S.G. Dzhura. Ukrainian Idea as a Component of the Russian Idea in the Context of the Universal Values // Proceedings of the VIII interdisciplinary conference “Ethic and the Future Science: Russian Idea in the Context of the Universal Values” Moscow: Delphis, 2008. – p. 78-84. <http://ethics.roerich.com/doc/kultura/ukrain.htm>
21. E. Blavatskaya. Do you Really Think you Know me?” Collection of articles edited by O. Kracheva, G. Zaidman, N. Ivashchenko, L. Dmitrieva. – Kiev: Publishing House Ivashchenko, 2012. – 496 p.

#### **4.8. Application of neural networks to improve distance education of power engineering students**

S.G. Dzhura

*Opportunities to use neural networks to create distance learning open tests for power engineering students are shown. Experimental research to introduce the tests into a course is described.*

**Problem general statement; Link with scientific and practical knowledge.** The distance learning has been widely spread recently. It is

becoming more popular as it gives the opportunity of getting education to all population categories – from disabled people to the specialists that desire to get another degree. Besides, the distance learning helps solve many tasks stated by the country, namely to widen the opportunities of inclusive education and personnel retraining, etc.

However, the distance learning has a number of problems that need to be solved. Insufficient direct contact of a teacher and students is the most important one in the aspect of the researched problem. The current distance learning systems are short of tests similar to the traditional exam where the teacher marks the tests. The current tests look like a lottery which always has a correct answer and there is a chance to guess it. Open tests do not have the shortcoming. They correspond to a special series of 3-5 open questions (those that allow the student the answer free forming) covering the topic. They are more often used in cases where the student is to demonstrate the contents understanding (the second and further learning levels). The open question answer evaluation criteria are to be given, for example:

Minimum three complete sentences are to be in the answer.

The representation is to be modern.

The answer is to be complete.

The answer is to be accompanied by minimum one example.

**Application of tests in the distance learning:**

It is the testing system which is most developed in the distance learning technologies. The Ukrainian education is lacking behind as to the test development and application and the distance learning itself. The testing as the academic progress assessment from is not ideal. However it is the only possible way to assess knowledge with the help of computer.

There are a lot of tests at present. They can be divided into some groups.

The first group – multiple choice tests and their varieties:

Identification tests are the tasks which need the alternative answer: “agree”, “disagree”, “yes”, “no” etc.

Differentiation tests have the answer versions out of which one or some should be chosen.

Correlation tests propose finding common or different features in the objects correlating them according to the characteristics, parameters, classes etc.

Tests-problems give the problem situation, necessary data and answer versions in the form of digits and letters. The student is to choose the correct answer. The problem can also be formulated in such a way for the student to choose the correct sequence of actions, operations or define the factor dependence.

The test tasks can be represented in different forms – graphic, verbal, table, symbolic etc.

The tests are made to assess knowledge-ideas and understanding of the material (that is they correspond to the I level of learning). They are suitable for the current testing and self-assessment.

The second test group does not have standards (the answer options).

They are used to assess the material understanding and some skills that is they correspond to the II and III (partially) learning levels.

Varieties:

Test-substitutions: The tasks have different forms and have some omitted elements – words, components, schemes, graphs etc. The student is to fill in the gaps.

Structural tests do not have tips and answer options. They require the student to give the answer: to write a formula, to form characteristics, to build the operation succession, to do a scheme etc. The tests are also divided into two parts:

Tests-problems do not have answer options. The answer itself is definite that is there is a standard and the assessment depends on the correspondence to the standard.

Test-processes assess the ability of the students to develop different processes and their succession.

The new generation tests can be made up with the help of artificial intelligence aimed at solving tasks that man can solve and the computer can not. Our task is to let the computer solve it well.

**The investigation goal is** to develop neural network system that controls the open question assessment.

**The investigation tasks** are as follows:

1. To analyze the current programs aimed at the problem task solving.
2. To choose and reason the application of the neural method necessary for the distance learning.
3. To develop the neural network algorithms for the open questions.
4. To introduce the found mechanism to the current system of the distance learning to teach power engineering students.

**Neural networks (NN) advantages** The neural networks can generalize the obtained knowledge (teaching on the examples) and transform it into new one that was not found in the subject matter area /1/. The NN is steady and does not depend on the mood and thus is objective. The NN can extract and use the knowledge that is unknown to those who teach it and can bypass its founder /2/. The NN allows understanding the answer (or question) subtext.

**The NN tools review /3/**

**The free resources are as follows:**

1. Basis-of-AI-backprop.
2. FuzzyCOPE.
3. Mactivation.
4. NeurDS.
5. NeuroSolutions.
6. PDP
7. Rochester Connectionist Simulator
8. SNNS.
9. The Brain.
10. Xerion.

**The paid ones::**

1. BrainMaker
2. BrainMaker Professional 5.1
3. Genetic Training Option (GTO) for Brain Maker Professional
4. MATLAB Neural Network Toolbox 3.0
5. NeuroShell2/NeuroWindows
6. NeuralWorks Professional II Plus (from NeuralWare)
7. NnetLib 'C'.
8. Propagator.



**The interim conclusions.** To achieve the investigation goal the paid package NeuroSolutions, its methodology and tools is more suitable to be used /4/.

**Analysis of the latest research and publications; Unsolved problems.** The subject-matter of the distance learning with the application of artificial intelligence is researched by many famous scientists with E. Polat, E. Rybalko, P. Stefanenko, L. Tovazhnyanski, A. Khutorskoi, V. Chursinov being among them. The neural networks are not applied in full. Pedagogues are interested in open questions application and machine teaching process. The issue is not fully studied in educational practice.

**The paper goal is** to describe the application of the neural networks in pedagogic process and give the results of the research on their introducing into the power engineering students teaching.

**Short introduction into the neural networks.** The neural networks are sorted out of the artificial intelligence and described in the fundamental works ( doctoral dissertations that used more than 1000 references on the subject matter /5,6,7/).

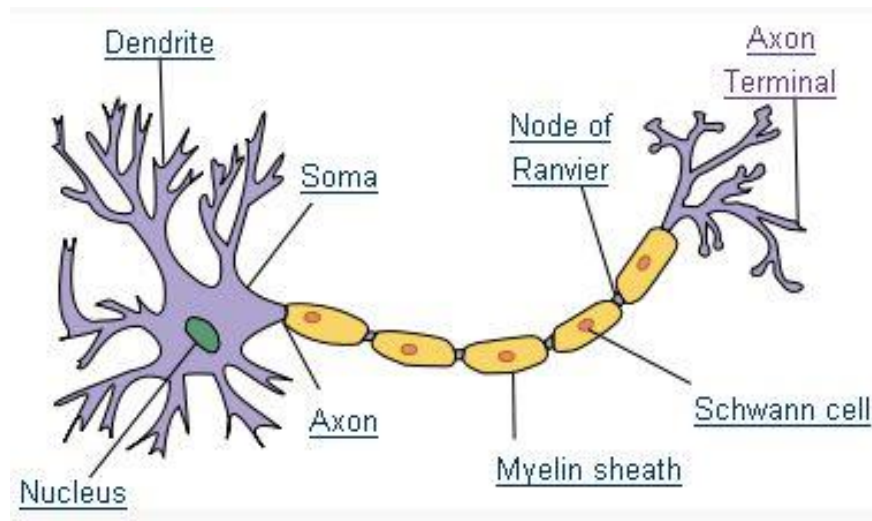

Fig. 1. Parts of a neuron.

The neural networks model human thinking. The human brain biological neuron is shown in the fig. 1.

Every neuron consists of the cell body (or soma) that has the cell nucleus. Many short fibers that are called dendrites and one long called axon branch off the cell body. The axon stretches for a long distance which is much longer than it is shown in the figure. As a rule the length of the

axon is 1cm (which is 100 times as much as the cell body diameter) but it can also reach 1 m. The neuron makes up combinations with other neurons the number of which can be from 10 to 100 000 in the junction points called synapses. Signals are spread from one neuron to another with the help of a complex electrical and chemical reaction. The signals control the brain activity within a short period and cause long time changes in the state of the neurons and their combinations. The mechanisms are considered to be the basis for learning. The information is processed in the cerebral cortex which is the outer layer of the brain neurons. The tissue bar with the diameter of about 0.5 mm stretches along the cortex depth the thickness of which makes up about 4 mm is the main structural unit. Every bar has about 20 000 neurons /5/.

According to the research in neurology the joint work of simple cells can cause thinking, action, or consciousness which means that the brain gives birth to intelligence /6/. The only alternative to the theory is mysticism that states that there is some mystic space beyond physical experience in which the intelligence functions.

The brain and computer have absolutely different characteristics and fulfill different tasks. Fig. 1 shows that the typical human brain has 1000 times as much neurons than logic elements in the high class typical computer processor. According to Moore's law (the transistor density calculating on the square unit is doubled every 1 -1.5 years) the number of the logic elements in the processor will have been equal to that of the neurons in the brain by 2020. It does not mean much and the difference in the number of elements is insignificant compared with the difference in the speed of switching and paralleling degree. The computer micro schemes obey a command in a nanosecond while the neurons act million times slower. However, the brain makes up the shortcoming as all its neurons and synapses act simultaneously while the majority of the modern computers have only one processor and not many of them. Thus despite the advantages of the computer in the switch physical speed the brain fulfills its actions 100 000 times quicker. The situation is being changed in favour of the computer. Whether it is good or bad the time will show. All famous researchers (S. Khaikin for example) study the case /7/. There is no solution as everything depends on the human joint one.

The scheme of the formal neuron is shown in the fig. 2.

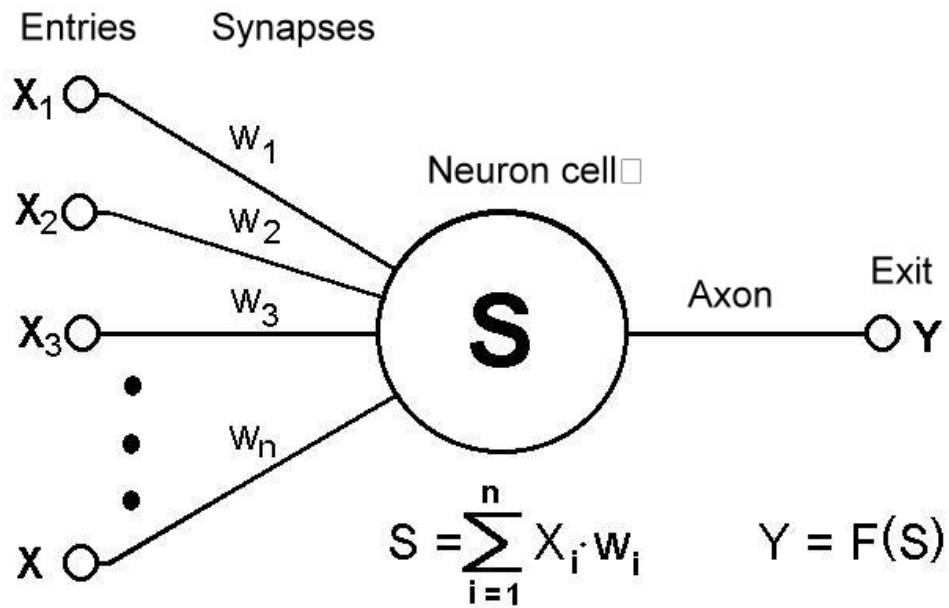

Fig. 2. The formal neuron scheme.

Parameters  $x_i$  in the formal neuron model sense organs (sight, sense of smell and touch etc). Each impact parameter is multiplied by the weight coefficient  $w_i$ , that is any parameter is important to solve a task. In the summator the process is implemented through the threshold function. For example, somebody pushed a man slightly in the transport (it is lower than the threshold functioning). In this case the man does not show any reaction. But if the push is hard the reaction exceeds the threshold level and the summator calculates the final impact.

Table1. Comparison of physical calculating resources in the computer and the brain (the computer indices are growing, the brain one are unchanged within the last 10000 years).

	computer	human brain
Computation modules	One central processor, $10^8$ logic elements	$10^{11}$ neurons
Memory modules	Main memory of $10^{10}$ bits	$10^{11}$ neurons
	Disk of $10^{11}$ bits size	$10^{14}$ synapses
Processing cycle time	$10^{-9}$ seconds	$10^{-3}$ seconds
	$10^{10}$ bit/sec	$10^{14}$ bit/sec

Capacity		
The number of memory updates in a second	$10^9$	$10^{14}$

The main rule in the neural networks is that they are not programmed but taught, like people. When we study the neural networks, we study cognitive science the scheme of which is given in the fig. 3.

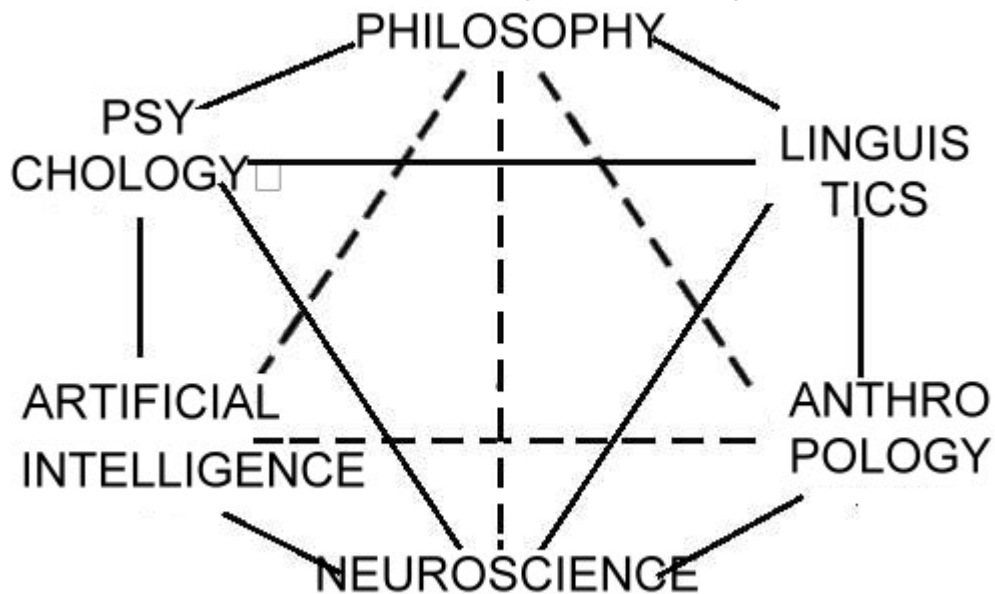

Fig. 3. Cognitive science interdisciplinary links

According to H. Gardner the main elements of cognitive science are as follows (Gardner, 1987):

- consciousness philosophy;
- neural science;
- cognitive anthropology;
- linguistics;
- computer science and artificial intelligence (the latter is an interdisciplinary field in the combination with psychology and linguistics as minimum).

**What the neural networks can do and what pedagogic problems can be solved /8/:**

- Image recognition (can be used to define the personality psychological type according to Szondi method and the method to be used in a particular case).
  - Psycho diagnostics (works of M. Dorrer in development of psychological intuition in neural network expert systems) /9/. The results discover the mechanism of the neural network intuition appeared while they solve psycho diagnostics problems. The non-typical intuition approach in psycho diagnostics was created which excludes the described reality building. It shortens and simplifies the work at psycho diagnostics methods development.
  - classification and clusterization ( division of the data according to examples; tests that divide students into the kinaesthetics, audials, visuals and picking out of the method for the distance learning course).
    - Decision making and control. The task is similar to classification that deals with situations the characteristics of which are sent to the neural network login. The sign of the solution the network made appears on its logout. Different criteria of description of the controlled system state are used as input signals.
    - Forecasting or approximation ( there are parameters of student testing that can not be represented as a formula; in this case the neural network that can forecast on the basis of training examples can solve the task).
    - Data compression or associative memory is the ability of the neural networks to find interrelations among different parameters that allows expressing big size data in a compact way if the data is closely connected. The reverse process is r
- Fig.4. Starting menu of the package NeuroSolutions ver.6.0



econstruction of the initial set of data from information. It is called the (auto) associative memory. The associative memory renews the initial signal/image from noisy/ broken input data. Solving of the task of geteroassociative memory allows implementing the memory which is addressed according to the contents.

#### **Task solving stages /10/:**

- Collection of the data for learning;
- Data preparation and normalizing;
- Choice of the network topology;
- Experimental choice of the network characteristics;
- Experimental choice of the learning parameters;
- Learning;
- Learning adequacy checking;
- Parameter correction and the final learning;
- The network verbalizing /11/ and its further operation.

**Appliocation of the neural networks in pedagogic.** We worked in different packages, but NeuroSolutions ver.6.0 appeared the most visual. It allows working with the Exel tables and integrates into it for forecasting,

for example, of financial risks. In pedagogic it might be indices of the academic process quality according to the previous onservastion or other pedagogic parameters. The certain network can be chosen for training tasks ( fig.5.)

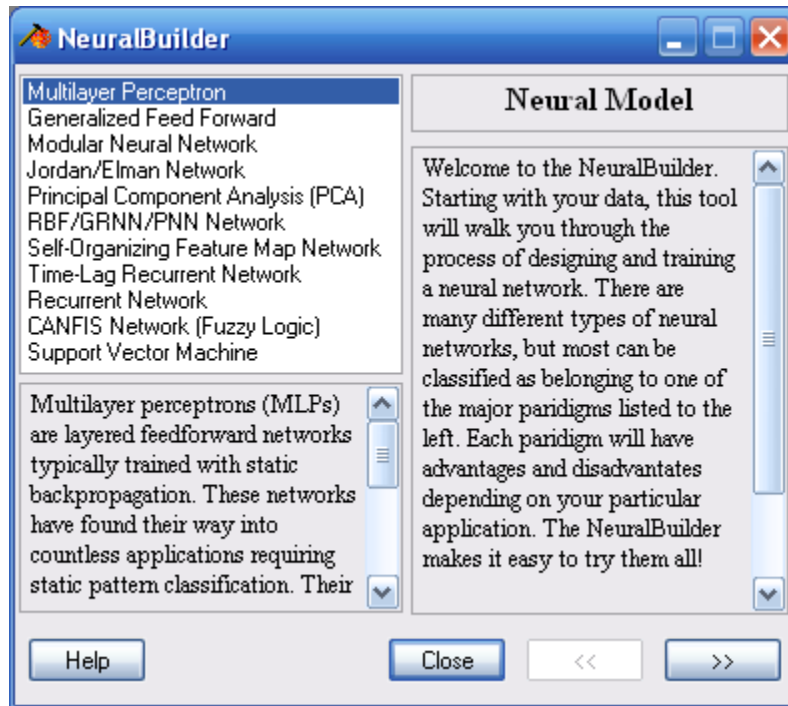

Fig. 5. Choice of the neural work for an advanced user network can be chosen to solve a learning task (see fig.5).

NeuralBuilder is the external programmes that helps a user design and install the neural network. It builds any of the 11 the most popular neural networks which a described below:

1. Multilayer perceptions (MLPs) are laminated networks of direct distribution that are trained with the static feedback. They are used to solve the tasks that require the pattern static classification. They are suitable and can approximate any input/product card. The key disadvantages are that they are trained slowly and require much training data (three times as much of the training patterns than the network weight).

2. The generalized network of direct distribution generalizes the MPL in such a way that links can jump over one or more layers. The MPL can give the theoretical solution of any problem that the direct distribution generalized network can solve. In practice the networks can solve the problem more efficiently. The classical example of it is two spiral problems. Suffice it to say that the standard MPL requires hundred times as

much training epochs than the direct distribution generalized network containing the same number of element processing.

3. The direct distribution module networks (NDD) is the special class of the MPL. They process their input using some parallel MPLs and then combine the results iteratively. It has a tendency of creation of a structure within topology to specialize a function in every sub module. Unlike the MPL, the module networks do not have interrelation among the layers. That is why a less number of weights are required for the same size network (that is the same number of PEs). It fastens the training time and reduces the number of patterns necessary for the training. There are many ways to segment the MPL into the modules. It is not clear which is the best way to design the module topology based on the data. There are no guarantees that every module specializes its training on the unique data part.

4. Jordan's and Elman's networks widen the laminated perception with the context units which process the elements (PEs) that remember the past links. The context units give the network the ability to extract the temporal information out of the data. The activity of the first hidden PEs in the Elman's network is copied to the context units while the Jordan's network copies the network product. The networks that feed the input and the last hidden layer to the context units are also accessible.

5. The main components of the analytical network (PCAs) combine learning with a teacher and without him in the same topology. The main constituent analysis is a linear procedure of training without the teacher which has a number of uncorrelated characteristics and main components from the input. The MPL is controlled to do a non-linear classification of the components.

6. The radial basic function of the network (RBF) is non-linear hybrid networks that contain, as a rule, the only hidden layer of the element processing (PEs). The layer uses the transfer Gaussian functions but not the standard of the sigma function used by the MPLs. These tendencies learn faster than the MPLs. If the generalized regress (GRNN)/probability network (PNN) is chosen, all the weights of the network can be calculated analytically. In this case the number of the group centers equals to the number of the patterns and they are put in the same difference. The type of the RBF is the best one when the pattern number is small (<1000).



7. The self-organising networks (SOFMs) transform the input of arbitrary measurement in one or two discrete dimension cards subjected to topological restriction. The cards are calculated with the help of the Kohonen network. The main advantages of the network are a cluster analysis and a classification.

8. The temporary isolated recurrent networks (TLRNs) are the MPLs with the widened structures of the short-term memory. The majority of the real world data has the information on the time structure that is the data is changed in time. However the majority of the neural networks are just static classifiers. This type of the network is recommended under the time dependencies.

9. The recurrent networks return the hidden layer to themselves. The current networks are started with the fully current network and add the direct connection network that bypasses retraining (it is not good) and examines the current part as the main memory. The current networks can have the memory endless depth and find the relations within the time as through the instant input space.

10. The fuzzy logic model (The CANFIS - Co-Active Neuro-Fuzzy Inference System) combines the conformable fuzzy inputs with the module neural network and the fast and approximate complex functions. The input fuzzy systems are valuable as they combine the rule explanatory nature (membership functions) with the force of the neural networks of the “black box”.

11. The Support Vector Machine (SVM) is implemented under the adaptation algorithm nucleus. The card unit inputs of the network are adapted to the data multidimensional space and divide the data into the corresponding classes and isolate the inputs close to the data boundaries. That is why the nucleus of the networks is especially efficient when the data units that separate complex boundaries are detached. The network type can be used only for the classification, not for the function approximation.

How is the network built in the package?

NeuroSolutions supports the so-called local total model in which any component can activate and study the usage of its own weight and activation and that of the neighbours. It is an analogue to modeling as every component of the neural network is a separate object that sends and gets

messages. The user's graphic interface (GUI) with the based construction of the network symbol takes it into account in its turn.

Let us discuss the work of the neural network on the example. We have the following students' parameters in our research: age, average marks got during exams, the personality psychological type, birth place, a social status. The data is in the format of Exel, csv, txt and the network studies and forecasts on its basis.

Fig. 6 shows the visualization of the neural network which can be taught, change parameters of any axon and network type etc. The task is to choose the best network for every necessary task. There is little theoretical data; there are general recommendations described above. Thus, the network for creation of the open texts is to be taught on a big number of patterns. The more patterns we have, the better. However, the results should be checked (a new pattern which was not in the training sample is to be given and the answer is to be checked). Fig. 7 shows the package final report made up after the work stages. The achieved results can be evaluated according to the given statistic parameters.

Fig. 6. Visualization of the neural network for the examined pattern  
There is a question whether the algorithms can be built in the current

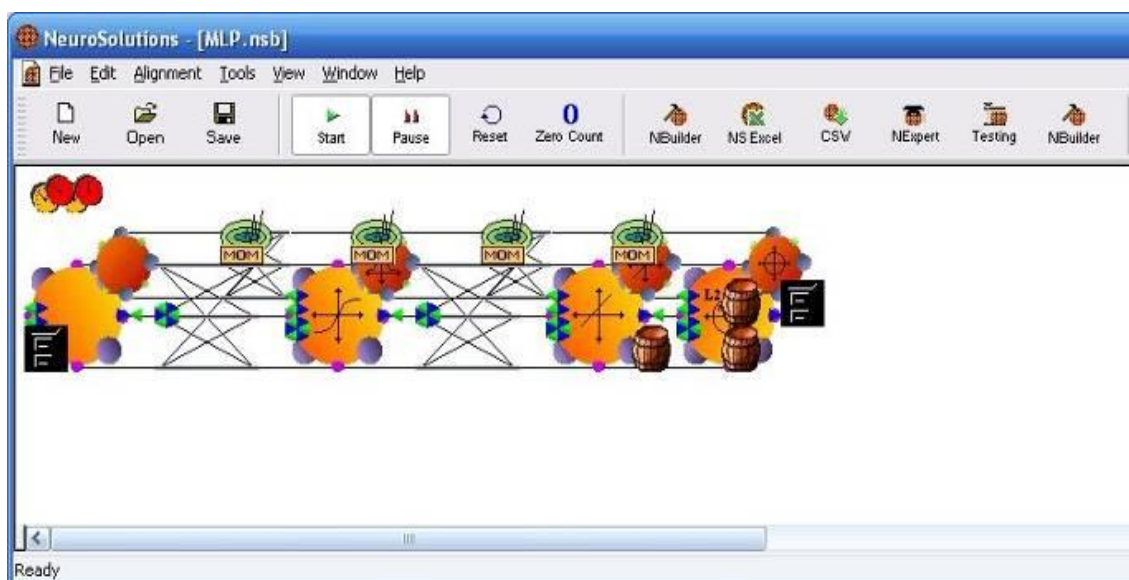

system of the distance learning. The answer is positive. NeuroSolution has a dynamic library links (DLL's) for this. Any component has a program of

Fig. 7. The general statistics and some recommendations on each works stage are given after the training and getting of the results

The screenshot shows a Microsoft Excel spreadsheet with the following data:

Output / Desired	Setosa	Versicolour	Virginica
Setosa	14	0	0
Versicolour	0	22	0
Virginica	0	1	13

Performance	Setosa	Versicolour	Virginica
MSE	0,000325135	0,013264757	0,01324138
NMSE	0,001612774	0,053400792	0,068822142
MAE	0,008745395	0,062376506	0,063540575
Min Abs Error	7,09868E-05	0,00223613	0,000114233
Max Abs Error	0,106767675	0,640742372	0,634590314
r	0,999216369	0,97367833	0,966155379
Percent Correct	100	95,65217391	100

The 'Varying Network Parameters' dialog box contains the following text:

**Test Varied Network**

In this step we will use the data set tagged performance of the best network found in t network weights were automatically saved loaded into the breadboard before the testir. "Test Network" button now to run the testir confusion matrix in the resulting testing rep yourself that the network did a good job of plants.

Test Network

default actions which can be made and edited on the computer page and then assembled with the MS Visual C ++.

**Study of the obtained results; Conclusions** The paper examines the application of the neural networks of different types in pedagogic research and creation of test open questions. The obtained practical result is to be developed. Different approaches to solve the tasks are analyzed. The weak point of the approach is the great number of training patterns to each question. However the approach makes the distance learning much closer to the traditional one.

#### References:

1. L.N. Yasnitski. Artificial Intelligence. Textbook. - M.: Binom, Knowledge Lab, 2011. – 240 p.
2. Doug Valentine. Distance Learning: Promises, Problems, and Possibilities // Online Journal of Distance Learning Administration. – Volume V. – West Georgia: State University of West Georgia, Distance Education Center, 2002. – Режим доступа: <http://www.westga.edu/~distance/ojdla/fall53/valentine53.html>

3. Review of the tools with neural networks  
<http://www.westga.edu/~distance/ojdla/fall53/valentine53.html>
4. S. Tolkachev. Neural Programming of Dialogue Systems. – StPb.: Korona-Vek, 2011.
5. S. Russell, P. Norwig. Artificial Intelligence: Modern Approach, 2<sup>nd</sup> Edition: Publishing House Williams, 2006. – 1408 p.
6. D.F. Lyuger. . Artificial Intelligence; Strategies and Methods to Solve Complex Problems, 4<sup>th</sup> edition. Translated from English. – M.: Publishing House Williams, 2005. – 864 p.
7. S. Hikin. Neural Networks. 2<sup>nd</sup> edition. Translated from English. M.: Publishing House Williams, 2006. – 1104 p..
8. Gorban A.N., Rossiyev D.A., Dorrer M.G., MultiNeuron — Neural Networks Simulator for Medical, Physiological, and Psychological Applications, Wcnn'95, Washington, D.C.: World Congress on Neural Networks 1995 International Neural Network Society Annual Meeting: Renaissance Hotel, Washington, D.C., USA, July 17-21, 1995.
9. M. Dorrer. Psychological Intuition of the Artificial Neural Networks, Dissertation, 1998. <http://psyfactor.org/lib/dorrer-0.htm>
- 10.SMS Web-Tutor // <http://www.distance-learning.ru/db/el/C6B0F929C950E425C3256C5B005C65D1/doc.html>
- 11.E. Mirkes. Logically Transparent Neural Networks and Making of Explicit Knowledge out of Data, in the book: Neuro Information Science/ A. N. Gorban, V.L. Dunin-Barkowski, A.N. Kiridin and others. – Novosibirsk: Nauka. Siberian Company RAH, 1998. – 296 p.

## 4.9. Application of the visualization gas-discharge chamber to improve distance learning system for power-engineering students

S.G. Dzhura

*Possibilities of application of the visualization gas-discharge chamber to improve distance learning system for power engineering students are analyzed in the paper. Technical characteristics and the chamber creation history are presented. The research on implementation of the visualization gas-discharge chamber in the distance learning system for power engineering students is described.*

**Key-words:** *distance learning, visualization gas-discharge chamber, visualization gas-discharge method, vibration scale.*

**The problem general statement; link with scientific and practical knowledge** The distance learning has been widely spread recently. It is becoming more popular as it gives the opportunity of getting education to all population categories – from disabled people to the specialists that desire to get another degree. Besides, the distance learning helps solve many tasks stated by the country, namely to widen the opportunities of inclusive education and personnel retraining, etc.

However, the distance learning has a number of problems that need to be solved. Insufficient direct contact of a teacher and students is the most important one in the aspect of the researched problem. The current distance learning systems are short of control made by a teacher as to the material understanding especially when the new one is stated. Whether a student understood the material is clear only after testing of a block of knowledge.

The problem can be solved by implementation of the visualization gas-discharge chamber into the distance learning process. The chamber fixes the reaction of the trainee on the studied material that allows correcting of the teacher's activity based on the obtained data.

**Latest research and publications analysis; unsolved problems** Such scientists as E. Polat, E. Rybalko, P. Stefanenko, L. Tovazhnyanski, A. Khutorskoi, V. Chursinov and others are making research in the distance

learning. The feedback issue in the distance learning has not been totally studied yet. The human radiation fixing, its application in education is also not studied yet.

**The paper goal** is to describe the application of the visualization gas-discharge chamber in the pedagogic process and to give the results of the research on its implementation into the distance learning system for power engineering students.

**The main material statement; the obtained results study** The means of supply of the information in distance learning reduce the range of transmitted frequencies to minimum. The sound frequencies in this case equal to 20 – 20000 Hz. Very high quality loudspeakers produce it. For example, many people prefer going to the live music concerts as the facilities do not cut off the frequencies. According to physics there is a vibration scale [1] along which (fig.1.) the video range goes (it also is cut off under the signal traditional transmission). That is the recipient gets cut off range of the frequencies and the video (the cut off range too) without on-line feedback.

The goal is to expand the range at the expense of the invisible range (the so called recipient aura) registered by the visualization gas-discharge (VGD) chamber. The term “aura” means biochemical and psychic radiation of the human body. The degree of the material learning is defined by the aura intensity and dynamics. The glow leaps might denote understanding (the range widening) or misunderstanding (the range reduction). The glow hopping growth might mean learning of some part of the material.

According to Roerich’s pedagogic principles a student must live with his teacher in the same premises. In this way some waves analogous to the induced currents and equal to the wave frequencies of the teacher are induced in the student. We speak not only about the material understanding but also about some principles, including ethic ones. Roerich’s wife E. Roerich wrote: “Education without bringing up gives birth to big and small criminals” [2]. The modern distance learning system can not provide it. It, like the Internet, fulfills a destructive function – gives knowledge without upbringing. This contradiction requires solving. The approaches to it which have been tested at international conferences and special scientific publications are described in a number of papers of the author [3-9].

The research hypothesis was as follows: the change of the parameters of the aura of the students as the reaction on the supplied material in the system of the distance learning shows the degree of understanding and learning of the studied material that allows the teacher correcting his activity.

This can be done with the help of the teacher and students' VGD chambers. The chambers visualize the part of the human radiation that can not be seen by an eye. In summer 2011 the participants of the XIV international congress "Science; Information; Consciousness" mentioned that the world research community uses the VGD chamber as a traditional tool of research.

**The short history and physical characteristics of the VGD chamber** In the end of the 30s of the XX century the Russian inventor S.D. Kirlian discovered an interesting phenomenon- mysterious blue glow around the objects put in the EMP. He established the laboratory in which he studied the unique phenomenon and the gas-discharge glow become known as the effect of Kirlian.

Prof. Korotkov introduced a new name for the method that takes into account main physical processes peculiar to the Kirlian effect – the method of gas-discharge visualization (VGD method). To identify the method of graphic registration the term VGD-graphy was introduced and the term of VGD-gram was introduced to describe the image itself. The name of the gas-discharge visualization reflects the method physical concept more accurately and it allows ranking it with the famous generally accepted methods.

The main source of the image forming is the gas discharge close to the research object surface. Some sides of physical process under the low-current discharge actuation and influence of the research conditions and different factors are examined.

**VGD principle** The voltage impulses from the electromagnetic field are sent between the researched object and the dielectric plate on which the object is placed. For this the reverse side of the plate is covered with the transparent electrically conductive composition. The avalanche and /or creeping gas discharge the parameters of which are defined by the object characteristics is developed in the gas medium of the object and plate contact space under the field high strength. The optic system and the

chamber of the device with the charge coupling transform the discharge glow into video signals which are recorded as signal frames (VGD-grams) or AVI files into the memory block connected with the computer processing. The processor unit is a special program complex of parameters on the basis of which some diagnostic conclusions are made [10].

Prof. Korotkov gave detailed description of the VGD chamber operation and the firmware unit in his papers [11].

The proposed system of the distance learning was tested on one of such devices.

The experiment goal is to check the dependence of the aura state on the nature of the perceived information and state the influence of artistic images on the cenesthesia and readiness to perceive a new part of complex information ( with the help of switching of the load from one hemisphere to the other).

The experiment on changes of the human aura symmetry and square under the logic and image perception of the course for power engineering students “Mathematical Methods and Models” was carried out distantly from DonNTU (Donetsk) and Eastern-Ukrainian National University named after V. Dal (Lugansk). The psychologists L. Raichenko and S. Raichenko took part in the experiment.

21 people (11 as an experimental group and 10 as a control group) participated in the experiment, 6 of them being men and 15 – women. The age of the participants was from 19 to 72. 20 subjects had a university degree and 1 was a student.

The goal of the experiment was to check the hypothesis comparing the indices of the symmetry and the square of the aura of every participant under learning the material of the distance course “Mathematical Methods and Models” and “Power Engineering Mathematical Tasks” as the criterion of the visualization of understanding of the sent information by the recipient.

The research was made with the help of Korotkov’s VGD chamber compact aimed at computer registration and analyzing of the VGD-grams of human fingers with the help of the VGD method based on the Kirlian effect.



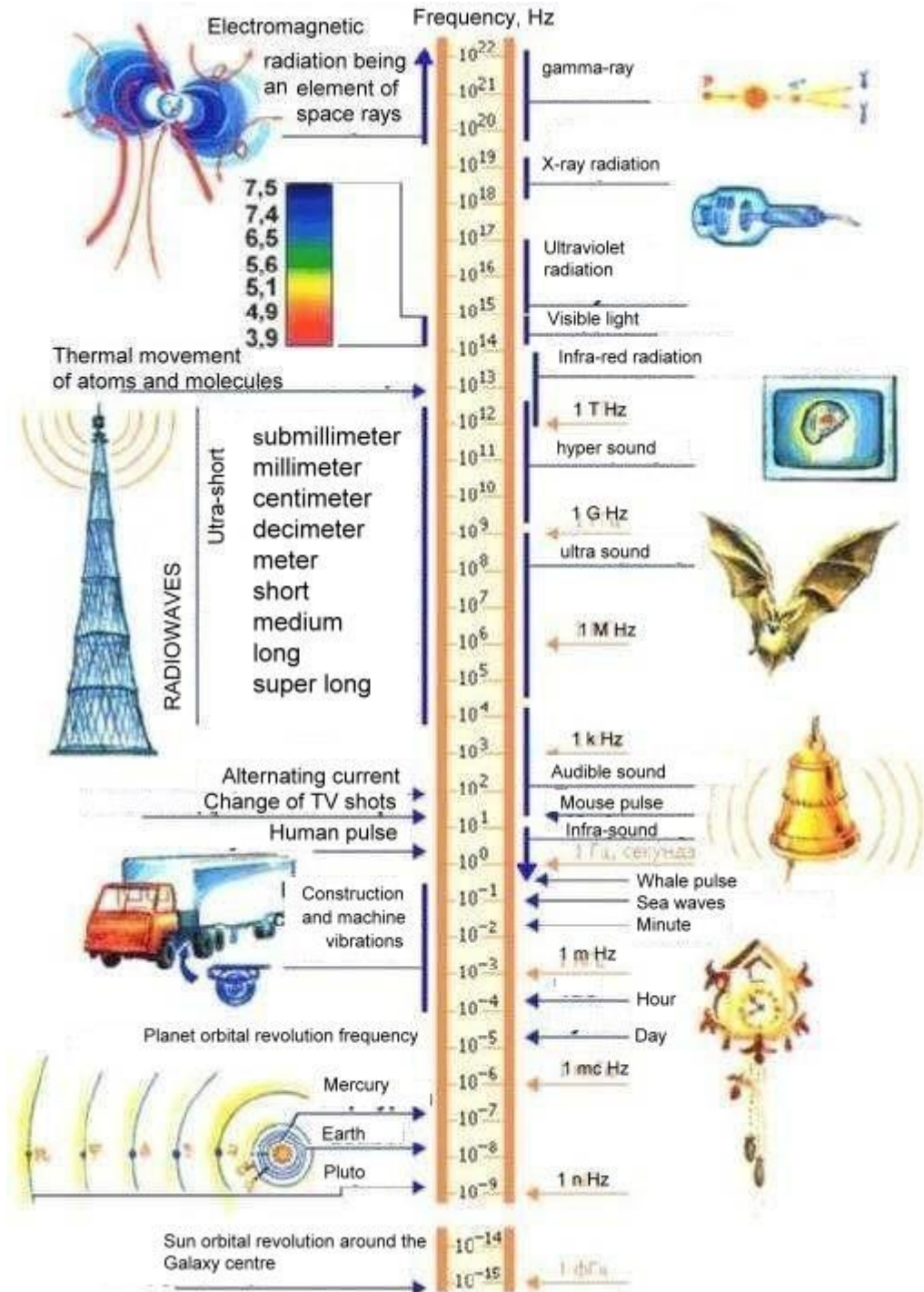

Fig. 1. Vibration scale

The measurement of the initial parameters of the aura of the subjects of the experiment was made at the ascertaining stage.

The forming experiment consisted of three stages:

1) Statement of the influence of logic thinking on the human aura by solving logic tasks of the distance course “Mathematical Methods and Models” in a stressed mode within 20 minutes.

2) To analyze the right hemisphere activity through the influence of the image thinking on the human aura the recipients looked through coloured reproductions of the paintings of Roerich within 20 minutes ( the subjects of the experiment were asked to be saturated by the colour and inner philosophy of the paintings) and had a talk on the subject-matter.

3) All participants of the experiment listened to the audio recording of the course “Power Engineering Mathematical Tasks” within 20 minutes. The interim measurements of the aura parameters of every participant were carried out after each of the stages of the forming experiment.

The final diagnostics of the participant aura state was made at the control stage of the experiment. The obtained results are shown in fig. 2, 3.

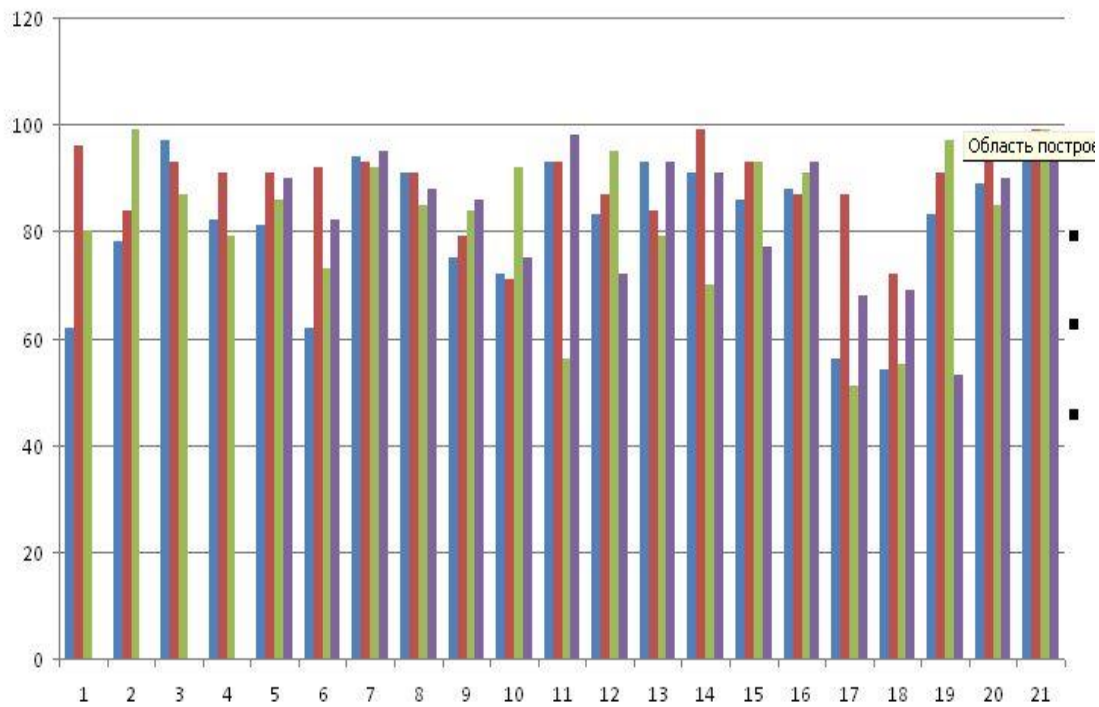

Fig. 2. Research of changes in the symmetry and square of the human aura under his logical and artistic perception of the material of the course “Mathematical Models and Methods”

Blue - the state of the aura of the subjects of the experiment at the stated stage;

Red - the state of the aura of the subjects of the experiment after the tasks of the course “Mathematical Methods and Models” were solved;

Green - the state of the aura of the subjects of the experiment after the reproductions were looked through;

Lilac - the state of the aura of the subjects of the experiment after the audio course “Power Engineering Mathematical Tasks” was listened to.

The change in the square of the aura of the research participants after understanding of some concepts is shown in the fig. 3.

Blue - the state of the aura of the subjects of the experiment at the stated stage;

Red - the state of the aura of the subjects of the experiment after the tasks of the course “Mathematical Methods and Models” were solved;

Green - the state of the aura of the subjects of the experiment after the reproductions were looked through;

Lilac - the state of the aura of the subjects of the experiment after the audio course “Power Engineering Mathematical Tasks” was listened to.

The experiment result processing showed that there was a positive dynamics in the parameters of the aura of the experimental group members (with the exception of three participants) and reduction of the aura indices of the subjects of the experiment of the control group (with the exception of two participants).

Table 1 shows the number of participants that had either increase or reduction of the aura square as a result of the work corresponding stages.

Table 1.

№	Stages	Logic (21 participants)		Image thinking (21 participants)		«Sunny Angel» (17 participants)	
		Rise	Reduction	Rise	Reduction	Rise	Reduction
1	1 - 2	11	10				
2	2 - 3			13	8		
3	3 - 4					13	4

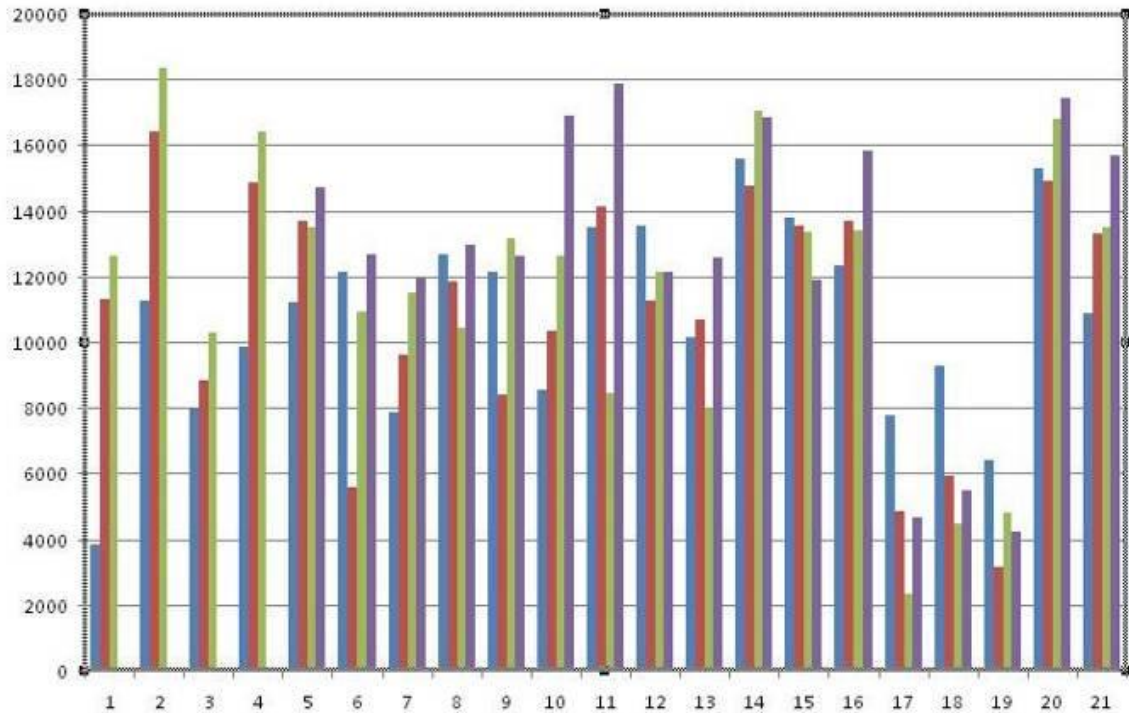

Fig. 3. Change in radiation of the participants in the process of understanding of terms

Table 2 shows the number of participants that had either rise or reduction of the aura symmetry (%) as a result of the work corresponding stages.

The experiment result analysis caused the following conclusions:

1. There was a rise of the aura square after the influence of the logic thinking in that part of the experiment subjects who was active in solving logical tasks and gave maximal correct answers (the course “Mathematical Models and Methods”).

2. The phenomenon might have taken place because the people are under heavy stress that is they *spend* too much energy to be inspired by the spiritual meaning of the painting instead of *natural accumulating* of powerful energy of the works of art and *taking it in*. Those who knew nothing about the painter and his works had sharp breakages and disharmony of the aura in comparison with the previous logical stage.

Table 2.

№	Stages	Logic (21 participants)		Image thinking (21 participants)		«Sunny Angel» (17 participants)	
		Rise	Reduction	Rise	Reduction	Rise	Reduction
1	1 - 2	13	6 (2 results without any change)				
2	2 - 3			6	13 (two results without any change)		
3	3 - 4					12	5

### Examples of the participant aura change during the research

1 stage

2 stage

3 stage

4 stage

Participant № 10



Participant № 13

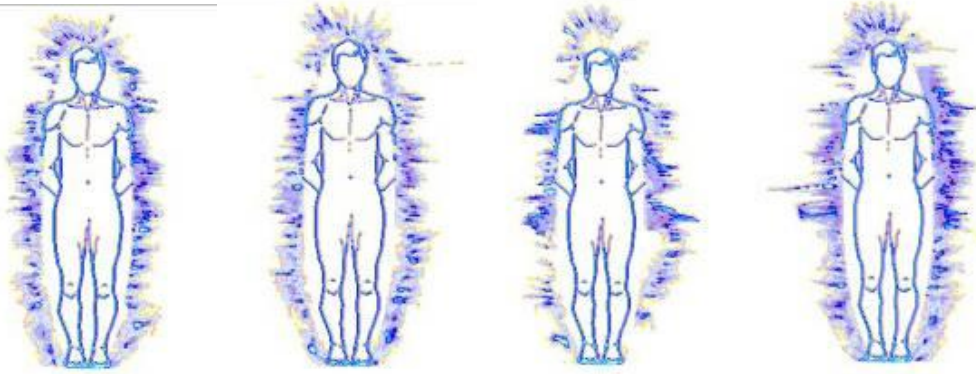

Participant № 14

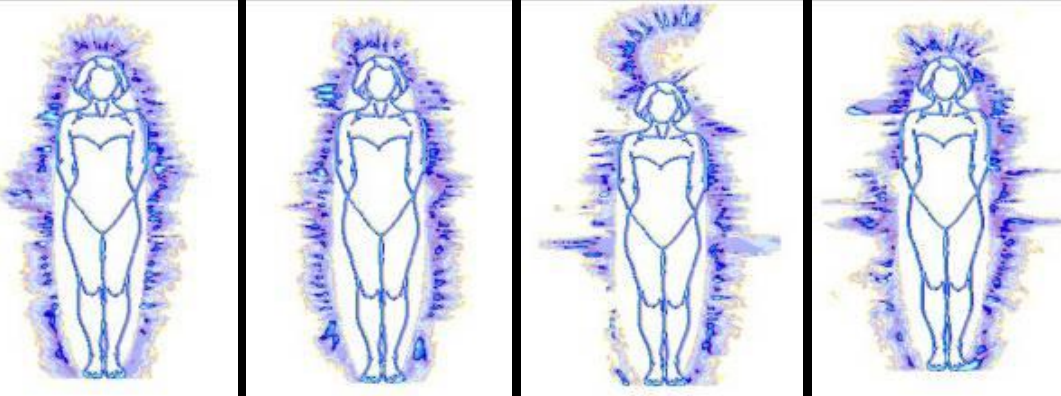

3. After the relaxation during listening to the audio recordings of the ethic and philosophical material “Sunny Angel” and the following studying of the course “Power Engineering Mathematical Tasks” (the introductory lecture) the majority of the experiment subjects had the rise of the aura square and the symmetry smoothing; practically all of them had the aura harmonizing ( the breakages were closed). It might have happened because the subjects of the experiment relaxed, *stayed alone*; they might agree or disagree with the heard things but they were not expected to give some *certain* answers and show reactions. In this case there was not any competition and they did not feel any fear of being condemned by other people. There also was a hopping change of indices when some terms were understood.

Thus the experiments made in the course of the distant learning of the material of the courses “Mathematical Methods and Models” and

“Power Engineering Mathematical Tasks” showed that the reaction of the students on the studied material can be fixed with the help of the VGD chamber. The student aura parameters are changed depending on the degree of understanding of the studied material that allows the teacher of the distance learning course to correct his activity. The analysis of the results of the fixed radiation according to the types of reaction of students and development of recommendations for the teachers as to the application of the obtained data in the pedagogic process are seen quite promising for the further research.

#### References:

1. The Vibration Physical Scale. Scientific and Philosophical Community.  
[http://nfo.agni-age.net/poster/science/Shkala\\_vibraciy.shtml](http://nfo.agni-age.net/poster/science/Shkala_vibraciy.shtml)
2. E.I. Roerich. Letters. Volume 1 (1919-1933 гг.). – M.: MCR, 1999. –[http://www.roerich.com/zip2/ei\\_1.zip](http://www.roerich.com/zip2/ei_1.zip)
3. A.V. Levshov, S.G. Dzhura, V.I. Chursinov. Outlooks of Application of the Artificial Intelligence in the Distance Education at the Modern Stage. // Proceedings of the VIII international scientific and technical conference “Mechanical Engineering at the Turn of the XXI Century”. – Volume 2. – Donetsk: DonNTU, 2011. – p. 153-157.
4. S.G. Dzhura. Pedagogic Foundations of the Application of the Artificial Intelligence in the Distance Education // Proceedings. Series: Pedagogic, Psychology and Sociology. – issue 9 (191). Donetsk: DonNTU, 2011. – p. 12-23.
5. S.G. Dzhura, V.I. Chursinov, A.A. Chursinova. Distant Learning of the Future: the Artificial Intelligence Gives New Possibilities // Engineering Education in the Development of the Modern Society: Proceedings of the International Scientific and Practical Conference. Donetsk, May 30<sup>th</sup> – June 1<sup>st</sup> 2011. – Donetsk, DonNTU, 2011. p. 174-194.
6. A. V. Levshov, S.G. Dzhura, V.I. Chursinov. Distance Learning on the Stage of Noosphere Thinking Forming // Proceedings of the IX Interdisciplinary Scientific Conference “Ethics and the

- Future Science” – Knowledge Paradigm and Education. – M.: Delphis, 2010. - p. 128-144.
7. S.G. Dzhura, V.K. Trofimyuk. The Knowledge New Paradigm // Proceedings of the IX Interdisciplinary Scientific Conference “Ethics and the Future Science” – Knowledge Paradigm and Education. – M.: Delphis, 2010. - p. 78-82.
  8. P.V. Stefanenko, S.G. Dzhura, V.I. Chursinov. Peculiarities of Application of the Artificial Intelligence in the Distance Learning // Proceedings of the VIII international scientific and technical conference “Mechanical Engineering at the Turn of the XXI Century”. – Volume 3. – Donetsk: DonNTU, 2010. – p. 122-124.
  9. Stefanenko, S.G. Dhura, V.I. Chursinov. Peculiarities of the Distance Learning at the Noospheric Development Stage. // Proceedings. Series: Pedagogic, Psychology and Sociology. – issue 7 (167). Donetsk: DonNTU, 2010. – p.33-47.
  10. K.G. Korotkov. Development of the Scientific Foundations and Practical Implementation of Biotechnical Measuring and Computing Systems of Analysis of the Gas Discharge Glow Induced by the Objects of Biological Nature. Abstract of the Ph.D Dissertation in Medical Devices and Systems/ K.G. Korotkov. – St.Pb., 1999 – 32 p.
  11. K. Korotkov: Power of our Thoughts: How our Thoughts Influence the Reality / Konstantin Korotkov. – M.: Exmo, 2009, - 352 p.; Il.- (Modern Research Library).



#### **4.10. Adaptive training system in professional training of power engineers**

**S.G. Dzhura**, Candidate of Science, Associate Professor, Director International, Donetsk National Technical University e-mail: dzhura@roerich.com

##### **Annotation**

Creation of the unique adaptive system of the distance education that provides individual approach to every student is examined in the paper. The evolution analysis based WEB applications to design the distance learning courses on the example of the application for power engineering students are presented. The partial implementation of the project in professional training of the future power engineers is described; the difficulties in its complex presentation are grounded. The author proposed the promising project of the complex adaptive training distance learning system for power engineering students with the differentiation based on the projective profound and psychological non-verbal test of L. Szondi.

**Key words:** adapting training system, distance learning, future power engineers training, WEB-applications.

**The problem general statement; Links with scientific and pedagogic knowledge.** Because of the quick renewal of the information necessary for the competitiveness of the future engineers there is a necessity in improving of the professional training of specialists in the system of higher engineering education. While the distance learning is developing there is a demand in the universal adaptive training system of the distance learning that provides the individual approach to the students. However, the system diversity and difficulties in its practical implementation call for the necessity of development of its particular versions for students of different training areas.

**The latest research and publication analysis; unsolved problems** Such researchers as A. Andreev, V. Bykov, L. Gozman, V. Kravets, V. Kukhareno, E. Polat, E. Rybalko, O. Spirin, P. Stefanenko, L. Tovazhnyanski, A. Khutorskoi, E. Shestopal and others researched in the distance learning sphere. However, many publications and achievements of national and foreign scientists have not solved the problem of creation of

the complex distance learning system which can be used in professional training of power engineers in the system of higher engineering education.

**The paper goal** is to analyze the peculiarities of the complex adaptive training system for power engineering students and present the partial implementation of the project.

**The main material statement; grounding of the obtained results**

The paper presents the project of the complex adaptive training system for power-engineering students. It is the well-reasoned hypothesis for the future complex training adaptive system.

**The adaptive training system** means the distance learning system aimed at achieving of the student's optimal development level corresponding to his natural inclinations and abilities with taking into account his individual characteristics based on the differentiation of the training methods depending on the student's psychic characteristics and preferences.

The adaptation in the system is double-sided. From one hand the training system is active and adaptation to the individual characteristics of each student [1]. On the other hand the student himself adapts to the system and as a result qualitative changes in his psycho-physiological intellectual and social characteristics take place [2].

A student with his individual peculiarities: natural inclinations, motivation, thinking process, skills and knowledge level, practical and learning activity and independence, studying rate, attitude to learning etc is the reference point in the adaptive system. The adaptive learning is resulted in the qualitative change of the individual peculiarities of the student.

The author developed and implemented three versions of the courses "Mathematical Methods and Models" and "Power Engineering Mathematical Tasks" into the training process at Donetsk National Technical University [3]. The work is aimed at creating of the universal system of application of the artificial intelligence or is a stage to its creation, that is could be the superstructure for the distance learning courses Moodle of the type of BigBlueButton. Further on it will be the ethic algorithm implementation [4].

The project is one of the first implementations of the missing part of the unsolved problem of creation of the interactive personalized training system which is on the right bottom corner of the fig.1.

The scheme in the fig.1 illustrates the evolution of the WEB applications: they were static tables yesterday, today they are the dynamically oriented WEB, and tomorrow it will be the interactive oriented WEB based on knowledge. Catalogues and static files for the development of which the usual HTML editors were used were the sources. As a result the pages with the static text and figures were obtained. Today the sources are data bases and knowledge bases which are developed in the special packages (Cold Fusion, Visual Studio). As a result the pages with the dynamic content are obtained. In the future the creation of the interactive oriented WEB able to implement personal knowledge and generate an interactive dialogue and/or personalization is planned. However, there are no means to create it.

As philosophy preceded all sciences, let us discuss the WEB development stages from the philosophical viewpoints:

- 0 – anticipation of the text;
- 1 – the man gets the text;
- 2 – the man creates the text;
- 3 –the community creates the text;
- 4 –the text creates the man;
- 5 – the text creates the text;
- 6 –what for do we need the man then?

The artificial intellect is getting more and more popular and the perspective absurdity depresses. There is a question: has the information technology vector (which is the consequence of the mankind's development as a whole) been chosen correctly?

If to follow the way the possible result is not difficult to be predetermined. The author, as the project administrator, and his team working at the problem do all the best for this not to happen. We think it is the promising way of the development of technologies and the Internet and the main way of the mankind's development.

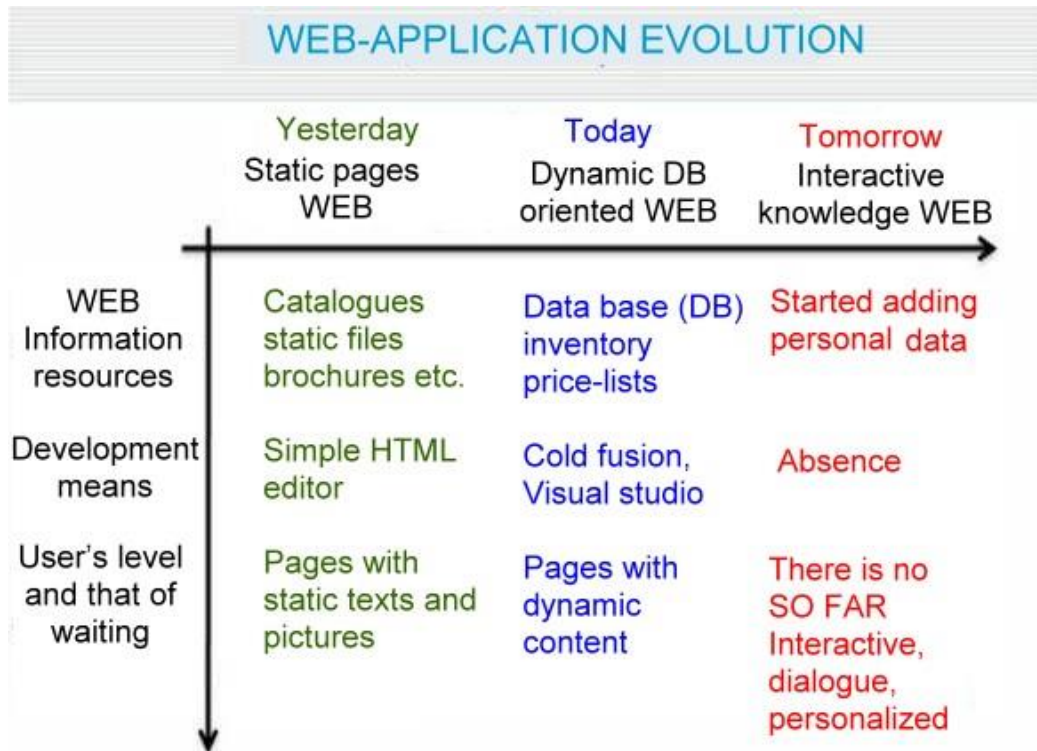

Fig. 1 Classification of the evolution of the algorithms of the distance courses development in the past, present and future

### The prospective phased scheme of the adaptive training system for power engineering students

- Student clustering which is splitting of the student in clusters with the initial characteristics (kinaesthetics, audials, visuals etc).
- Selection of the training adaptive method.
- Testing that extracts the answer context and is based on the knowledge extraction system.
- Making a decision as to the selection of the individual education trajectory.

The project implementation is partially translated into the Python language [5].

The adaptation of the proposed training system is based on the application of the method of L. Szondi, his projective profound and psychological non-verbal test to be exact. The test is aimed at researching of the dynamics of the individual's stimulating structure and his sphere "I" [6]. After getting of the psychological portrait the respondent is proposed the course implementation which is adapted to his personality peculiarities.

Thus the student clustering is based on their psychic characteristics with the application of clusterization algorithms [5]. They are included into the package «Ruby on Rails» (fig. 2).

The author has two servers rented in the USA at his expense. They are domains roerich.com and agni-age.net, where the projects of the distance learning with the application of the artificial intelligence for power engineering students are presented. The control panel is given in the fig.3. The panel controls the site and the domains where the distance learning courses are placed.

The author is also working at the innovation project “Ontological Storage of the Knowledge LYK”. It is a joint with the Institute of the Problems of the Artificial Intelligence of the National Academy of Science of Ukraine project on the basis of which the distance learning system is built. The main goal of the LYK is to collect knowledge on the trainee.

**Manage Ruby on Rails Applications**

*Ruby on Rails Applications are based on the Rails framework. Rails applications must be run like any other application. After creating an application, you will need to populate it with your code. Then, you can choose to start or stop the application and even to load the application every time the server reboots.*

**Create Ruby on Rails Application**

App Name  \*15 character limit

Load on Boot?

Application Path /

**Available Ruby on Rails Applications**

APP NAME	PATH	RAILS SERVER	APP STATUS	ACTIONS	LOAD ON BOOT?	DELETE
No applications present						

**Manage Rewrites**

*Since applications are running on a different port than the other URLs on your server, you'll need to redirect incoming traffic to that port. To do this, you can create a URL rewrite to send users to your Ruby on Rails application.*

**Create A Rewrite**

APP NAME	ACTION
No applications have rewrites	

**Current Rewrites**







APP NAME	REWRITE URL	ACTIONS
No applications have rewrites		

Fig. 2 Entry to the application Ruby on Rails that controls the distance course on the author's domain



The work is carried out at the Institute of the Problems of the Artificial Intelligence in Donetsk that is a subdivision of Donetsk National Technical University. They are planning to build a trainee model based on

Stats	
Main Domain	<b>agni-age.net</b>
Home Directory	/home/agni-ag
Last login from	212.111.200.50
Disk Space Usage	28248.82/∞ MB
Monthly Bandwidth Transfer	27136.69/500000 MB
Subdomains	38/999
Parked Domains	0/0
Addon Domains	0/10
Ftp Accounts	15/999
SQL Databases	2/10
Server Name	host95
cPanel Version	11.30.4 (build 6)
Theme	hrx3
Apache version	2.2.15
PHP version	5.2.13
MySQL version	5.0.92-community-log
Architecture	x86_64
Operating system	linux
Shared Ip Address	216.120.252.101
Path to sendmail	/usr/sbin/sendmail
Path to PERL	/usr/bin/perl
Kernel version	2.6.18-238.12.1.el5
cPanel Pro	1.0 (RC1)
Service Status	Click to View







  

Preferences						
						
Getting Started Wizard	Video Tutorials	Change Password	Manage Account	Change Language	Shortcuts	Get Support





  

Mail		
		
Email Accounts	Spam Assassin™	Webmail







  

Files						
						
Backups	Backup Wizard	Legacy File Manager	File Manager	Disk Space Usage	FTP Accounts	FTP Session Control
	Anonymous FTP					



  

Logs				
				
Latest Visitors	Bandwidth	Webalizer	Raw Access Logs	Error log





  

Security						
						
Password Protect Directories	IP Deny Manager	SSH/Shell Access	HotLink Protection	Leech Protect	GnuPG Keys	Enhanced Access







  

Domains			
			
Subdomains	Addon Domains	Parked Domains	Redirects

Databases			
			
MySQL Databases	MySQL Database Wizard	phpMyAdmin	Remote MySQL

Software / Services					
					
CGI Center	Perl Modules	PHP PEAR Packages	PHP Configuration	Ruby on Rails	SiteBuilder
					
					Fantastico De Luxe









Advanced						
						
Apache Handlers	Image Manager	Index Manager	Error pages	Cron jobs	FrontPage@Extensions	Network Tools
	MTMF					

Fig. 3 Panel of control of the distance course site on the domain of agni-age.net

the project and then to build an expert system of adaptation based on semantic networks.

The usage of the open questions is considered the most promising area in testing within the aspect of the developing project.

The closed questions with the answer options can not fully reflect the trainee's knowledge completeness. The testing is to be carried out with the open questions the answers to which are to be given by the user himself. The computer is to model the pedagogue in full and have his data base and knowledge base.

There is a necessity in the initial recognition of the answer text ( for example with the algorithms of Fine Reader) and further extraction of the knowledge set on the question ( for example with the help of the system SAS Text Miner) and the final comparison of the result with the expert system of the knowledge branch. There are such commercial expert systems but because of their high price (from 0.3 to 5 mln \$) they can not be used in research [7].

**Conclusions and further research prospects** Thus, the paper gives the general scheme of the prospective distance learning system to train students with the application of the artificial intelligence which is partially implemented for the power engineering students. The implementation problems and the scope of work (in the form of evaluation of the cost of some stages) are shown. The analysis of the current artificial intelligence programmes suitable for the application in the distance learning system and development of the expert systems to create the fundamentally new testing systems is the promising sphere. The implementation of ethic algorithms will be the key philosophical moment in implementation of the complex programme of the distance learning with the application of the artificial intelligence.

### **References:**

1. S.U. Goncharenko. Pedagogic Research. Methodological Recommendations to Young Researchers. – K., Vinnitsa, 2008. – 278 p.

2. A.S. Granitskaya. To Teach Thinking and Act: the Training Adaptive System at Schol: the book for teachers. – M.: Prosveshchenie, 1991. – 175 p.
3. S.G. Dzhura. Pedagogic Foundations for the Application of the Artificial Intelligence in the Distance Learning // Proceedings. Series: Pedagogic, Psychology and Sociology. – issue 9 (191). – Donetsk: DonNTU, 2011. - p. 12-23.
4. A.V. Levshov, S.G. Dzhura, V.I. Chursinov. Ethic Algorithms of the Universe // Newsletter SFU – DonNTU. Proceedings of the XI international practical seminar “Practice and Outlook of the Development of the Partnership in High School”. In three books. – Taganrog, SFU Publishing House. Book 1. 2010, №10. – p. 87 – 107.
5. M. Luts. We Study Python. – StPb: Symbol-plus, 2011. – 1280 p.
6. L.N. Sobchick. The Portrait Choice Method – Szondi’s Adapted Test. Handbook. – StPb: Rech, 2002. – 128 p.
7. L.N.Yasnitski.The Artificial Intelligence. Elective Course. Tutorial. – M.: Binom, Knowledge Lab, 2011. - 240 p.

#### **4.11. Programming and pedagogic means Creative Studio PPS 1.0 based distance learning intellectual system for power-engineering students**

O.A. Gudaev, S.G. Dzhura  
Donetsk National Technical University

*The creation of the distance learning intellectual system based on the programming and pedagogic means Creative Studio PPS 1.0 is characterized in the paper. The opportunities to develop different distance learning courses with the application of Creative Studio PPS 1.0 are presented, the programming and pedagogic means function are described and its logical structure is given. The implementation of the distance learning intellectual system in the courses “Mathematical Methods and*



*Models” and “Power Engineering Mathematical Tasks” for higher engineering education institutions is proposed.*

**Key words:** *distance learning, the distance learning intellectual system, programming and pedagogic means, and power- engineering students.*

**The problem general statement; links with scientific and practical knowledge** The topical nature of the research in the distance learning is caused by the full-scale spreading of information technologies in the society and formation of the post-industrial information society. The sustainability of the country is impossible without forming of the national information resources which make up the nation’s intellectual potential /12/.

Education is becoming more and more accessible for all citizens of the planet. The distance education is entering the system of higher education in Ukraine and it requires the development of new approaches as to the application of the artificial intelligence and design of the intellectual systems in the distance learning. The National Strategy of the development of education in Ukraine for the period of 2012-2021 was adopted at the III Ukrainian Congress of Teachers. It emphasized the priority of implementation of modern information and communication technologies that provide improving of the academic and education process, accessibility and efficiency of the education, training of young generation to live in the information society [9, p. 23]. Because of the rapid development of the information technologies the creation of the electron analogue of a teacher with the entire machine (does not forget, impartial, quickly renewable) and human (understand the discussion context, is adaptable to the tutorial, achieves higher marks in training compared with the machine) advantages is in great demand.

**The latest research and publications; unsolved problems.** Many distance learning researchers worked at the distance learning problem. They are V. Bykov, K. Korsak, V. Kukharenko, Y. Pasechnik, E. Polat, V. Rybalko, P. Stefanenko, V. Strelnikov, A. Khutorskoi, and B. Shunevich. They grounded the conceptual foundations of the distance learning and application of the information technologies in the academic process. However, the problem of wide application of the artificial intelligence in design of the distance learning and creation of the courses with the

advantages of the machine and those of man has not been solved yet. The authors obtained some results of the problem research [3-5; 7; 8; 10; 11]. When the Institute of the Problems of the Artificial Intelligence became a subdivision of DonNTU in 2010 the programming and pedagogic complex Creative Studio PPS 1.0 was developed and it offered great possibilities for collaboration.

**The paper goal** is to describe the distance learning intellectual system implemented in the courses “Mathematical Methods and Models” and “Power Engineering Mathematical Tasks” for power engineering students.

**The main material statement; grounding of the obtained results.** The environment of the development of the programming and pedagogic means (PPM) automates the grouping of the training material given to students. The subject matter model description is based on the technologies of presentation of the knowledge by semantic networks. The data storage format is the authorship development of the system of knowledge control «ЛЮИ-ЛЮК 1.0» [1].

The main functions of the Creative Studio:

- 1) formation of the PPM structure by adding and deleting of structural units which are formally called pages and sections;
- 2) filling in the sections with training materials: electron versions of methodological recommendations, course lectures, laboratory tasks, patterns of design of laboratory works in the form of attached files;
- 3) formation of the blocks grouped according to the principle of images and screen forms;
- 4) splitting of the raster image into the meaningful parts which are formed as the semantic network units. The basic concepts of subject area of the training material which are used to make up dictionaries and terms are formed this way;
- 5) forming of the links among the semantic network units within the programme graphic environment that allows automatic generating of illustrated taxonomy;
- 6) entering of the data on copyrights for the training course development into the PPM project: information on the author and training material wrapper, on the subject matter and audience for which the PPM is

written; grouping of heterogeneous data of the project material into the single file data and knowledge base.

Clause 4 (the semantic networks) is of our special interest.

***The programming and pedagogic means structure***

The programme product is the environment of the development of the file container of the heterogeneous multi-media information. The project file contains a set of training materials on the certain discipline. The semantic network is a model of presentation of the knowledge in the created programming and pedagogic means. The PPM structure is visually presented as a tree (fig.1) where the sections are the logic unit of the first level and the pages – of the second level [1].

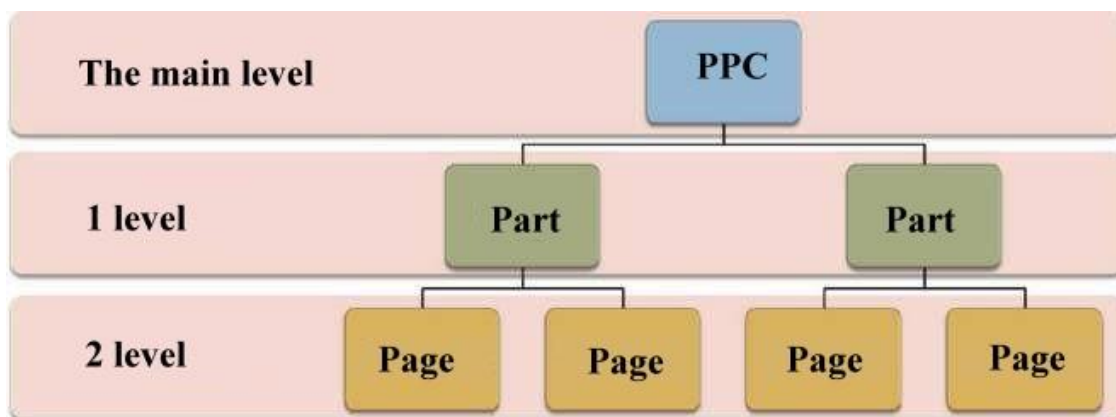

Fig. 1. Logic structure of the programming and pedagogic means

The number of sections is limited and there are 12 of them in general case: “General Information”, “Methodological Material”, “Theoretical Tasks”, “Laboratory Tasks”, “Patterns”, “Questions”, “Software Shells”, “Cards”, “Mark Criteria”, “Work Fulfillment Graph”, “References”.

Each page of the section is the original PPM element which has certain characteristics. The pages can be created, edited, and deleted. There are the following page types (fig.2): 1) *link* – the link to the printed information source or the internet-resource; 2) *file* – the electron documents of presentations, programme pattern exe files, text documents with laboratory work tasks; 3) *screenshot packs* - the set of grouped images and screen forms according to the certain indicators.

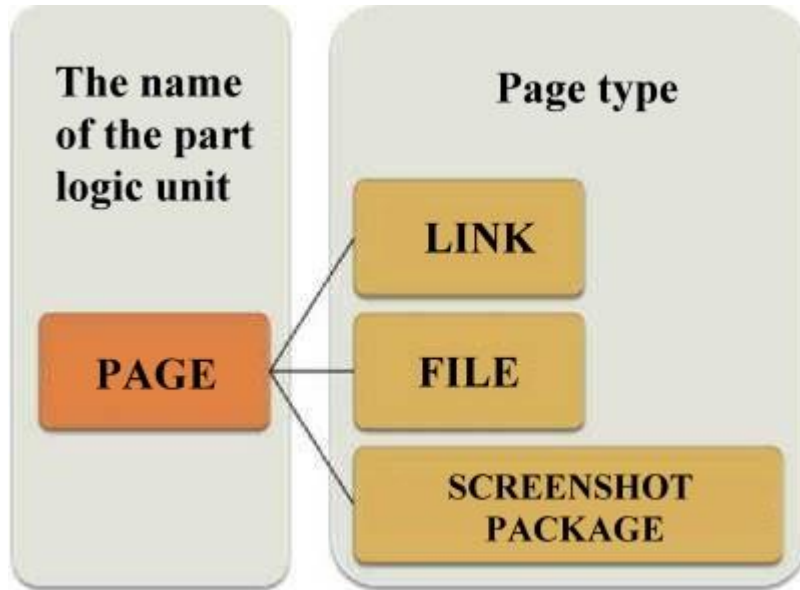

Fig. 2. Section page types

Depending on the choice of the teacher the developed PPM project can contain the section random set.

Depending on the section task some variations of the different page type combination can be added (fig.3). One of the sections, “The General Information” to be exact, has no pages and has the text field “Annotation” [1].

The section title has a certain sense load. The fillin in of the sections is done according to their purpose. The description of the training material in the sections of “General Information” and “References” is simplified to the minimum and only text fields are to be filled in.

Let us examine the work of each of the sections in detail.

The section of “*Methodological Material*” is filled in with the attached electron documents with the lecture courses, methodological recommendations and other training material [1].

The section of “*Theoretical Tasks*” is set aside for the attached files with the individual variants of the themes of essays, theoretical tasks to demonstrate keenness of wit and composition topics. The formats of the attached files can be different – from the office packs to archives.

<b>General Information</b>	
<b>Methodological materials</b>	<ul style="list-style-type: none"> <li>• Screenshot package</li> <li>• File</li> </ul>
<b>Theoretical Tasks</b>	<ul style="list-style-type: none"> <li>• Screenshot package</li> <li>• File</li> </ul>
<b>Laboratory tasks</b>	<ul style="list-style-type: none"> <li>• Screenshot package</li> <li>• File</li> </ul>
<b>Theoretical tasks</b>	<ul style="list-style-type: none"> <li>• Screenshot package</li> <li>• File</li> </ul>
<b>Examples</b>	<ul style="list-style-type: none"> <li>• Screenshot package</li> <li>• File</li> </ul>
<b>Questions</b>	<ul style="list-style-type: none"> <li>• File</li> </ul>
<b>Software shells</b>	<ul style="list-style-type: none"> <li>• File</li> </ul>
<b>Cards</b>	<ul style="list-style-type: none"> <li>• File</li> </ul>
<b>Assessment criteria</b>	<ul style="list-style-type: none"> <li>• File</li> </ul>
<b>Work fulfillment time-table</b>	<ul style="list-style-type: none"> <li>• Screenshot package</li> <li>• File</li> </ul>
<b>Link References</b>	<ul style="list-style-type: none"> <li>• Link</li> <li>• File</li> </ul>

Fig. 3. Splitting of the page types according to the sections

The section of “*Laboratory Tasks*” has sets of laboratory works with individual tasks for students of different groups. The task individual variant has illustrations and can be presented in the form of graphic images grouped in a series called the screenshot pack.

The section of “*Pattern*” is set aside to filling in with the program initial codes, project archives, exe files with text patterns. It can also contain the pattern files of a big size such as the text data base filled in with notes, obtained result tables, output data files which are generated in an automated design system.

The section of “*Questions*” has text documents that contain a list of questions for the exam or the test on the part of the lecture which is studied.

The section of “*Software Shells*” contains the attached files of installation of programme products. If the program shell is placed the keeping to the internet-style is recommended (the single achieve file) when the software is spread.

The section of “*Cards*” can be filled in with the “File” type pages. The text document attached files have frequently asked questions. Sometimes it is reasonable to place the files having several exam cards there. The section can also have recommendations as to oral answers, rules of making up of thesis, semantic summaries and cribs.

The section of “*Mark Criteria*” has a text file with the list of yearly project type assessed in points, the general table on the results of all works according to the curricula. It is also to have the final document of the mark got on the discipline in the mark system accepted by the institution.

The section of “*Work Fulfillment Graph*” has text files with the logic order of the work fulfillment and terms of passing of laboratory works and exams for the certain audience.

The section of “References” has links to the information source in the form of the electron resource or the printed matter. The text document having a list of bibliographic links can be attached to the section. Besides, the links to the printed or Internet matters can be added by filling in of two fields- “Text” and “Annotation” [1].

**Application of the PPM in training** The PPM project developed by the Creative Studio is aimed at facilitating of teaching for academics and school teachers. The PPM project created for one discipline might be widened and modified. The knowledge base format LUi -LYK allows spreading of the modification by a single pack of updating loaded through the Internet. The PPM training material will be supplied to the students with the help of a browser programme (fig.4) [1].

Two files (lyk, lui) are saved in the Creative Studio. They are a container to keep electron data on all the PPM sections which is one of the

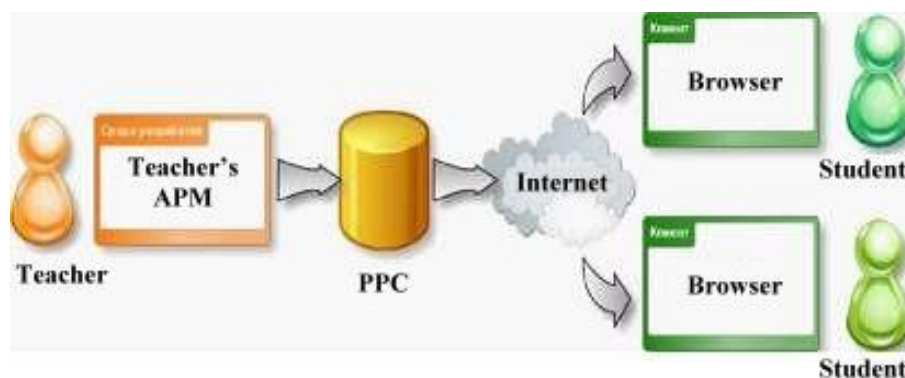

Fig. 4. The container to keep the electron data

most important arguments in favour of the dissemination in the Internet. The user, be it a teacher or a student, is not to worry what and where is to be looked for due to the form of the material keeping. All the training materials are presented in a compact form. The files are easy to transfer into the information keeping portable devices [1].

**Implementation of the course “Mathematical Models and Methods”** was done on the mentioned PPM. It is delivered to the power engineering students of DonNTU. The course photo is given in the programme shell in the fig. 5.

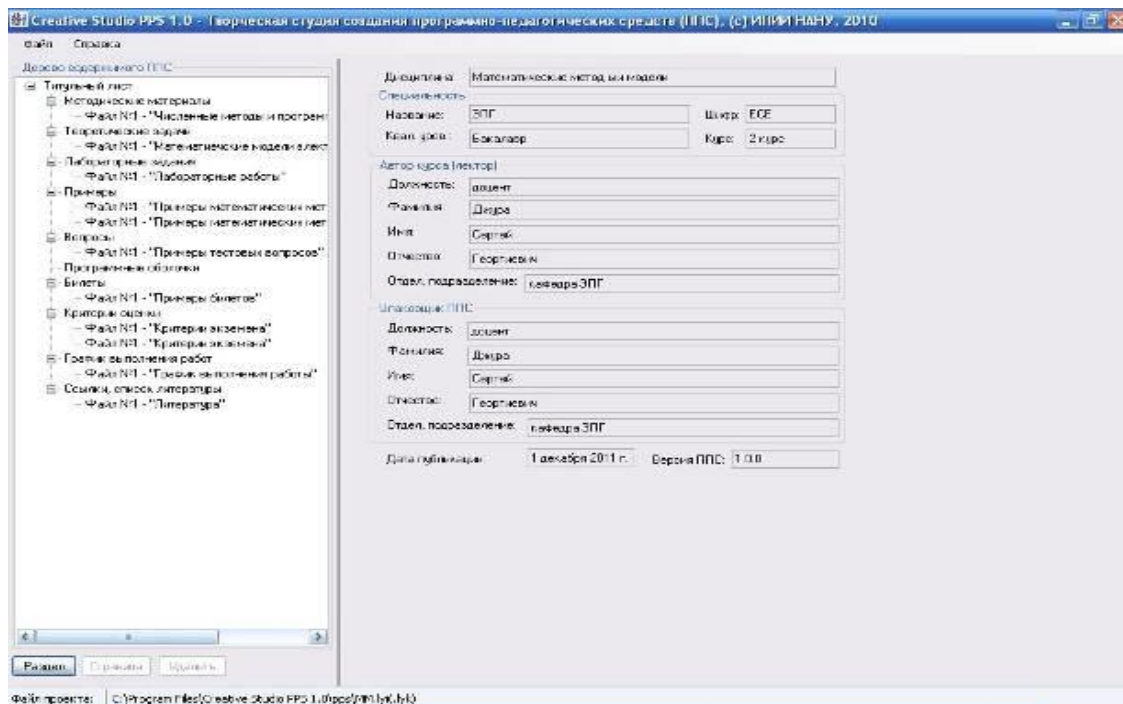

Fig. 5. Picture of the course in the teacher’s training programme

The students are offered the metafile browser and the course has a form given in the fig. 6. Figures 7, 8, 9, 10 illustrate the further work in the pack to get the semantic network. The network allows visual presentation of the links among the main concepts which are the network units. To decode the obtained information the unpacker LYKSemanticNET.exe is used [2]. Its work results are presented in the fig. 11-12. Then the semantic network picture can be saved as a file with the extension of \*.BMP with the following printing or transforming into other necessary format. The network makes orientation in the course questions easier and finding of the logical links presented in the picture. Thus, the machine does a part of the

work instead of man and in such a way helps him to be concentrated on the main issue. The development of the ideas is given in the works [6; 13].

The screenshot shows the 'PPS Guide 1.0' interface. The main window is titled 'Содержание курса' (Course Content). It features a table with columns '№' (No.), 'Раздел' (Section), and 'Кол-во страниц' (Number of pages). Below the table is a pie chart titled 'Наполненность разделов страницами' (Page distribution by section) with labels for each section's page count.

№	Раздел	Кол-во страниц
1	Методические материалы	0
2	Лабораторные задания	1
3	Методические материалы	1
4	Вопросы	1
5	Критерии оценки	1
6	График выполнения работ	1
7	Ссылки, список литературы	1
8	Программные оболочки	0
9	Теоретические задачи	1
10	Примеры	1
		Итого: 9

The pie chart labels are: Вопросы (1 стр.), Методические материалы (1 стр.), Лабораторные задания (1 стр.), Программные оболочки (0 стр.), Ссылки (1 стр.), Примеры (1 стр.), Теоретические задачи (1 стр.), Программные оболочки (0 стр.), График выполнения работ (1 стр.), Критерии оценки (1 стр.), Вопросы (1 стр.), Методические материалы (1 стр.).

Fig. 6. Browsing of the course in the student's programme

The screenshot shows the 'ЛЮКСет 1.0' interface. The main window is titled 'Развертывание семантической сети ЛЮК на базе таблицы первичных онтологий, (с) 1 удаев О.А., 2009 г.'. The main area displays a list of ontologies with their IDs and names.

000A200	Делител
000A200	Дуга
000A200	Множ
000A200	Множ
000A400	Полос
000A500	Сфера
000A500	Комплекс
000A700	Облачение
000A800	Датализация
000A900	Истина
000A1000	Слой эрности нетка
000A1100	Самостоятельный аргумент нетка
000A1200	Цифровая функция нетка
000A1300	Возвращение нетка
000A1400	Образовательная нетка
000A1500	Создаваемая нетка
000A1600	Слой
000A1700	Обложка
000A1800	"Дополн" именованных данных
000A1900	Шероха данных
000A2000	Комплекс
000A2100	Самостоятельный элемент
000A2200	Вспомог
000A2300	Добавить в конец
000A2400	Добавить в начало
000A2500	Целый
000A2600	Вспомогательная нетка
000A2700	Модель задачи (Добавить-Вставить)
000A2800	Логические слои
000A2900	A - Аксиом
000A3000	B - Объект
000A3100	R - Прямик
000A3200	S - Организация
000A3300	F - Функция
000A3400	VF - Предметная функция
000A3500	CL - Самостоятельный логический объект
000A3600	LD - Не самостоятельный логический объект
000A3700	Компьютерная сеть
000A3800	Страница 236.html
000A3900	Целый число
000A4000	Веществоное число
000A4100	Дата и время
000A4200	DJLD-код

Fig. 7. Decompression of the logical network on the basis of the table of initial ontologies



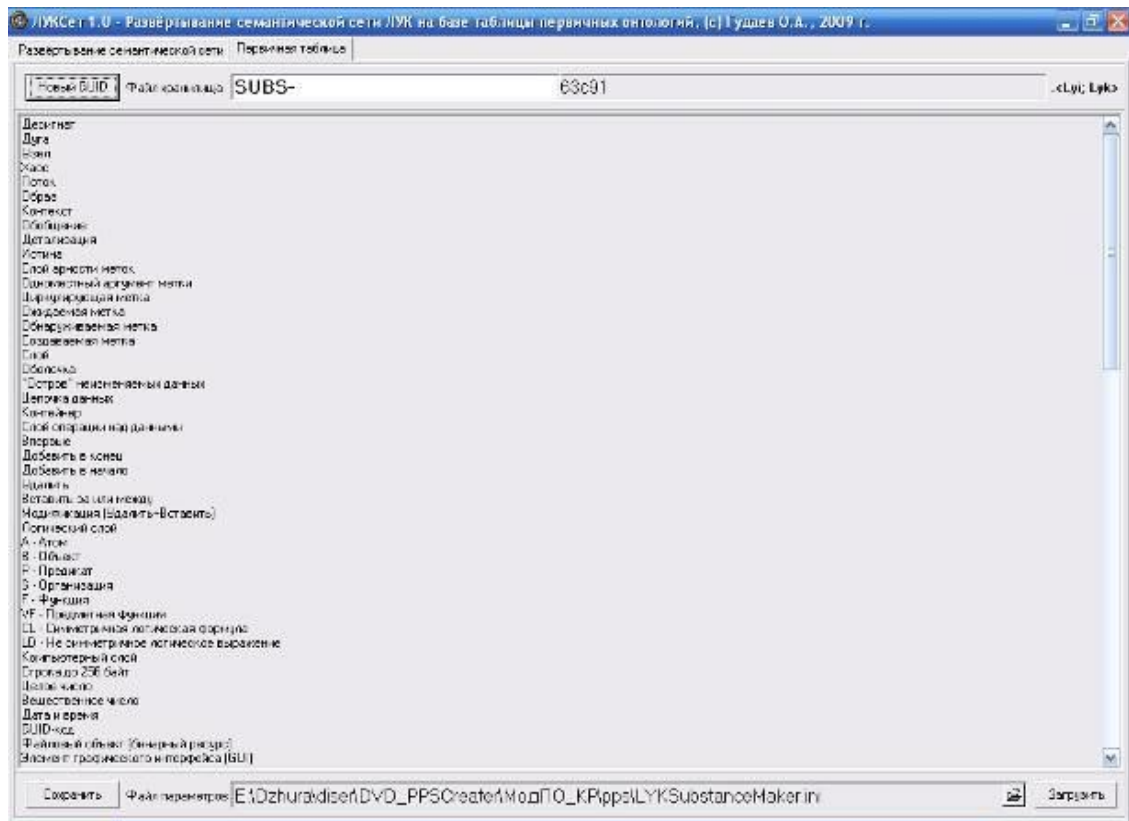

Fig. 8. Initial table of the semantic network LYK

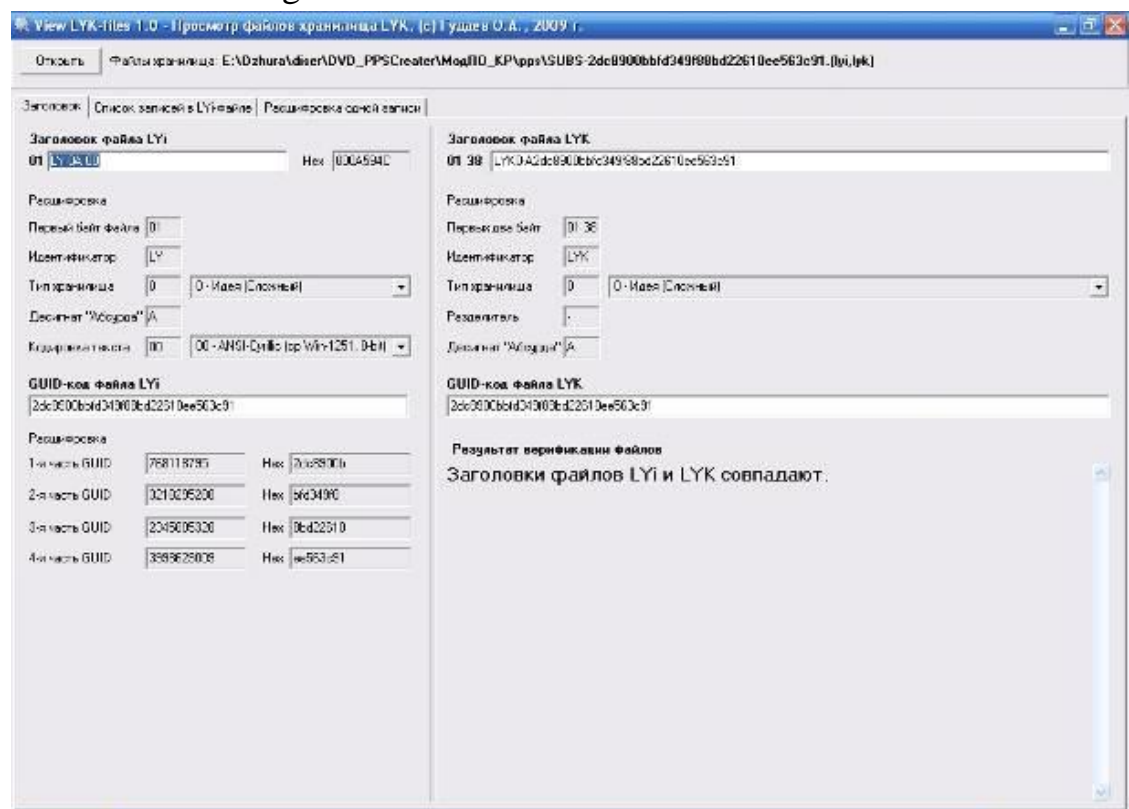

Fig. 9. Browsing of the files of the LYK storage

View LYk-files 1.0 - Просмотр файлов хранилища LYk, (с) ИИИИ О.А., 2009 г.

Открыть: Папки хранилища: E:\Dzhura\disker\DVD\_PPSCreator\Mod\ID\_KP\apps\SUBS-2dc6900bfd349f88bd22610ee563e91.lyk

Заголовок: Список записей в LYk-файле | Расшировка своей записи

Только концепты  Все записи

LYk-адрес	Select	Link	Reference	// \$Link[1..6]
0		070220	0	000A50
65	1	42600	40	000A00
70	1	41210	62	000A01
91	1	41472	74	000A02
104	1	41726	85	000A03
117	1	41894	88	000A04
130	1	42240	111	000A05
143	1	42496	124	000A05
156	1	42752	140	000A07
169	1	43008	157	000A08
182	1	43264	176	000A09
195	1	626406	190	000A10
208	1	626712	216	000A11
221	1	626968	230	000A12
234	1	631224	277	000A13
247	1	631480	300	000A14
260	1	631736	326	000A15
273	1	631992	352	000A16
286	1	631248	365	000A17
299	1	631504	391	000A18
312	1	631760	417	000A19
325	1	632016	439	000A20
338	1	632272	456	000A21

Fig. 10. List of notes in the LYk file (only concepts)

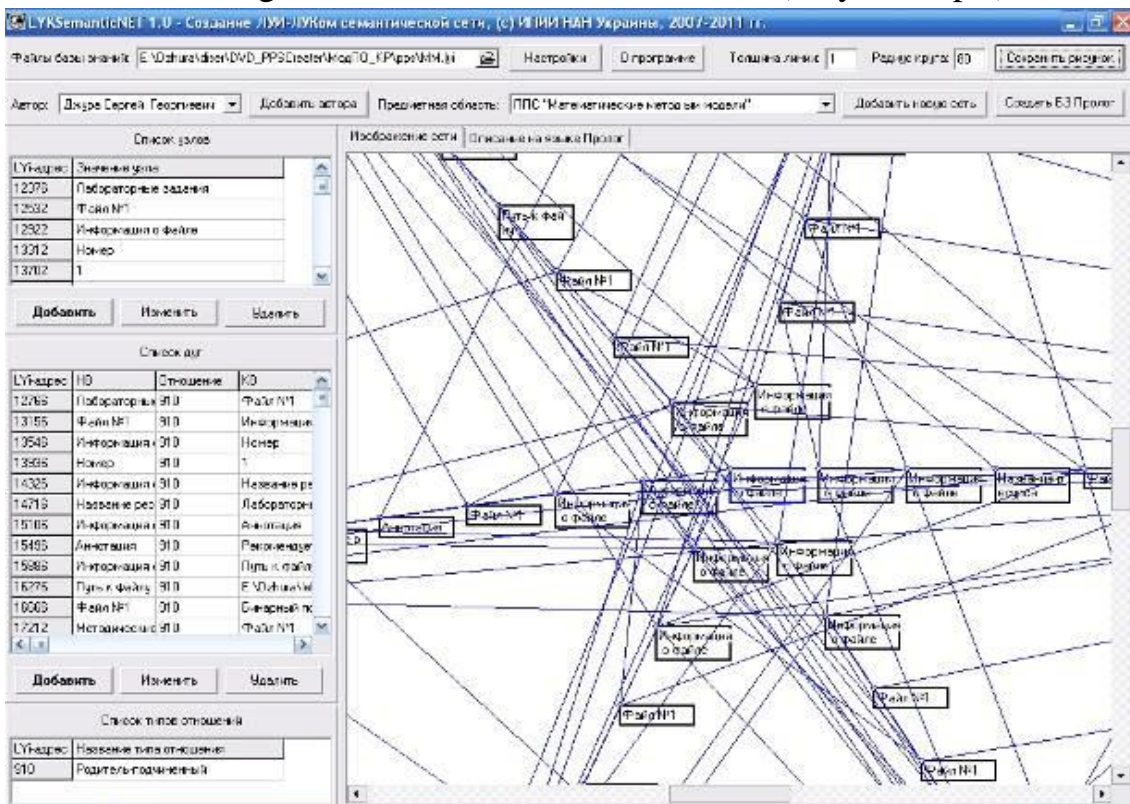

Fig. 11. Presentation of the semantic network in the browser programme

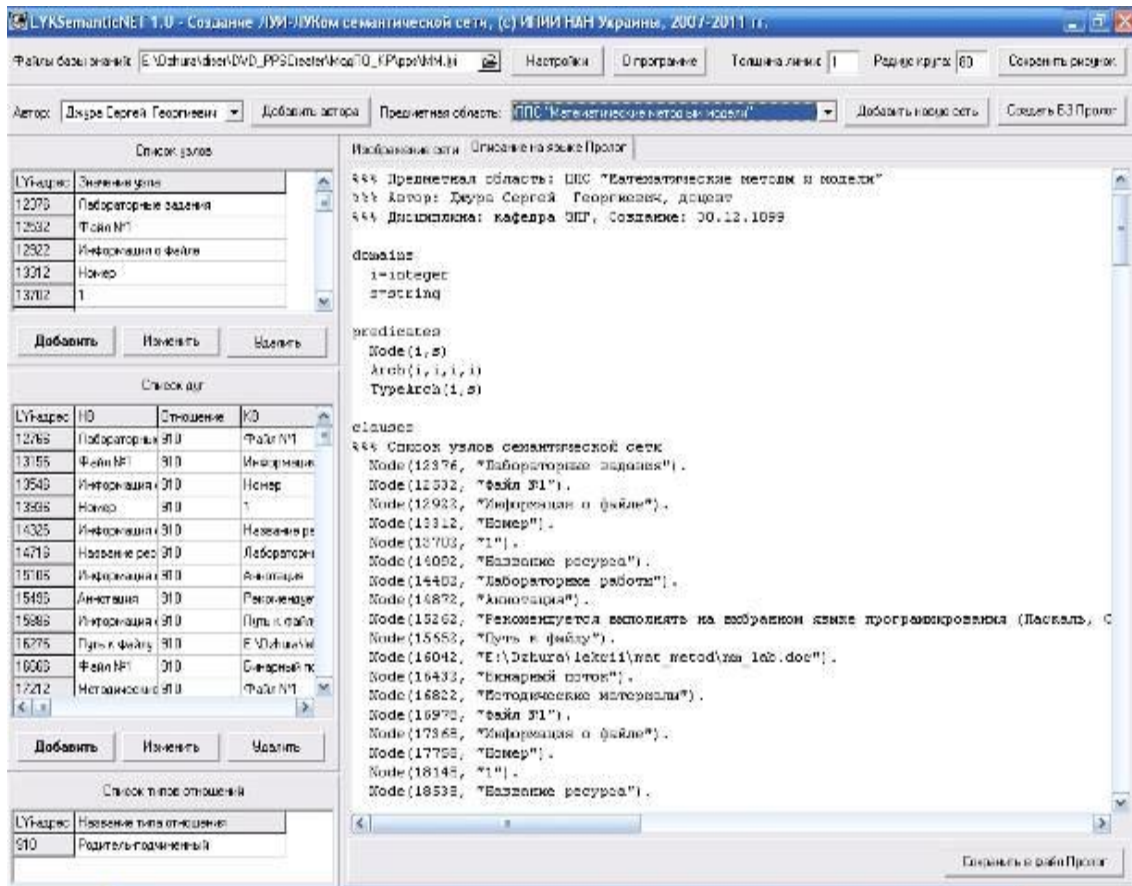

Fig. 12. Presentation of the semantic network as Prolog programme

**Conclusions and further development outlook** Thus the programming and pedagogic means Creative Studio help develop the distance learning intellectual systems for different disciplines which is shown on the examples of the courses “Mathematical Methods and Models” and “Power Engineering Mathematical Tasks” for power engineering students. Improvement of the semantic network, its presentation and integration into the developed courses is promising for the research.

#### References:

1. A. V. Boiko, N.M. Korotych, O.A. Gudaev. Methods of Creation of the PPM Creative Studio PPS 1.0 – Donetsk: DUAИ, 2010. - 32 p.
2. O.A. Gudaev. Methodological Recommendations to Make Calculations on the Discipline Functional and Logical Programming. – Donetsk: DUAИ, 2011. – 15 p.

3. S.G. Dzhura. Pedagogic Foundations of Application of the Artificial Intelligence in the Distance Education // Proceedings. Series: Pedagogic, Psychology and Sociology. – Issue 9 (191). – Donetsk, DonNTU, 2011.- p. 12-23.

4. S.G. Dzhura, V.K. Trofimyuk. Formation of the Knowledge New Paradigm// Proceedings of the IX interdisciplinary scientific conference “Ethic and the Future Science” - The Knowledge Paradigm and Education. – M.: Delphis, 2010. – p. 78-82.

5. S.G. Dzhura, V.I. Chursinov, A.A. Chursinova. The Distance Learning of the Future: the Artificial Intelligence Gives New Possibilities// Engineering Education in the Development of the Modern Society: Proceedings of the international scientific and practical conference. Donetsk, May 30<sup>th</sup> –June 1<sup>st</sup> 2011. Donetsk, DonNTU, 2011. – p. 174-194.

6. H.M. Korotych, S.B. Ivanova, O.A. Gudaev. Architecture of the Intellectual System of Monitoring of the Distance Learning Process on the Basis of the Wider Reality / Supervisor: A.I. Shevchenko// Modern Informational Ukraine: Information Science, Philosophy and Economics. Proceedings of the III international scientific and practical conference, Donetsk, May 14-15 2009. Donetsk. – 2009.- vol. 1. – p. 199-202.

7. A.V. Levshov, S.G. Dzhura, V. I. Chursinov. The Distance Learning on the Stage of Formation of the Noosphere Thinking// Proceedings of the IX interdisciplinary scientific conference “Ethic and the Future Science” - The Knowledge Paradigm and Education. – M.: Delphis, 2010. – p. 128-144.

8. A.V. Levshov, S.G. Dzhura, V. I. Chursinov. Outlooks of the Application of the Artificial Intelligence in the Distance Learning at the Modern Stage. // Proceedings of the XVIII international scientific and technical conference “Mechanical Engineering and Technosphere of the XXI Century”. vol. 2. – Donetsk: DonNTU, 2011. – p. 153- 157.

9. The National Strategy of Development of Education in Ukraine for 2012-2021. <http://mon.gov.ua/images/files/news/12/05/4455.pdf>

10. P.V. Stefanenko, S.G. Dzhura, V.I. Chursinov. Peculiarities of the Distance Learning at the Noospheric Stage of Development // Proceedings. Series: Pedagogic, Psychology and Sociology. – Issue 7 (167). – Donetsk, DonNTU, 2010. - p.33- 47.

11. P.V. Stefanenko, S.G. Dzhura, V.I. Chursinov. Peculiarities of Application of Artificial Intelligence in the Distance Learning // Proceedings of the XVII international scientific and technical conference “Mechanical Engineering and Technosphere of the XXI Century”. vol. 3. – Donetsk: DonNTU, 2010. – p.122-124

12. Theory and Practice of the Distance Learning. Tutorial / E. Polat, M. Bukharkina, M. Moiseeva; Edited by E. Polat. – M.: Publishing Centre “Academy”, 2004. – 416 p.

13. A. Shevchenko, O. Gudaev, S. Nekrashevich. Design of the System of Monitoring of the Distance Learning on the Basis of the Artificial Intelligence // The Artificial Intelligence. – 2010. - № 1. – p.11 – 20.

#### **4.12. Pedagogic fundamentals of the artificial intelligence application in the distance education**

O.M. Spirin, S.G. Dzhura

The educational world and the community as a whole suffer from heart failure and heartlessness. The pedagogic garden fades and withers without the heart life-giving water. The pedagogic consciousness wanders in the labyrinths of the three dimensional science for which the concept of the heart is meaningless words  
St. John of Kronstadt

*Implementation of the distance learning course “Mathematical Methods and Models” for the distance learning different systems is analyzed. The place of pedagogic in the human sciences is analyzed. The tendencies of development of the modern state of the distance education are shown. The choice of the training system which allows using of the artificial intelligence in the training process is reasoned.*

**The research task statement** The paper examines the global view on the development of pedagogic and possible implementation of the distance learning. The problem is that the pedagogic thought research is aimed at the mankind’s cognition development in the widest aspect. The

knowledge can be compared with the double-edged sword, one part of which serves the mankind's evolution and the other one – the mankind's involution. Many philosophers have written about it. The leading screenwriter of nowadays Mr. Yuri Arabov wrote: "The science which is not able to guess its destiny and that of other people and is unable to answer the basic questions of the being (Why do we live? What happens after our death? Why does the event happen to us? What drives happiness? ) is not worth a brass farthing". That is the problem of responsibility for what is taught is the crucial one. The man is to be worth of the knowledge he is going to get. It is a super task. When we hear that the scientific knowledge is always good we recollect the sarcastic remark of F. Nietzsche: "There is always Paradise where the tree of knowledge is, the most ancient and latest snakes say". Not everything that we know can belong to strangers because of different reasons: for it not to belong to evil and ignorant hands, for our country not to pay foreign dealers for our own ideas (it has happened many times). Not all the ideas are patented abroad. That is the knowledge serves both good and evil in the global sense. The famous expression "There is much sorrow in much knowledge" originates from it. The expert who has not taken in cultural fundamentals can cultivate both good and evil. Computer viruses are bright examples of it. In this case the probability of the negative result is much higher (the Internet traffic leads to the involution resources). Thus what does pedagogic serve? Is it to increase the power of forces that lead the mankind to the involution? The authors think that the teaching option is to be selective as the civilization vector has been lost. All types of crises which are frequent now prove it. Thus **the problem number one** is as follows: how pedagogic can help find the mankind's development correct vector. The problem is not easy and involves not one institute of strategic solutions. However, it is to be stated and solved. **The problem number two**: how the information technologies can help solve the problem number one. The paper examines the problems in brief. They are so topical that delay (in the form of monograph writing etc) can not be excused. The scientific tasks mentioned in the paper are so big that, as the truth, can not be covered by any science, philosophy and a religious system. They are only slightly reflected in the form of the truth sides. We will try to find them.

**Pedagogic development vector** Let us examine the place of pedagogic in human sciences and the evolution process. It is the most suitable point of view to find the optimal way of teaching, upbringing and education, which pedagogic as a science consists of. The being development vector /1/ is shown in the fig. 1. The place of pedagogic is subjected to the sense of man's existence here. Different schools and religions define the sense of man's existence differently. We support the idea that it consists in his improving, his feeling finesse and his thought rise. The /2/ says: "Perfection, that is the spirit rise, is the only goal of the evolution under any condition. There is the sense of life in it, it should be always remembered".

**From art to a technology** Science is developed from art to a technology. Genesis of any branch of science shows it. The quotation from the journal "The Artificial Intelligence Problems" illustrates it /3/: "The forefront of science connected with creative and intuitive processes has always been similar to big art. The roles of a scientist and an artist are the same. Their mission is to see the things that others are unable to see and transfer what is open to the level accessible to others. The vision sides and means of the transfer are different, but they have much to learn from each other". We think that pedagogic as a science is not an exception. We will try to examine the stages that can be automatized. It is not a secret that man's laziness forces implementation of machines in many branches of man's life. Thus the man invented a wheel one day and entrusted his problems to the machine. Now we have computers that "think" instead of "the man" and the man tries to entrust his pedagogic work to computer "shoulders". But not only had this made us write. The avalanche of growing knowledge gives no chance to the mankind to transfer the knowledge but to use the modern computer technologies. The words of the famous Russian pedagogue K.D. Ushinski are topical: "The art of upbringing is characterized by the fact that everybody thinks it is familiar and easy. The less man knows about it in theory and practice the more understandable and simple it seems. Everybody acknowledges that upbringing needs patience. Some people think that it requires some natural abilities and skills. And only a few are sure that besides the patience, abilities and skills it needs special knowledge" /4. Now the computer can broadcast the knowledge and it is not short on the patience. That is why

people see big advantages in using computer technologies in a pedagogic activity. As the artificial intelligence (AI) is the forefront of computer technology development the society has high hopes for it.

Let us examine it in a dialectical unity. That is what can be automatized from the point of view of pedagogic and which are the achievements of the AI and what can be used from the point of view of the technology.

**Where the AI can be used from the point of view of pedagogic**

The modern education is developing in different directions and is characterized by the following features: humanization, orientation on the achievement of humanities, differentiation, diversification, standardization, diversity, many levels, fundamentalization, computerization, individualization, continuity. In this case the application of the computers is most logical in the following features:

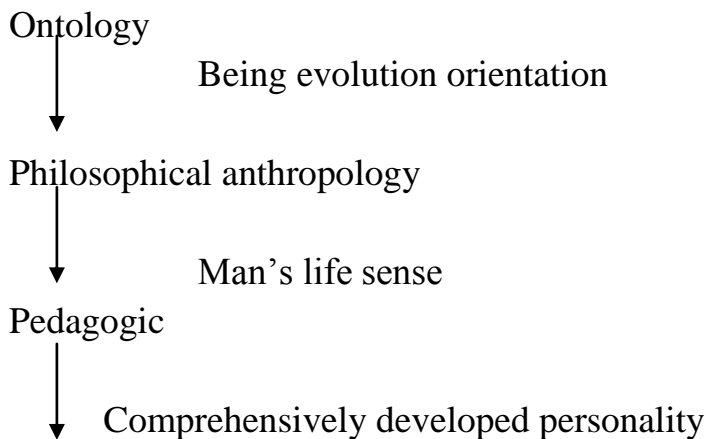

Life practice

Fig. 1. Place of pedagogic in the human sciences rank

- **Education informatizing** is connected to the wide application of computers and information technologies in the man's training process. It became widely spread during the last ten year's period because of accessibility of the system of education and simplicity in the usage of the modern audio and video facilities and computers.

- **Individualization** is taking into account and development of individual characteristics of students in all forms of interaction with them in the process of training and upbringing.



- **Continuity** does not mean the education that was got once and forever, but the process of **continuous learning and self-learning during all life period** because of the life conditions that are quickly changed in the modern society.

After analyzing of the new tutorial on pedagogic /5/ we can sort out the following sections and stages of the pedagogic activity where it is possible. We think that the AI can be applied while modeling of

- 1) training different styles and types;
- 2) before any of the training styles is applied the student is to be tested (the individualization principle). It can be a separate research section. K.D. Ushinski emphasized topicality of it: "...if pedagogic wants to bring up a man in all aspects it is to learn him in every respect first of all". It can be his motion function (that is whether he is a visual, an audial or a kinaesthetic and in accordance to the result use a lecture-visualization or other method).
- 3) a gnostic, constructive, organizational, communicative, diagnostic, correcting or testing and assessing function of a pedagogue;
- 4) different didactic systems: developing, problematic, module programming teaching;
- 5) a pedagogic qualimetry and modeling;
- 6) a teaching reproductive style the main characteristic of which is to transfer a number of obvious knowledge to the students. The pedagogue just states the material and checks the level of its learning. The main type of the teacher's activity is the reproduction that admits no alternative. Only regulated or dogmatized knowledge is taken into account in the frameworks of the model. The students' opinion is not considered. The system of the requirements of the teacher to the quick, accurate and lasting learning of the knowledge and skills is the fundamental principle of the reproductive learning. It is carried out in the form of a monologue: "repeat", "recur", "remember", "do according to the pattern".
- 7) educational technologies. It is a system of activity of the pedagogue and his students in the educational process built on the

certain idea and in accordance with the certain principles of organization and interrelation of the goals and method contents. Schools, universities and other educational systems use different types of the education technologies.

- 8) social relation organization types in the training process. The fourth type “a teacher-training means-a student” is the characteristic of the distance learning (with the help of the computer and other technical facilities) when there is the indirect contact between the teacher and his student.
- 9) the training paradigm concept. The idea of it is in the fact that the material to learn is to be presented not in a systematic way but in a focus one (without observing a historical and logic consequence) with the emphasizing of typical facts and events. The material is to be presented on the basis of the examples instead of continuous statement of it. The whole is understood through the profound analysis of a single fact, phenomenon or event. The weak point of the concept is that it breaks the principle of systematic presentation of the material. That is why the approach is not acceptable for the disciplines with the material linear structure (mathematics, for example).
- 10) the training cybernetic concept. The representatives of the school (S.I. Arkhangelski, E.I. Mashbits) consider the training to be the process of the information transfer and processing. That is they absolutize the role of the information and the mechanisms of its learning. They underestimate the significance of the logic and psychological and individual characteristics of the subjects of the training process. The information and system theory and cybernetic laws of the information transfer are the methodological basis of the field.
- 11) modeling of the constructive, organizational and communicative functional component of the teacher’s activity. There are many variants of application of the system common theory in the pedagogic activity analysis. Thus, N.V. Kuzmin introduced the idea of the pedagogic system and singled out not only its structural components but functional elements too. There are five structural components of the model: 1) the pedagogic

influence subject; 2) the pedagogic influence object; 3) the field of their joint activity; 4) training goals; 5) means of pedagogic communication. In fact, the mentioned components make up the system. If one of them is removed, the pedagogic system will break. On the other hand not a single component can be replaced by other one or a group of other elements. To single out the structural component does not mean to give a complete description of the system. To state the system we need not only to reveal its elements but also to find the links among them. All structural components of the pedagogic system are in direct and reverse dependence in this case. The central scientific task of pedagogic and pedagogic psychology is to show how the system components depend on each other (we are looking for the place of the AI technology). While working at the problem of the pedagogic activity N.V. Kuzmina stated the teacher's activity structure. There are five functional components in it: 1) gnostic; 2) design; 3) constructive; 4) organizational; 5) communicative. The components 3, 4, and 5 can be successfully applied when modeling on the modern computers with the help of the AI.

- 12) knowledge checking (testing). The higher school needs new methods of control which are time- economical. These are tests first of all. They can be regarded as an addition to the traditional technologies as according to the fundamental work on the test theory/6/ “ there is a reason to think that the testing like all other tools to assess the learning achievements does not allow reliable recognizing of the phenomenon of students' understanding of the material. Understanding is deep in the human psychic and can be assessed only after a long personal contact between the teacher and the student. In other words if there is understanding among people they recognize the fact of understanding or misunderstanding of the discussed subject intuitively. It is one of the crucial aspects of the human communication that motivates us to discuss serious life problems to the face of each other”. However, the test theory is being developed and the book /6/ pays much attention to the task analysis, pedagogic measurement result quality, their validity and reliability, the test standardization and

getting of their norms. The methods of scaling of the data on pedagogic measurements and leveling of the scale of marks obtained in different tests.

**Interim conclusion** A personality is an object of the pedagogic activity and the latter is organized in accordance with communication laws. There are three components in the communication structure two of which (cognitive and affective (emotional) can be implemented with the help of the AI. One of them is the activity functional product (a lesson, class, method). The other one (and the main) implies the activity psychological products (psychic new growths in the student's personality). In other words, the student, his personality, skills and competence development is the main and final result of the pedagogic activity. As every student is a unique personality, the effective pedagogic activity is a creative one. This can be used in the AI. Now we are going on discussing the concepts and methods where the AI can be used. It is the modeling of

- 13) behavioural function of the student;
- 14) vicarious learning which is connected with getting of the social experience at the expense of the learning of others;
- 15) the intrapersonal level which is self-upbringing which is the upbringing influence of the man on himself in different life situations. For example in those of choice and conflict, while doing tasks and taking exams or during sports competitions.
- 16) polycultural upbringing (the Internet helps do it now).
- 17) the main educational function which is transfer of the knowledge and cultural values accumulated by generations. It is also implemented by the Internet; you only need to know how to choose the necessary information.
- 18) student's choice as to his individual way of the course learning;
- 19) implementation of the ancient Russian function of upbringing by the community.
- 20) fulfillment of the function of the education humanization which is orientation of the education and the education system on the development and forming of mutual respect among the teachers and students based on acceptance of the rights of every

person, taking care of their health, proper pride and personal potential development.



Fig. 2. Starting page of implementation of the course “Mathematical Methods and Models on SMS Joomla 1.5.

Only this type of education guarantees the students the right to choose the development individual way (which can be also implemented in the AI). It can not be used in the divided programme of the modern courses of the training information.

We are aware of the fact that not everything can be automatized today, but the given list covers a wide sphere of its implementation.

**The project preliminary results** First the course was introduced in 2008 /7/. It is still being supported and improved /8-11/. The starting page is shown in the fig.2.

We did not manage to get the complete implementation of the possibilities of the AI though there are some advantages. The students' progress and course management within the organization were not observed automatically. Good presentation of it is given in the modern Learning Management Systems. The monograph /12/ gives comparative analysis of them with taking into account the application of the artificial

intelligence. The priority is given to the system Moodle 1.9.9. The team work /13/ has the same opinion.

The next approximation was the application of the mentioned system to implement the course “Mathematical Methods and Models” for power engineering students. It was implemented in the frameworks of the refresher courses organized by academics from European universities at DonNTU. The participants got certificates. The certificate that acknowledges the defense of the course in presence of the international commission under the aegis of the Agency of French Speaking Universities is shown in the fig. 3.



Fig. 3. The Certificate of the International Agency of the French Speaking Universities on the defense of the course “Mathematical Methods and Models” for power engineering students.

However, the possibilities of the training system LMS Moodle had become traditional and the search was going on. It is not able to individualize the education and implement other important aspects mentioned above. The third approximation was creation of the same course in the system Authorware 7.0.1 the previous version of which is described in the book /14/.

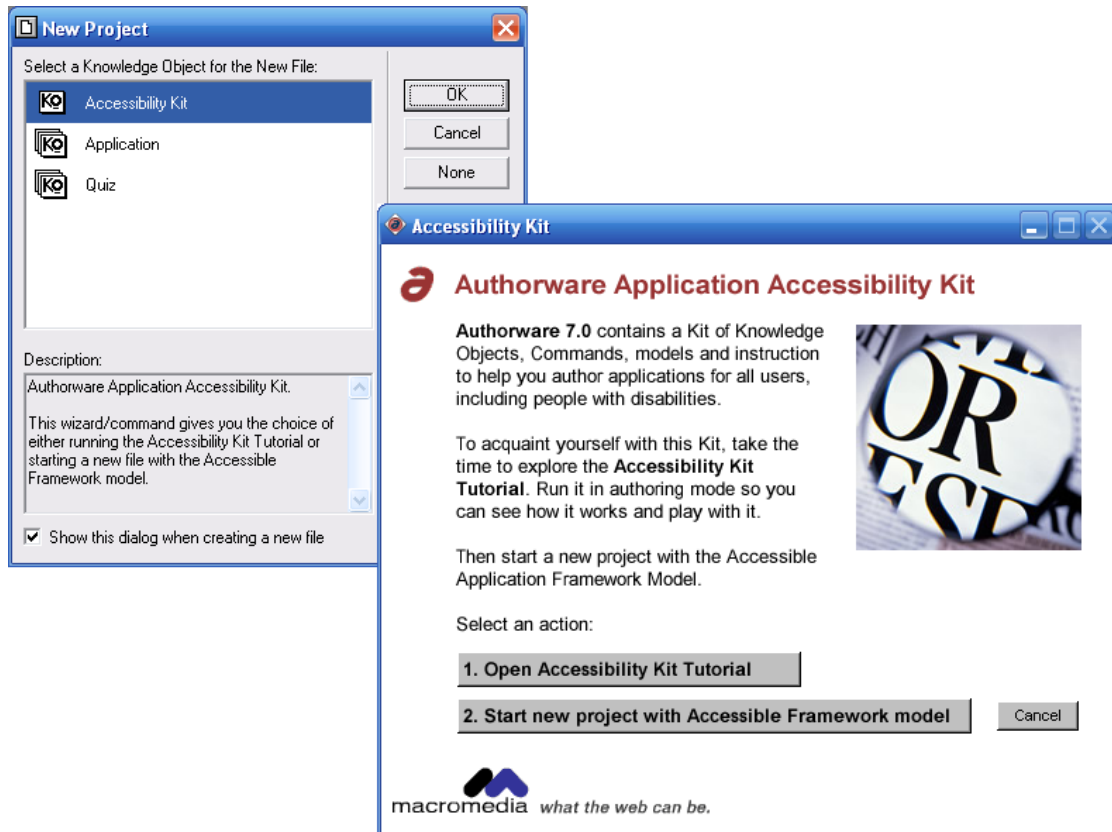

Fig. 4. The starting menu of Authorware 7.0.1 on which the course “Mathematical Models and Methods” was implemented

What new features does our version 7.0.1 have in comparison with the version described in the book? They are as follows:

- the LMS includes KO (knowledge objects) implemented in the standard AICC/SCORM that allows them integrating into other LMS built in accordance with the standard of the distance learning AICC/SCORM.
- there is the environment object tracing;
- it allows using Power Point drafts and documents saved in the xml format;
- it allows starting up of JavaScript engine that makes it multi platform and automatizes many processes with external calculations (text processing, calling of training programmes written in other systems but exported into the format);
- it connects external DVD and other video and media libraries and playing data formats;
- it supports the external sound formats that allows implementing of audio courses;

- it has the improved user's interface. Unlike the previous version there is a chance to modernize the helper during the startup which can guide the user on all peculiarities of the course and prompt what to do and how (it is Accessibility Kit). The previous version did not have it, though two previous menus (Application and Quiz) were preserved. The starting menu of the pack is shown in the fig. 4.

There were some organizational difficulties as the pack is quite expensive for Ukraine (5 000 \$). However there is 30 day's trial version. The pack is hard in training and not everything in it works as stated (for example while RTF files are imported tables are lost). Nevertheless if the user has some skills he can work with it. The course can be saved in the pack internal format, HTML and EXE. It is convenient to display the information in the Internet in HTML, and record (or download) it on the discs in the EXE format. There are no specific super intellectual possibilities in the pack though it was stated as "the distance education modern standard". The pattern of the starting and training boxes is given in the fig. 5 and the working area of the training programmes created in the pack is shown in the fig. 6.

The course consists of 6 sections and subsections and there are tests after each of them. The tests are processed by a separate programme. We were unable to discover everything stated by the programme, so the search is going on.

**The distance learning modern intellectual systems** These are Adaptive educational hypermedia - AEH, Intelligent tutoring system - ITS that use the directives of SCORM (Sharable Content Object Reference Model) which is the collector of specifications and standards developed for the distance learning systems and contains requirements for the training material and the distance learning system organization. We would like to speak about the most interesting ones from our point of view /15-19/.



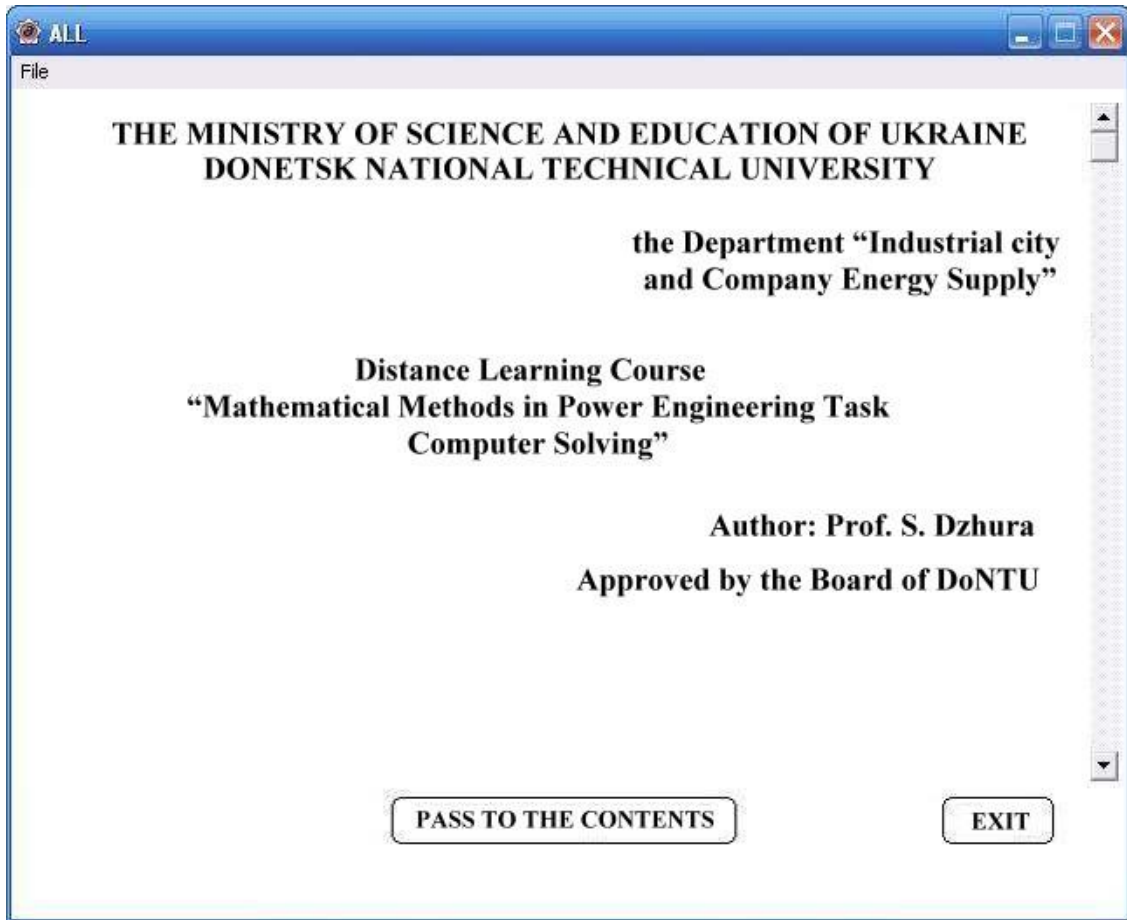

Fig. 5. The starting page of the local version of the distance course "Mathematical Models and Methods" created in the system Macromedia Autorware 7.0.1.

It can be presented as the following scheme. The instructor model is radially connected with the student's model, the expert model, the training system and training modeling. How will the project be implemented in the future? What has been done in this field in the world? The analysis shows that each stage of the application of the AI in the distance education can be recorded in the form of a doctoral dissertation. The doctoral dissertation /20/ is devoted to the user's autotentification; the dissertation /21/- to the application of the neural networks in training, the dissertation 22 – to the application of self-educated algorithms on the basis of Bayes theorem.

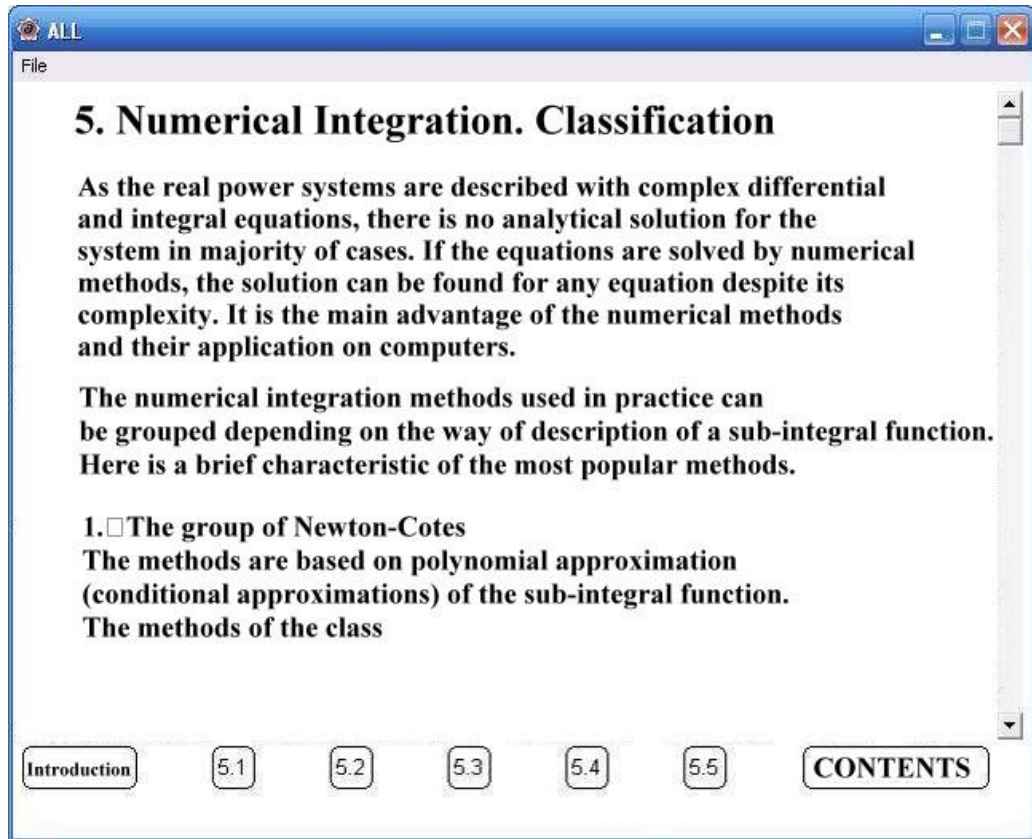

Fig. 6. The working page of the local version of the distance course “Mathematical Methods and Models” created in the system Macromedia Autorware 7.0.1.

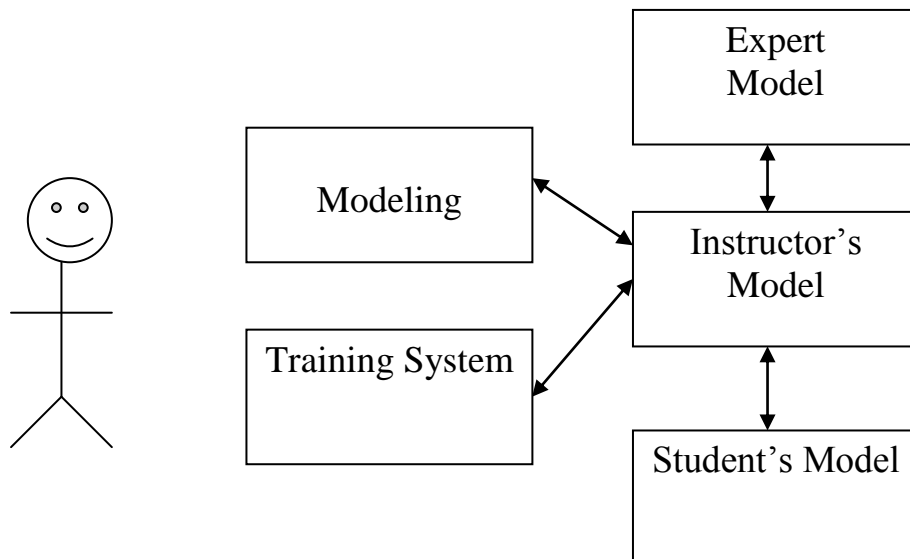

Fig. 7. The training intellectual system components

The paper /23/ shows the scheme of interaction of the AI, pedagogic and software. The scheme of the intellectual training system is given in the fig. 7.

The schematic presentation of education, the AI and software is given in the fig. 8.

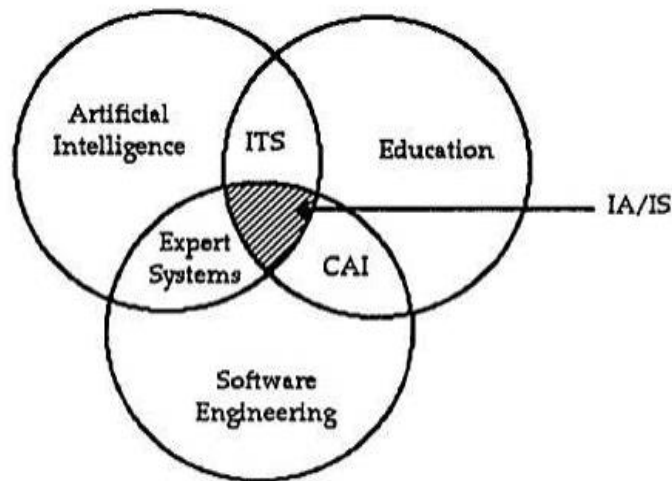

Fig.8. The schematic crossing of the expert systems, information technologies and education.

The operating scheme of the system described in /22/ (see fig.9) is given below.

What are the main spheres of the AI which can be used in our work? According to the work /23/ they are presented in the fig.10.

The Wikipedia emphasizes the following trends in the development of the AI:

- solving of the problems connected with the approximation of the specialized systems of the AI to the abilities of a man and their integration which is implemented by the human nature;

- creating of the artificial intelligence, which is the integration of the created systems into the single system of the AI, and is able to solve human problems.

**Conclusions** The paper shows the place of pedagogic in solving of the main task of the mankind. It might be just a hypothesis for some people. The conclusions won our hearts and we have logic foundations for them.

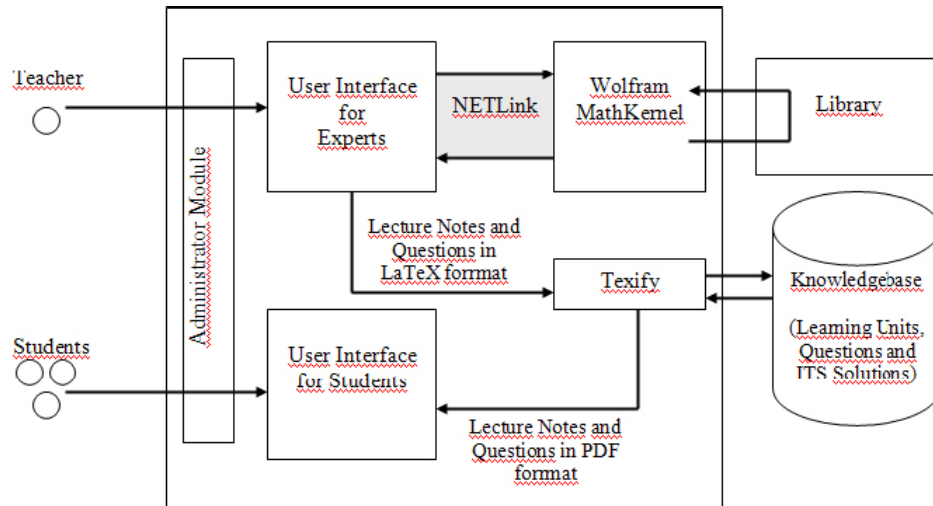

Fig. 9. The general scheme of the architecture of MathITS.

It is our viewpoint on the problem number one stated at the beginning of the paper. The problem number two solving has the following results. The paper shows the spheres of activity of a pedagogue that can be automatized either now or in the nearest future. Our projects which can be found in the Internet are aimed at solving the problems and have not only Ukrainian but also international awards. The ideas stated in the papers are tested and supported by the world community. Follow the links:  
<http://iic.dgtu.donetsk.ua/russian/ovs/ermitaz.jpg>  
<http://iic.dgtu.donetsk.ua/russian/ovs/don.jpg>

As to the particular solution of the two scientific problems we have analyzed three implementations of the distance learning course (based SMS Joomla 1.5, Moodle 1.9.9., and Authorware 7.0.1). The adaptation mechanisms taking into account the peculiarities of students' perception and correcting pedagogic process automatically can not be implemented in the given software yet. We need additional research on pedagogic technologies that can be automatized on the current stage and a new type of the software (similar to Arthur) that can be tested in pedagogic.

The information technologies might not be in demand in the future as they are just a support for the potential human abilities which are not discovered yet. The details are given in our paper /8/.

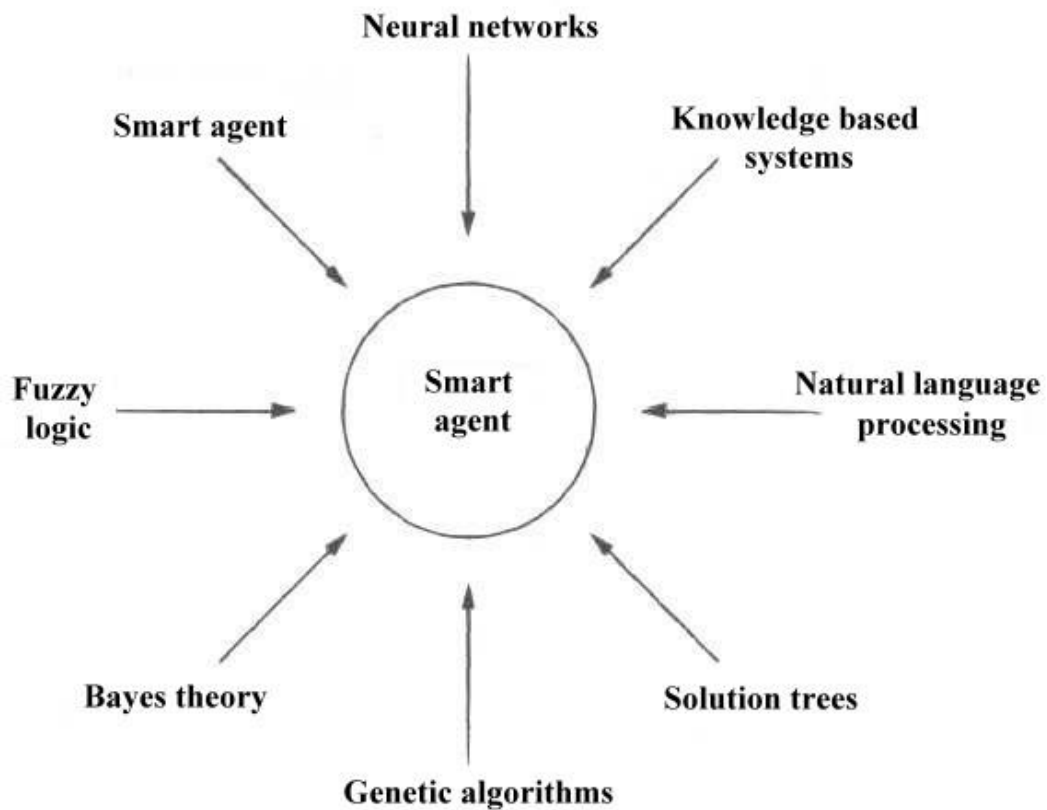

Fig. 10. Main spheres of the AI

References:

1. N.V. Bashkova. About Development of Consciousness (in Philosophical Anthropology and Agni Yoga's Pedagogic) //Delphis №4 (64), 2010. – p. 114-118.
2. Sides of Agni Yoga. – Novosibirsk: Algim, 2010.
3. A.S. Narinyani. Knowledge System and Vastness: Visible and Invisible// The Artificial Intelligence Problems, №2, 2010.
4. K.D. Ushinski. Selected Pedagogic Work Collection in 2 volumes. – M., 1974. v. 1- p. 231.
5. N.V. Bordovskaya, A.A. Rean .Pedagogic. The Tutorial of the New Century. – St.Pb, Moscow, Kharkov, Minsk: Peter, 2000.
6. L. Kroker. Introduction into the Classical and Modern Test Theory. – M.: Logos, 2010.

7. P.V. Stefanenko, S.G. Dzhura, S.A. Isakov. Taking into Account of the Cognitive Thinking Type in the Distance Learning // Proceedings of the XV international scientific and technical conference “Mechanical Engineering and Technosphere in the XXI Century”. Volume 3. – Donetsk: DonNTU, 2008, - p. 175-178.
8. P.V. Stefanenko, A.V. Levshov, S.G. Dzhura. Distance Learning in the Light of Energy and Information Paradigm // Humanitarian Newsletter. Series: Pedagogic Sciences: Proceedings. Issue 1. The Ministry of Education and Science of Ukraine. Cherkassi State Technological University. – Cherkassi: CSTU, 2009. – 114-130.
9. P.V. Stefanenko, S.G. Dzhura, V. I. Chursinov. Peculiarities of the Application of the Artificial Intelligence in the Distance Learning // Proceedings of the XV international scientific and technical conference “Mechanical Engineering and Technosphere in the XXI Century”. Volume 3. – Donetsk: DonNTU, 2010, - p. 122-124.
10. P.V. Stefanenko, S.G. Dzhura, V. I. Chursinov. Peculiarities of the Distance Learning at the Noospheric Development Stage. Proceedings. Series: Pedagogic, Psychology and Sociology. Issue 7 (167) - Donetsk: DonNTU, 2010. p. 33-47.
11. P. Fedoruck. Adaptive System of the Distance Learning and Knowledge Control Based on the Intellectual Internet Technologies. – Prikarpatiski National University Named after V. Stefanik, 2008.
12. The Distance Learning Technologies: Academic Courses Design and Implementation / Edited by M.B. Lebedeva. – StPb: Petersburg, 2010.
13. A.K. Gulyaev. Macromedia Authorware 6.0. Development of Multimedia Training Courses. - StPb: Korona Print, 2011.
14. Gilbert J.E. Arthur: an Intelligent Tutoring System with Adaptive Instruction. Dissertation, submitted to University of Cincinnati. 2000.
15. Karampiperis P., Sampson D. Adaptive Learning Resources Sequencing in Educational Hypermedia Systems. Educational Technology & Society, 8 (4), 2005. - 128-147.
16. Freedman R. What is an Intelligent Tutoring System? Published in Intelligence 11(3): 15–16 (Fall 2000).

17. Gamboa H. Designing intelligent Tutoring System: a Bayesian approach. Escola Superior de Tecnologia de Setúbal, Campo do IPS, Estefanilha, Setúbal Portugal. 2009.
18. Kerner T.J. A tool-supported methodology for authoring intelligent tutoring systems. – Dissertation. Hofstra University. 1992.
19. Al-Muchtadai F. Jalal. An intelligent authentication infrastructure for ubiquitous computing environment. Dissertation. University of Illinois. 2005.
20. Stathacopoulou R., Magoulas G.D., Grigoriadou M. Neural Network-based Fuzzy Modeling of the Student in Intelligent Tutoring Systems. Department of Informatics, University of Athens, TYPA Buildings, GR-15784 Athens, Greece. 2010.
21. Korhan Gugel. Intelligent Tutoring System for education. Izmir, 2006.
22. S. Russel, P. Norwig. The Artificial Intelligence; Modern Approach. – M.: Williams, 2006.

## **Chapter 5. From information paradigm to its syntagma**

### **5.1 Information paradigm- open system theory**

V.V. Otkidach, S.G. Dzhura, A.A. Chursinova

A new paradigm of scientific thinking has been formed in science as a result of the general system theory development and application of the system approach. It can be called integral or ecologically systematic though none of these characteristics reveals its nature. The new paradigm differs greatly from the traditional one the basics of which were formed at the time of R. Descartes, I. Newton and F. Bacon. The following criteria show the difference between the paradigms [1]:

1. The transition from the concept of a “part” to that of “integrity”. The paradigm is founded on the reverse process: the goal of its elements can be understood only on the basis of the integrity as without it the elements can not exist.
2. The transition from the concept of a “structure” to that of a “process”. Every structure in the modern paradigm is understood as

the demonstration of the processes within the system with the networks of interrelations having a dynamic nature.

3. The transition from the “objective science” to the concept of the “epistemological science”. The modern paradigm is based on epistemology and to understand the knowledge forming process we need to be a direct participant of the phenomena under research.
4. The transition from the concept of the “building” to that of the “network” which is the knowledge goal. The knowledge basis is broken within the frameworks of the paradigm change. In the modern paradigm the metaphor of “the building” was replaced by that of “the network”. Today the reality is the network of interrelations and its description is made by the network of interrelations among the phenomena under research.
5. The transition from the concept of “the truth” to that of the “description approximation”. The modern paradigm considers any concept, theory or discovery to be approximate and limited that is the science will never reach the integral and remaining concept of the reality.

The new change of the civilization existence and perception began in the early 60s of the XX century. The sign of the civilization was the intensity of getting and exchange of knowledge and information.

K. Shannon introduced the term of information relative to the code transfer theory in the middle of the XX century. It got the name of the “Information Theory”. The information science started with the theory of transfer and calculation of the qualitative marks of the indefinite concept.

Today the term of information has a profound natural and philosophical content.

All the objects of the Nature consist of elementary particles. That is why the information interactions among the objects are based on the interaction of the elementary particles according to the micro world physics laws.

It is time we examined the concept of the information as the conceptual phenomenon of the global level.

To give the general definition of the information we need the single out its characteristics which

- are the characteristics of any of its presentation;



- allow its distinguishing from other phenomenon presentation.

That is we need to single out the necessary and sufficient characteristics which allow refereing of the phenomenon to the exceptional demonstration of the information concept.

To reveal the necessary and sufficient characteristics we would like to examine the system that consists of the three elements- subsystems: the object, the interaction, the environment.

**The object** is a lasting in time and limited in space formation taken in a number of relations as the integrity – the system element.

**Interaction** is a continuous process connected with the cause-effect relations of transformation of the parameters of the object and the environment.

**Environment** is the arbitrary set of the objects able to influence the object under research and be influenced by it at the certain level of organization.

All natural interactions can be defined as informational ones as all of the interacting objects influence each other (exchange the information). The information might be both material and non-material.

Let us examine the development of the information interaction of the object with the environment depending on the object level in the hierarchy of the substance self-organization.

The information interaction fundamentality is in the fact that any other types of the interaction including the simplest ones (physical) are done only by means of it. In this case the physical interactions in the systems with strong cause-effect relations observe the concervation law: the object gets as much information as it send to tttthe other one. The information loss in the closed environment is impossible.

Any interaction among the objects when one of them sends some substance and the other one gets it is called the information influence and the sent substance is called the information. Two general characteristics of the information being the independent phenomenon are the results of the definition [1]:

- ✓ The information can not exist outside the object interaction that is the information is a process;
- ✓ None of the interaction objects loses the information within the closed system; it is saved in the system format.

It means that the information phenomenon makes the researchers to understand the arbitrary system as the open one and the usage of the concept of the closed system is just a technological method necessary only at the certain stage of the research. The information interaction is the fundamental way of display. The spontaneous environment regardless the substance hierarchy level is the information environment. The information interactions on the elementary level are fully symmetrical. The interactions cause formation of different more stable structures based on the elementary particles. These structures are reasonably to be examined as independent objects.

The object information interaction laws follow from the laws of interaction of their element bases. The more elements the object element bases have and more various they are and the more complex the interaction within the object structure is, the more difficult it is to deduce the laws of the general interaction of their elements. The laws of the information interaction of the objects of a higher level are based on statistic integration of the laws of interaction of their elements that is the objects of a lower level.

The process is the elementary information influence. It is important because:

- this interaction is the simplest complex of symmetrical information influences and can be structuralized easily;
- the interaction displays the main factors which are characteristics of the information influence.

The forms with the help of which the information is sent are called codes. The information perception or imperception is defined by the characteristics of the object which gets the information. The complex of characteristics which allow the object to perceive the obtained information codes is done by the information code interpretation device. Thus to have the information influence there must be codes in the object that transfer the information and the code interpretation device.

The information codes on the wild life level are not simple physical objects and elementary energy influences but their complexes which are more complicated as to their composition and structure. In this case the operation of the information code interpretation devices is based on the complexes of chemical laws which are so complex that it is often

impossible to deduce the clear dependence. Biological laws are shown in this case [1].

Thus there should be some factors for the information code conditional interpretation. One of them is the information control subsystem. The object memory is the basis of the block. The memory is changes which appear in the information code interpretation device as a result of separate acts of the object information influence which are saved for some time after the acts are over.

The object memory is always limited and its major part is invalid. Thus to prevent the memory overrun, malfunction or breakage in its operating there is to be the mechanism of the memory cleansing. The laws of the information transformation have three consequent stages:

- ✓ information code receiving
- ✓ code interpretation
- ✓ implementation of the information that consists of the combination of symmetrical and asymmetrical information interactions with the environment.

The information code carriers are symmetrical information influences in which the receiving objects is the environment element and they do not depend on the receiving object goals. The information codes are always objective. The data taking part in the processes within the object belong to the characteristic that defines the object inner world and is subjective.

Any material system is able to develop as long as its memory allows [2].

The memory exists since the appearance of the self-developing system and during all period of its existence.

It is the memory that is the crucial factor in providing the necessary development preconditions: irreversibility, orientation and law. The absence of the memory is the reason which makes the development process impossible.

Thus gaining of the memory by the system is the obligatory requirement of moving forward. It allows making two main conclusions:

Firstly, the time period within which the system is able to be developed corresponds to its information capacity (the memory); the system is developed depending on the memory capacity for its endless development that is it is to have the memory endless resources.

Secondly, the rate of the system development depends on the ability of it to accumulate, consolidate and reproduce the information and the corresponding process speed.

Gaining of the genetic code by the nature allows the information fixing and it accelerated the evolution rate.

The main stages of the memory system forming are as follows [2]:

**The memory in the inanimate nature** The inanimate nature has the memory that is it is able to accumulate, consolidate and reproduce the information under some certain circumstances. The things can record the information on the influence of other things or natural phenomena made on them. Thus the earth keeps the information on stream canals for a long time; atoms keep the structure of their nuclei unmistakably; molecules memorize chemical element and compound composition. The memory of the inanimated nature is the physical laws which the objects of the micro-and-macro universe observe strictly.

**Genetic memory** forming was quite dramatic. The academician Moiseev [3] assumed that there were several memory structures at the first stages of the life evolution development. The genetic system is more stable and adoptable to the Earth life conditions than others. There is only one system on Earth, only one “alphabet” able to pass all the information necessary to reproduce and support the future generations on the biological species level.

**Ecosystem memory** Neither of biological species is able to exist without the interdependence with other species. Besides its own substance and energy basis any ecosystem has the regulation information system that fixes functions and communication links for the certain biological species. The memory of the majority of the biological species is limited by the genetic code information capacity. The principle qualitative evolution changes in the nature take place at the expense of the ecosystem information mechanisms and natural selection on the individuals' level. Every element of the ecosystem has the memory and it dictates its fixed rules to the system residents. The ecosystem memory plays the crucial role in increasing of the variety of the animate nature on Earth.

**Social memory** is the system of information mechanisms of inheritance and consolidation of the social changes that provide the reproduction of the organizational basics, social relations and the processes of training and

regulation in the social structures. According to the academician N.N. Moiseev it is the memory social form that has played the leading role in the nature evolution since the first human communities appeared [3].

If the social memory, being the genetic one, is the single information system it is to have, as a gene does, the certain carriers and memory units [2].

The XX century made the so-called conclusion as to the nature evolution development. Man plays a crucial role in the process within some moments only; however his role in the nature development acceleration is enormous.

The unprecedented rate of the nature evolution under the Earth circumstances was possible only due to the unique ability of the man to improve the information system of accumulation, consolidation and reproduction of the information. In fact it will be the fourth era in the nature evolution: the inanimate nature – the animate nature- the society – the artificial information systems.

### **References:**

1. A.G. Starish. Systemology. Kiev: The Tutorial Centre, 2005. 232 p.
2. L.G. Melnik. The Development Fundamentals. – Sumy: ITD “The University’s Book”, 2003. – 288 p.
3. N.N. Moiseev. Man and the Noosphere. – M.: Molodaya Gvardia 1990. – 351 p.

## **5.2. Knowledge new paradigm formation**

V.K. Trofimyuk, S.G. Dzhura.

Something which is mystical in one century,  
is the Truth in another one.

Paracelsus

*The paper examines the key aspects of the knowledge paradigm formation on the examples of the latest achievements of genetic*

*engineering and the artificial intelligence (AI) and gives grounds to the vector of their development.*

This process is especially vivid in the advanced spheres of science development which synthesize the scientific schools. These are the artificial intelligence (AI), genetic engineering and modern education system. We carry out our research on the examples taken from the spheres.

**Why do we need the paradigm change?** The answer is clear: there are some factors the explanation of which does not go into the traditional paradigm (R. Kuleshova, N. Tesla, J. Keely, and W. Messing etc). The classification of the phenomena that do not go into the current paradigm is given in the work /1/. It has the classification of the factors that were thought as wonders and which can not be explained within the frameworks of the current paradigm. Aurelius Augustinus Hipponensis (354-430) said: “Wonders do not contradict the nature but our knowledge about it”.

Researchers made the conclusion that scientific theories must be mistaken /2/ long ago. The scientific revolution theory also says it /3/. The current paradigm brakes engineering development. According to the AI the fact that the most important aspects of the intelligence can not be modeled /4/ limits the scientific method. It is also important that there are a lot of varieties of human activity out of reach of the scientific method. They play an important role in conscious interaction of people. They cannot be reproduced on machines /5/. The scientific method is a powerful tool to improve the understanding of a man. However, the approach has a lot of rocks. The author /5/ emphasizes that scientists must not confuse the model with the modeled phenomenon. The model approximates the phenomenon gradually and there always is the **“remainder that can not be explained empirically”**. Researchers have to solve Aristotle’s contradiction between the theory and practice and live between science and art /1/.

The development of the training programmes requires some initial knowledge which has the form of the induced threshold /5/. It is as if the latest knowledge and the ancient one shake hands. The Bible says: “...everybody who has is given, and it is multiplied; the one who does not have has to give even what he has” /6/.

Every computer programme as the reality model and the AI should be thought as an experiment: it puts forward the question and the answer is in the programme result. The reply of the nature on the design and

programme principles forms our understanding of formalism, laws and the essence of thinking and the modern scientific paradigm.

**When will the paradigm (syntagma) be changed?** It is high time we called off limits and moved forward as the new paradigm representatives worked hard and the results were recognized by the traditional science. It concerns N. Tesla first of all and many wonders fixed by different mass media, religions and people from different countries.

We support the opinion of the author of /7/: “Now scientists are split into two groups: those who not reject the experimental results and look for new ways to understand the reality and those who are satisfied with the old ideas despite the fact they do not correspond to the reality. The first are in a minority which is growing and the second are in the majority which is reducing. The new science which does not reject the old one but widens its horizons is based on the broad interpretation of materialism which is fully presented in the concept of Agni Yoga. It gives scientific and philosophical synthesis of all doctrines given to the mankind”.

Researchers working in applied science have left the traditional paradigm and use the terms of the future paradigm. However we think that we can also speak about the syntagma /8/. Let us discuss the most indicative ones.

**“New” terminology for research.**

Everything which is new is known to be the well forgotten old. The concepts which the artificial intelligence operates are taken from the previous centuries and are not permissible for the current traditional paradigm: “essences”, daemons” etc. According to programming engineers for the ordinary mail to be launched on the server the “mail daemon” is to be launched. If we trace the computer engineering history development we will see that the “patterns” of the algebraic interrelations are thought as essences in the descriptions of the first ever programming science (Ada Lovelace and Charles Babbage) /5/. Even one of the modern axioms of the artificial intelligence runs: “Computer programmes are formal syntactic essences”/9/. That is the experts on knowledge engineering have to be modern magicians. Here is one more wonderful example: “Every science chooses its sphere in the universe complex and researches its essences” /10/ and “Cognition is giving different names to different essences, building in

of a new essence to the architecture of knowledge with memorizing of the new image and the future support of the renewed idea of the universe”.

The potential spirituality is one more characteristic of the substance caused by coordination of reasonability and reality of its application in the human existence continuum. The spirituality as the aspiration for the highest point is shown in the real actions, expressed ideas and non-expressed thoughts.

**Obviousness and the reality are to be separated in the new paradigm.**

While doing any calculation (even when we operate numbers) we manipulate with the images which are the form of electrical and magnetic substance.

When the obviousness ruled during many centuries the scientific explanation of the nature and space was coordinated with the religious doctrine and common sense. The radical (but not obvious at all) model that explained the movement of spheres was offered then. Our first ideas about the world were that fundamentally different from their appearances. The gap between the human mind and the environment around it, between the ideas about things and the things themselves is a principle one for the modern theory of intelligence and its organization /5/.

The Sides of Agni Yoga says: “There are two truths: the truth of the dense world, the truth of the obviousness and that of the space, the truth of the reality. Both are rather convincing. It depends upon you which of them to choose. You will live with the truth which you prefer and it will be the only truth for you. The facts and proofs that confirm the correctness of the chosen way are attracted to the focus of the chosen truth. The world outside you is as soft as wax for the spirit: it sees what it wants. The one who wants the light sees the light; the one who wants the darkness sees it. You will be torn between the two until you leave the decrepit man who you are to overcome in yourself. The task is extremely difficult as the decrepit man in the man is lasting. It is him who replaces reality by the obviousness of the dense world and makes consider the visibility the single reality. But he is mortal in you. Face him to death when everything which he lives with and which surrounds him collapses. The truth of the reality looks into the man’s eyes and destroys the world of temporal illusions and shows the impossibility to keep it. The logic of unboundedness differs from that of



Earth. To feel the unsoundness of the earth obviousness it is enough to touch the sphere of the far world with a thought. It can not be denied. The earth obviousness is separate for every consciousness and it exists only within Earth. The truth of the far worlds differs from that of Earth. You may say: there always is only one truth. But the time phenomenon is different for different planets needless to say that about other conditions. One thing is absolute: we should think on the basis of other preconditions- the earth support is over and the surrounding differs greatly from what the consciousness on Earth got used to. We should find the support in something, which is common for all the worlds. And it will be a thought” /11/. The obviousness is called maya. E.I. Roerich wrote: “The maya of all centuries knows when to touch brain. It calls the yarn of fine vibrations from the depth of previous experience and the reality will be coated with the obviousness and cover the grooves of achievements. Colourful maya, it is time we knew you and tell you “Maya, step back” /11/. “You can not fall asleep if you doubt. It will poison the consciousness with its logic and inevitability of the facts of the obviousness. The reality seen by the brain does not reflect the actuality. The obviousness does not show the truth. We are invisible but real and are nothing for the eye that denies us. The fans of the obvious want to make the the Saviour a myth. For the consciousness the reality is what is seen. For some people the world stood on three whales, for others it was flat, for many it was the centre of the universe and the sun and the stars orbited around it. There were a lot of delusions in the people’s consciousness and they will be preserved until the spirit knowledge educates you. Rely on us as we know what you do not, and believe us if you do not want to be the slaves of life and dense obviousness”/12/.

**The acceptance of the idea of God by the coming paradigm.** We agree with the postulate stated in the work /10/: “Unsociability of a researcher in a system does not allow getting absolute knowledge about it. An effort of the mind to leave the system leads someone to the idea of God (supersystem spirit) and others to the cult of their own cognitive position. Wisdom balances close to the bifurcated state.

That is why none of the sciences can cover the entire universe but they form a hierarchy like the knowledge spheres put into one another”.

Here are two main examples of development of the modern science area (when it was formed and at the modern stage). R. Descartes is the central figure in the development of the modern concepts of thinking and mind. In his famous “Meditations” R. Descartes made an effort to find the reality basis by the methods of cognitive introspection only. He rejected the information coming from sense organs as it is unreliable one and had to doubt even the existence of the physical world. He stayed alone with the thought reality and it was in absolute accord with the world outlook of East. He had to prove the existence of himself (I can think and it means that I exist). After he had stated his own existence as a thinking essence, Descartes deduced the existence of God as the Creator and confirmed the reality of the physical universe as the necessary God’s creature /5/.

When sciences and Bible differ it means that the scientists gave wrong interpretation of their own data /13/.

As to genetic engineering, one of the researchers /14/ took part in the discovery of the human genome.

Science is to research the nature and God – the spiritual world in which tools and the scientific language are powerless. The world is to be studied by the heart, mind and soul and the mind is to find the way to cover both spheres that is to make the synthesis which theosophy (the synthesis of science, religion and philosophy) gives us. Agni Yoga and its modern symbol -the trinity sign- rank with theosophy. The moral law makes a theist to look for God that made the universe move and is interested in people and for the theist the synthesis is possible only with taking into account the following argument /14/:

If God exists, he is supernatural.

If he is supernatural, he is not limited by the nature laws.

If he is not limited by the nature laws, there is no reason to think that he is somehow limited by the time.

If he is not limited by the time, he is in the past, present and future and it is the trinity symbol.

It is obscure how the nature could have been able to create itself. There was to be the power which is beyond the time and the space. It might be God.

The subject matter is the synthesis or the harmony between the modern science and belief in God. According to DNA all people are one

family. The DNA is like the computer hard disc which is the means to store information (though there might be system failures and mess in it). RNA is similar to the zip-disc or flash card as it moves together with its programme and is able to produce certain events /14/.

S.M. Zorin compares the new consciousness children with those who have the new generation motherboard /15/. Thus engineering allows us understanding ourselves which is its main world outlook mission from our point of view.

What problems will it solve? We think that these are the problems of image narrowness, importance of physical materialization of thinking processes and the role of culture in the knowledge accumulation and interpretation.

The method used by N. Tesla, J. Keely and others is not understood in the modern science. It concerns the universe ether which was not in demand in the XX century. It is the so called alternative physics. How can the knowledge be taken? Only the spiritual man will not allow the obtained knowledge being used with evil purposes. The statement understood in the today's science appears again: what is good and what is evil? Socrates answered the question: "There is only one good which is knowledge and there is the only evil which is ignorance". Thus the ignorant man is not worth the knowledge and there is only one way to get it which is to be on the next stage of the mankind's development that is to pass from the civilization to spirituality. Everything is accessible only to the spiritual man. The spirituality finding is possible only through culture in its all manifestations.

**Finding of culture or being on the track to the spiritual man.** The transition is shown by N.K. Roerich: "The ignorant man is to be civilized first and then educated, and then sophistication and understanding of synthesis follow which is finished by taking of the concept of culture" /16/. The importance of the transition is in the following words of Roerich: "If you are asked what country you would like to live in and what state system you dream about, you can give the descent answer: "We would like to live in the country of the great culture". The country of the great culture will be your noble slogan. You will know that the country lives in peace which can be present only where the real beauty and knowledge are respected. The military ministers might feel offended but they will have to let the ministers

of education to occupy the first places. Nothing is purer and loftier than the desire to live in the country of the great culture”/17/.

“Is it appropriate to think about culture now?” N.Roerich writes in his “Diary Pages”. “Of course it is. We should think about culture and art in all life times, even in the most difficult ones. We should preserve what the human spirit lives by under all conditions. To keep it we should know the treasure, and to know it we should study” /18/.

E. Roerich writes: “My dear, continue your nice activity according to the circumstances and if it is not expensive. Do not be upset if the results are minor. Who can measure them? The current period is transitional and is full of explosions and it is impossible to carry out planned cultural construction. Let it be the glimmering light as an icon lamp in front of the holy image, as the landmark at the crossroads!” /19/.

There are the following types of people as the structures of the social body /10/:

- 1) the spiritual man with the value system of a high level including the mission and conscious responsibility; the set of the people is the basis of the society, its skeleton; he is not influenced by material and even moral stimuli, his value system is defined genetically, by his own I and is not flexible (that is why he has material losses in his everyday life and is the first to die in catastrophies or survives without any qualitative changes). The people like this are poets, humanists or devotees.
- 2) the material man with the material value system is the flesh and muscle basis of the society; he is influenced by stimuli, especially by material ones; his value system is also genetically based, but the reaction on the environmental impact is very sensitive- he either grows or becomes oppressed to the state of dystrophy; these are businessmen, representatives of uncreative labour and the Philistines.
- 3) the neutral man: the value system is not defined (because of complete devotion to a profession); it is the interim people mass which is irrelevant to 1 and 2; it is a passive part of the society that joins both 1 and 2; however some of the people can be in the field of strong influence at the moments of bifurcation and transform into 1 and 2.

The society consists of all the parts and its entire body is defined by the ration of the parts. The new type of the man – the spiritual and responsible – is to replace the Homo sapiens. It can be done with the help of religion as it states that a man is imperfect and it calls for perfection, critical attitude as to the man's actions and desires. The position is strengthened with understanding of participation of our own body in the common universe and dissemination of the educated man who understands the mankind's mission and is responsible not because of the influence of the religion but because of his own "I".

It is difficult to imagine the world to be completely atheistic but the complete religiosity is impossible either. The countries in which the dialectic of atheism and religion is broken have difficulties in development of all spheres of social activity. That is why the power of the countries with the constitutional organization based on the equality norms avoids the evident commitment to any of the positions as it can cause the impression of inequality of rights in the society /10/.

There was the Institute of Culture at DonNTU 50 years ago and in 2009 it was decided to renew its work. Many years ago there were the reproductions of the paintings from the Hermitage and other world museums on the walls of the university's buildings and lectures on art were delivered. Economics forced culture out because of the civilization development. Then all was burnt in the fire. Now the Institute is going to be revived as it happened to Phoenix. Not every university is brave enough to deal with culture during the years of the world crisis though the time is very important. E. Roerich writes: "Culture is the only reason to improve the life on Earth" /20/. It is possible due to true friends and the international collaboration. We are grateful to all people who helped and are helping to carry the cultural mission which is the main one for the university as research is senseless without culture. Culture shows the development vector and ennobles any activity. N. Roerich translated the word "culture" from Sanskrit as "light worship".

Finding of culture does good to all activity fields – from getting of inspiration to new branches of science. It gives strength to survive in any crisis. Social economics proved that it was impossible to raise the economic level without the rise of the cultural one. "The revived Earth will enter the new era of cooperation, equality and education. The new

construction will be based on knowledge. The new religion of spirit and understanding of psychic energy will be disseminated around the planet. Science will confirm the power of the energy” /19/ It gives the answers to even today’s social and political questions. E. Roerich predicted: “We are close to the end of Armageddon and the world drama will be followed by the period of lull and fast construction in new countries. The star of the World Mother will come up and light our pure Earth with its rays. **All orange fires will be burnt** in the rays and the world of prosperity will be asserted on Earth”. As to entering the NATO: “It was at the new moon period that the mad historical act (establishment of the NATO) was allowed by the ardents. The adoption of the pact filled the atmosphere with hatred and distrust among people. The side became vivid. The events made up the finished pattern and demonstrate the cruel picture of space phenomena and madness of the mankind. The new country will appear on life-saving and will be the best country in every respect” /20/. The new country is known to be revived Russia, Belarus and Ukraine.

A number of events ([http://roerich.com/n\\_m\\_.htm](http://roerich.com/n_m_.htm) ) happened and we would like to show the idea of the organization on the example of one of them. The class “Call of the New Time” was devoted to the 130<sup>th</sup> anniversary of E. Roerich and A. Einstein. The life of the two persons can be the example of genesis and dynamics of the development of modern science and ancient esoteric one which approach each other. A. Einstein offered the classification of systems according to three types of religion development in his work “Religion and Science”. The first stage was composed by heathen beliefs called by Einstein the religions of fear. The second stage was represented by such classical religions as Christianity and Islam. Einstein called them moral religions. The third stage will be the space religion. He was the adept of the last one. It is the Doctrine of Agni Yoga (it is not a religion, but it suits the classification of Einstein). It is one more confirmation that we are on the right track. We speak about knowledge at the classes of the Institute of Culture. Prof. M. Basin wrote: “The knowledge which can be useful to all people can be called the knowledge of the mankind. The main criterion of the criminal nature of the current power is not the number of people killed by it but the amount of free knowledge on which all members of the society were not informed. People who participate in getting and dissemination of the knowledge

necessary for the mankind to survive should have descent existence. We mean the material and information existence of researchers, pedagogues, journalists, culture representatives, religion figures”. /21/ The social assessment is very important to any person as the man can fulfill himself properly only if he gets the corresponding social assessment. The labour in favour of common good is of main importance. A profound reader will find many examples to it. According to the German engineering philosopher H. Lenk the turn in the social consciousness and behavior will give the chance to raise the scale and nature of the voluntary labour and other activity types such as free social labour and give a higher social mark to it. In any case people will measure their social value not only in accordance with their income. There are other types of labour which are not awarded. It might seem Utopian especially in the society that makes money (the American one, for example) but we will have to choose the way and follow it. There are some other highly efficient activity types which are higher than the social reputation based on the ideology of money making which is thought the most prestigious activity of the society members. The future social assessment of the labour, activity and the voluntary work is to take into account the circumstance. Not only the labour and the money have sense and mediate the prestige and dignity. There are other socially intelligent and sense approving activity types /22/.

**Change of the paradigm of universities** IV international conference on higher education “Higher Education: New Problems and the Role in the Development of Man and the Society” held in Barcelona in April 2008 is the example of that the modern education follows the ideas expressed in Agni Yoga.

Higher education priority project Table 1.

<b>TODAY</b> <b>from the individual to competitive</b>	<b>TOMORROW</b> <b>to the social and collective</b>
Focus on the content	Focus on the content, ability and value
Focus on efficient personnel training	Focus on training of professionals-citizens
Orientation on the market	Orientation on the society needs

requirements	
The social application is based on the individual status and enrichment and economic growth	The social application is based on contribution into the team welfare, the society construction and the social development

University uniformity (UU) is not only impossible but is also harmful from the point of view of the mankind's development.

We should be able not only to speak about the future but also to form the future working in coordination and harmony.

**Conclusions:** The general tendency of development of paradigms is quite vivid today if it is seen in dynamics during the last centuries. The modern scientific paradigm combines ancient sciences and their modern representatives such as theosophy and Agni Yoga. That is why engineering philosophy is to be rewritten for the following forecast to become a reality: "The ancient knowledge is to become scientific formulae". It will be the modern paradigm (the syntagma actually). The contours of the paradigm and the main clauses are given in the paper.

#### Reference:

1. M. Talbot. The Holographic Universe. – M.: Sofia, 2004; - <http://www.roerich.com/zip3/talbot.zip> /
2. Popper K.R. The Logic of Scientific Discovery. – London: Hutchinson, 1959.
3. T. Koon. The Structure of Scientific Revolutions. – M.: ACT, 2003.
4. Weizenbaum J. Computer Power and Human Reason. – San Francisco: W.H.Freeman, 1976.
5. D. Luger. The Artificial Intelligence: Strategies and Methods of Complex Problem Solving. –M.: Williams, 2005.
6. Gospel, chapter 25, verse 29. <http://www.bible-center.ru>
7. A. A. Shpunt. Mowgli Children and Energy Heredity Factor// Delphis, № 4(56) 2008. – p.125.
8. A.P. Kovalev, V.V. Otkidach, S.G. Dzhura. Heading to a New Syntagma // Wisdom of Earth Home. About the World Outlook of the XXI Century. Edited by S.G. Dzhura, V.A. Yankina, A.B. Kazanski.



- StPb-Donetsk, 2007 -  
[http://www.roerich.com/zip3/almanach\\_2007.zip](http://www.roerich.com/zip3/almanach_2007.zip)
9. Searle J.R. Is the brain's mind a computer program // Scientific American, 262, p. 26-31.
  10. Y.N. Lachinov. The Universal Tutorial: Cognition Through the Definition of Essences.- M.: KomKniga, 2007.
  11. Sides of Agni Yoga. 1957. – Novosibirsk: Algim Company. 2008.  
[http://www.roerich.com/zip3/grani\\_57.zip](http://www.roerich.com/zip3/grani_57.zip) /
  12. Sides of Agni Yoga. 1958. – Novosibirsk: Algim Company. 2008.  
[http://www.roerich.com/zip3/grani\\_58.zip](http://www.roerich.com/zip3/grani_58.zip) /
  13. Morris H.R. The long War against God. – New York: Master Books, 2000.
  14. F. Kollins. Proof of God: Arguments of a Researcher. – M.: Alpina Non-Fiction, 2008.
  15. S.M. Zorin. The Way to the Light Church. – M.: Publishing House Sh. Almonashvili, 2007.
  16. L. Zasorina. Safety and Education// New Generation: Proceedings №4. – StPb: MANEB MINPI, 2003. – 603 p.
  17. N.K. Roerich. Light State. – Southbury, 1931.  
[http://www.roerich.com/zip/der\\_svet.zip](http://www.roerich.com/zip/der_svet.zip)
  18. N.K. Roerich. Diary Pages (v.1). -  
[http://www.roerich.com/zip/ld\\_1.zip](http://www.roerich.com/zip/ld_1.zip)
  19. Letters of E. Roerich. Volume VIII (1948-1950). - M.: MIIP, 2008.  
[http://www.roerich.com/zip3/ei\\_8.zip](http://www.roerich.com/zip3/ei_8.zip)
  20. E. I. Roerich. Letters. Volume VI (1938-1939). - M.: MIIP, 2006.  
[http://www.roerich.com/zip3/eir\\_6.zip](http://www.roerich.com/zip3/eir_6.zip)
  21. M.A. Basin, I.I. Shilovich. The Way to the Synergonet. – StPb: Norma, 2004. <http://www.roerich.com/zip3/synergonet.zip>
  22. H. Lenk. Mediation about the Modern Engineering.- M.: Aspect Press, 1996; <http://www.roerich.com/zip2/lenk.zip>

### 5.3. Heading to a new syntagma

**A.P. Kovalev, V.V. Otkidach, S.G. Dzhura**

There are three stages of recognition of the scientific truth:  
the first: “It’s absurd”,  
the second: “There is something in it”  
the third: “Everybody knows it”.  
Ernest Rutherford (1871–1937).

The paper analyzes the search and change of paradigms in science and formation of a new syntagma. The analysis is based on the key concepts of physics, mathematics and philosophy on the example of the concept genesis. They hypothesis of the paradigm development and syntagma formation are given.

According to the BSE, “syntagma” means “joint”, “built together”. The Brockhaus and Efron Encyclopedic Dictionary says it is the name of the work that gives systematic review of the subject matter of one scientific or practical sphere.

**The problem topicality and historical aspect** The famous American researcher T. Kuhn examined the dynamic of the paradigm change from the classical point of view /1/. His works and those of I. Lakatos are so topical that we have all reasons to suppose that another paradigm will be changed. More than that, the fact of existence of man on Earth will depend on the correct choice of the development direction. The academician V. A. Zubakov said at the event called “Days of St. Petersburg’s Philosophy” that we need not only to change the paradigm but also to find a new syntagma. The positions of all sciences and methodological approaches known to the mankind are of great importance in order to attract all forces and find the way out of the system crisis. The traditional science and the esoteric one have different methodological approaches but drive to one and the same conclusion on modern problems (the mankind’s system crisis in particular). Besides, the development and genesis of the concept of esotericism as a science is in the viewpoint of the paradigm change. Further on we will give a number of arguments in favour of it being the new syntagma of the mankind. We should say that the

concept of esotericism is though negatively by the scientific community because of the information permissiveness that appeared after the USSR collapsed and the current irresponsible publications. However, it does not influence the hidden meaning of the word “esotericism”. Many researchers of the tradition are trying to find the meaning. Many of them got the results which nobody is able to repeat now. We mean the mystic discoveries in the field of power engineering made by the Serbian inventor N. Tesla. Many books, papers and films are devoted to him, but the traditional science is unable to understand how everything he did operates and how he could invent his unique devices without a computer and modeling which modern engineers got used to. Besides, he applied the so called neoclassical physics in which there is the place for the universe ether. It was the esoteric approach that worked and is working! All Tesla’s inventions are optimal (that is optimization tasks were solved by neoclassical method). E. Blavatskaya, who is an authoritative follower of the ethic and philosophical gnosis, wrote in terms of esotericism that “the fact that false money is somewhere proves that the real one is somewhere too”. We understand that it is not a strict mathematical proof (it is an inductive method), but the basic theorems of medieval mathematics can not be proved without the induction.

**Genesis and tradition of the paradigm change.** The positions of Kuhn and Lakatos have a number of common characteristics such as principal theoretical loading of empiric factors, a desire to be based on the history of science as the methodology empiric foundation, focusing on the development of scientific knowledge which is understood as not just accumulation of facts and theories but the sequence of cardinal changes of science and standards and ideals of the scientific rationality, refusal from strict demarcation lines between the science and not science, recognition of the important role of metatheoretical and social and cultural factors when the prevailing scientific concepts are replaced by new ones /1/.

V. Kuznetsov widened the frameworks of the science development vector in his preface to the new edition of the research of T. Kuhn “Postpositivism is finished by the concept of methodological anarchism of P. Feyerabend who stated the shocking principle “everything will do” in the book devoted to Lakatos “Against the ...Method” (1975). It was based on his idea that the knowledge growth is caused by theory and approach

multiplication that is why it is necessary to support the position of the consequent pluralism in science and beyond it and welcome appearance, dissemination and interaction of different sometimes crazy and exotic ideas. The science is understood as an anarchic body and does not differ from other social and cultural traditions and practices and thus has no privileges. That is why the science is to be separated from church; the state is not to give it an exceptional support, but is to give it opportunities equal to those it gives to a religion, a myth and magic.” /2/ Thus many elements of esotericism which thought to be non-scientific fit to the modern world outlook and are to be introduced into the scientific circulation.

**Esoteric approach hypothesis.** We think there is to be a balance between the new and the old. If to give preferences to the old there will be no new at all, and if to give the preferences to the new, it will get you too far. That is why the new is to be analyzed critically in the light of the old. The brain storm method applied at the first stage of scientific problem solving is based on the rule: any idea even the most exotic one is to be advanced. Then a complete list of the ideas is to be made up and only then they are to be analyzed critically. The genesis of the concept is given in the epigraph to the paper. The first edition has a paper of Prof. Ableev “About the World Scientific Picture” /3/. The editor of the book was quite critical as to the paper. It was the first stage in understanding which Rutherford called “absurd”. We would like to show that the approach has a sense and we will use Kuhn’s theory of scientific revolutions (in which the word “esoteric” has a positive context). The approach is the very syntagma we are going to talk about. The second edition of the work collection is to mark the next stage of understanding which is, according to Rutherford, “there is something in it”. At least new scientific tendencies can be taken as a hypothesis.

**Paradigm change inevitability.** According to T. Kuhn the paradigm (a disciplinary matrix) is a set of knowledge, methods and values that all members of the society take unconditionally. He singles out the following stages of its development: pre-paradigm science, normal (paradigm) science and extraordinary science (the scientific revolution which is beyond the paradigm). The pre-paradigm science is an eclectic combination of different alternative hypotheses and competitive scientific communities with each of them creating their own models without any special appeal to

external authorities. However, some theory moves forward in the course of time and it is interpreted as a pattern of problem solving and is the theoretical and methodological foundation of the new paradigm science. The paradigm defines the range of significant scientific problems and possible ways of its solving and ignores the facts and theories that do not agree with it. The progress is made through the cumulative accumulation of knowledge, theoretical and practical improvement of initial programming directives in the frameworks of the normal science. However, scientists come across a number of anomalous facts (that is those which are not articulated adequately in the frameworks of the accepted paradigm) which lead to scientific crises related to the extraordinary science after numerous unsuccessful efforts to explicate them by the traditional method. The situation reproduces the pre-paradigm state of the scientific knowledge as, besides the old paradigm, many alternative hypotheses giving different interpretation of scientific anomalies are developed. Further on the theory which, according to the professional community of scientists, offers the most favourable version of solving of scientific puzzles. The priority of any of scientific theory is not automatically provided by its cognitive advantages and depends on a number of extra scientific factors (psychological, political, cultural etc.). The convention reached on choosing of the model theory means forming of the new paradigm and marks the beginning of the next stage of the normal science which is characterized by the clear programme of activity and artificial selection of the alternative and anomalous senses. The knowledge which was obtained by the preceding science history is not an exception /1/.

The visibility of cumulative succession in the knowledge development is caused by the process of special education and tutorials that interpret the science history in accordance with the directives given by the ruling paradigm. That is why it is quite a problem to speak about the real progress in natural science history. Improving of the knowledge characterizes only the periods of the normal science which form the unique understanding of the world having no special advantages compared with the rest ones /1/.

T. Kuhn writes: "Similar problems and orientation combined the majority in accordance with the benefits of historical and other research

which seem different at first and which I published after my internship in Harvard. Some of my works dealt with the important role different metaphysical ideas play in creative research”. /1/ Metaphysics which is a basis of esotericism plays a significant role in research and inspires and gives ideas for its implementation. Life is more difficult than schemes and it has much of what our wise men haven't even dreamt about. Didn't N. Tesla mean the paradoxes?

When T.Kuhn speaks about the paradigms he implies the recognized scientific achievements which give the model of problem setting and solving to the scientific community in the course of time. But the model can not cover everything, including N. Tesla's phenomena, ether machines of J. Keely or turbine engines of V. Schauburger etc.

**The golden ratio as a confidence interval** We think that the traditional science (the normal one according to T. Kuhn) is to be in golden ratio with novelties. It is a prototype of the confidence interval which is used to cut off unreliable data in engineering. The normal science often suppresses fundamental novelties because they destroy its main directives. However the normal research guarantees that the novelties will not be suppressed too long as long as the directives have the element of randomness. Sometimes the normal science problem which is to be solved with the help of famous rules and procedures resists the pressure of the most talented team members to the competence of which it belongs. In other cases the tool aimed at being used for the normal research is unable to function in the expected way, and it demonstrates the anomaly which can not be coordinated with the norms of professional education despite all efforts. Thus, the normal science always loses its way. When it happens the specialist can not avoid the anomalies that destroy the corresponding tradition of the scientific practice and the non-traditional research starts. It leads the science branch to the new system of orders, to the new basis for the research in the long run. T. Kuhn considers the extreme situations in which the change of the professional orders occurs as the scientific revolutions. They are additional to the traditional activity in the period of the normal science and destroy the traditions/1/.

**Esoteric stage as a sign of the scientific theory maturity.** T. Kuhn is sure: “Forming of the paradigm and appearance of more esoteric research based on it is the sign of maturity of development of any scientific

discipline”/1/. We should do justice to the fact that what the ordinary consciousness thinks about esotericism and what the yellow press that forms rather mixed public opinion writes about it does not reflect the reality. We support the idea that the field development is to be done by scientific methods and have the integral system of analysis and synthesis which a number of Internet projects, scientific conferences and seminars and associations are trying to do now. The operation of the international non-governmental association “Ethics and the Future Science” (<http://ethics.roerich.com/>) is a bright example of the creativity. Its founders are Moscow Higher Technical Institution named after N.Bauman, the Institute of Oriental Studies, the Institute of Mathematics named after M. Keldysh, Donetsk National Technical University and others (<http://roerich.com/delfis/index.html>). A number of dissertations on heritage of the great family of the Roerichs who are the recognized authorities in ethic and philosophical gnosis were defended. The conferences and the dissertations emphasize the place E.Roerich and N. Roerich occupy in the world philosophy and culture. The set of dissertations on the subject matter is given on <http://aipe.roerich.com/russian/ims/diser.html> and it includes the doctoral dissertation of S. Ableev.

T. Kuhn is sure that the research forms a fund of factors a part of which is accessible to the simple observance and experiment, and others are more esoteric and taken from such spheres as medicine, metallurgy and calendar making up. In other words, they drove to the paradigm which is able to direct the research of all the team in general. It is difficult to find another criterion (if not to take into account the advantages of the retrospective view) which can give the direct support to the idea that the knowledge branch has become science.

What is the nature of the more professional and esoteric research which is possible after the integral paradigm is accepted by the team of researchers? If the paradigm is the work which has been done once and for everybody which problems does she leave for the group to solve? Some terms used by Kuhn might lead to misunderstanding and thus the answers to the questions are to be found urgently. The concept of the paradigm means an accepted model or pattern. This aspect of the meaning allows T. Kuhn using it. But the meaning of the words a “model” and a “pattern” that

implies correspondence to the object does not cover the definition of the paradigm in full.

The majority of researchers introduce proper order corresponding to the certain model. It is the normal science according to T. Kuhn. When the activity is examined in the historical context or in the modern laboratory there is an impression as if the nature is being crammed into the paradigm as if the latter is a built beforehand and rather tight box. The goal of the normal science is not to predict the phenomenon new types. The phenomena for which there is no room in the box are often not taken into account. The scientists representing the normal science do not create new theories and are intolerant to the creation of them by other colleagues. /4/

T. Kuhn asserts that the paradigm concentrates attention on a small area of esoteric problems and makes the researchers investigate some fragment of the nature in detail which would be inconceivable under other circumstances. The normal science has its own mechanism which weakens the limitations which appear during the research when the paradigm becomes inefficient. Then the researchers change their tactics. The nature of the problems under the research is also changed. While the paradigm is functioning successfully the professional community solves the problems which they would never be able to solve without the paradigm. At least a part of the achievements is always valid /1/.

There are rules which all researchers –professional are following now. However the rules are unable to cover everything which the normal research types have in common. The normal science is the deterministic activity of the high degree but there is no need in it being determined by the certain rules. That is why T. Kuhn preferred the principle of the conventional paradigm rather than conventional rules, points of view and assumptions as the source of coordination in the traditions of the normal research. The rules, according to him, follow from the paradigms but the paradigms can control the research even when there is no rules /1/.

**Importance of crises for methodology.** Failure in solving of new problems often disappoints but never surprises. Neither of problems and puzzles is solved at once. All the examples emphasize the important role of crises: the crises were solved partially during the period when there was no crisis in the corresponding science and therefore the forecast was ignored.



The importance of the crises is in the fact that they demonstrate the timeliness of change of the research tools.

The people who are successful in fundamental development of the new paradigm were either too young or newcomers in the field the paradigm of which they were developing. The concept might not need explanation.

Thus there is to be a conflict between the paradigm which discovers the anomaly and the paradigm which makes the anomaly regular later.

According to T. Kuhn the paradigms can not be corrected in the frameworks of the normal science. The normal science leads to understanding of the anomalies and the crises in the long run.

**Strange role of textbooks.** The knowledge about science which both amateurs and specialists have is based on textbooks. However, the textbooks as pedagogic means are to be rewritten as a whole and partially any time when the language, the problem structure and the normal science standards are changed after every scientific revolution. As soon as the textbooks are redrawn the role and existence of the revolution due to which they came out are masked. If the man himself did not feel the revolutionary change of the scientific knowledge, his understanding of the scientific literature applies only to the result of the latest revolution which was developed in the discipline /1/.

Thus, according to Kuhn, the textbooks narrow the feeling of the discipline history and replace the formed vacuum by a surrogate. The scientific textbooks include only a small part of history which is either in a preface or, which is more often, in references about great personalities of the previous centuries which are scattered throughout the text. The references let students and professionals feel participating in history. However the historical tradition which is taken from the textbooks has never existed. The textbooks and the majority of papers on science history refer to only that part of papers of the researchers of the past which can be easily taken as the contribution into solving of the problems corresponding to the paradigm accepted in the given textbook. Partially because of the material selection and partially because of its misrepresentation the researchers of the past are shown as the scholars who were working at the constant problems to which the latest revolution in the scientific theory and method gave the prerogative of the scientific nature. It is not a surprise that

as soon as they are rewritten the science gets the external signs of a cumulative one.

Suppressing the changes and attempting to give the linear presentation of the science the textbook hides the process which is the background of the majority of significant events in the development of the science.

As far as researchers are sensible people the certain argument can convince them. But there is no argument which can or must convince all. It is a significant shift in distribution of professional inclinations but not in making of the entire scientific community change the mind.

What for is a physics student to read the works of Newton, Faraday, Einstein or Schrödinger when the concept given in their papers is in the modern textbooks in a brief and more systematic form?

The researcher drives to the conclusion that the science is developed on the way to the modern peak. He thinks the history of his science to be progress. He has no other alternative as long as he is in the frameworks of his sphere.

T. Kuhn says that a member of the mature scientific community will look like the character of G. Orwell's book "The Year of 1984" who is a victim of the history rewritten by the authorities. More than that, this idea is not ridiculous at all. The scientific revolutions have both losses and findings, but the scientists are inclined not to see the former ones /1/.

According to T. Kuhn the textbooks are the results of the scientific revolution. They form the basis for the new tradition of the normal science. When their structure was discussed one moment was omitted. What is the process with the help of which the new aspirant to the status of the paradigm replaces the predecessor? Any new interpretation of the nature, be it a discovery or a theory, appears in the head of one or some individuals. These are the people who learn to see the science and the world in a different way and their ability to transfer to the new view is made easier by two circumstances which the majority of the members of the professional group do not share. They concentrate their attention on the problems that cause the crisis; besides, they are so young or just newcomers in the field covered by the crisis that they are less connected with the world outlooks and rules which are defined by the old paradigm than their contemporaries are /1/.

This situation is illustrated by a Zen **parable about a cup of tea**.

Nam In, a Japanese Zen master, received a university professor who wanted to ask questions about Zen. Nam In poured a full cup of tea for the professor and continued doing it. The professor watched it and then exclaimed:

- The cup is full! There is no room in it!
  - You are full with your opinions as the cup is full of tea, Nam In answered. –How can I show you Zen before you empty your cup? /5/

**The point of view of the young or law of denial of denial**

Whithead got the non-historical spirit of the scientific community and wrote: “The science which does not decide to forget its founders is dead”. But T. Kuhn thinks he was not just that right as the science needs its Heros and saves their names. Fortunately, the scientists have always a chance to forget (or reconsider) their works, not their names. Thus, due to the textbooks we know Newton as a great physicist and mathematician. Newton was quite critical as to his own works but he thought his “Interpretation of the book of Prophet Daniel” to be his main work. His epitaph reads: “He glorified the powerful Creator in his doctrine. He proved the required simplicity of Gospel by his life. Let the mortals be happy that such a decoration of the human species lived among them” - <http://www.alhimik.ru/great/newton.html>. Another great physician A. Einstein always had a book of E. Blavatskaya “The Secret Doctrine” (the fundamental philosophical work on the synthesis of science, religion and philosophy) on his desk. “Einstein’s niece visited the head quarter of the theosophical community in Adayar during her stay in India in 1960. She explained that she knew nothing about theosophy and the community but had decided to visit it as she had seen the book of Blavatskaya “The Secret Doctrine” on her uncle’s desk <...>. Jack Brown also wrote about the fact in his paper “Being a Guest of Prof. Einstein” /6, 7/.

C. Darwin wrote in his book “On the Origin of Species”: “Although I am sure in the truth of the outlooks which are in the book in the form of a short review, I am not going to convince experienced naturalists the brains of whom are full of factors examined by them during many years in the point of view which is opposite to mine. But I trust in the future and the young generation of naturalists which will be able to weigh up both sides of

the problem” /8/. Max Plank described his career in “Scientific Autobiography” and remarked that “the new scientific truth shows the way to the triumph not with the help of convincing of the opponents and making them see the world in the new light, but because the opponents die sooner or later and the new generation which got used to it grow” /9/.

Although some researchers, especially not young and more experienced ones, can resist as long as they would like to, the majority of the researchers transfer to the new paradigm. Conversion to a new faith continues until there is not a single supporter of the old paradigm alive and the entire professional team is guided by a different paradigm /10/.

**The role of the mathematical faith** It is a very interesting fact that while talking to mathematicians you can hear the phrase: “First I understood that the theorem is correct, and then I proved it”. The proof of the axiom leads to a deadlock – it can not be proved! That is it is correct, we understand it, but we can not prove it. Thus we take the axiom on trust. The axiom itself is the basis for mathematical proofs. T. Kuhn thinks that those who accept the paradigm at an early stage have to make a step and ignore the proof that is guaranteed by the problem solving. In other words, they are to believe that the new paradigm will be successful in solving of a wide range of problems which it meets knowing that the old paradigm failed in solving of some of them.

The solution is to be based on belief only. This is one of the reasons for the previous crisis to be so important. The researchers who did not survive the crisis reject the evidence in solving problems in favour of something which is considered imperceptible. But just the crisis itself is not enough” /1/.

The scientific community is an extremely efficient tool for the maximal growth of the problems which are solved because of the paradigm change and the accuracy of their solving.

As far as the solved problem is the scale unit of the research achievements and the team knows very well which of the problems have been already solved, very few researchers will easily accept the point of view which casts doubt on many problems solved before. The nature is to undermine the professional confidence and show weak points of the previous achievements. Besides, even when it happens and a new aspirant for the paradigm appears the researchers will resist it until they are sure that

two main requirements are met. First, the new aspirant must solve some disputable and conscious problem which can not be solved by other method. Secondly, the new paradigm must promise to save the real ability of the problem solving which the previous paradigms have accumulated. The novelty in the sake of novelty is not the goal of science as it might be in other creative areas.

What are the problems which the esoteric approach helps solve? First is axiological which means the search of the purpose of life. The President of the USA John Kennedy said the phrase when there was the Caribbean crisis: “I have thousands of specialists who can build a pyramid but none of them who can tell me whether it is worth building”. The popular phrase emphasizes that the world needs system analysts and wise people who are able to see the entire problem but not just an aspect. The modern science needs the people to define the stable trajectory of the human civilization development. E. Roerich says: “The mankind can’t be transformed into **the civilization robots** as it won’t last several centuries in this case. The life highest centres will be calm and the best abilities to make progress in our inner essence will die. We are to be aware that nothing can exist without roots and foundations and thus the foundations of culture and humanism are to be preserved in any country first of all if the country wants to live and flourish. So the fate of many countries and may be the existence of the entire planet is in the hands of the mankind” /11/.

The second is solving of the problems that have been accumulated and not solved within the frameworks of the old paradigm: the phenomena of Rosa Kuleshova, N.Tesla etc. The phenomena are easily explained by the esoteric approach about which the Sides of Agni Yoga reads: “Ancient knowledge is to be transformed into scientific formulae”.

**Fundamental and new approach to knowledge** T. Kuhn wrote: “We do not have the direct access to what we know and the rules or generalization in which the knowledge can be expressed” /1/. The esoteric approach gets the knowledge by other method. It is a surprise that famous pillars of science did not have any degree (that is they got their knowledge by esoteric method). These are K. Tsiolkovski, and the famous foreteller of the last century E. Cayce. The shoemaker J. Bohme, the illiterate engraver W. Blake, non-educated prophets Ezekiel and St. John the Theologian with

his terrible Apocalypse had such insights /12/. Isn't it the Apocalypse that is in the gateway of the mankind now?

Here we speak about one of the main and the most diverse phenomenon of a religious, occult and mystic life. It is the phenomenon of man's perception of different types of information (messages, recommendations, and directions) which comes from an invisible source and is taken by the man differently – from his own sub consciousness or the highest “I” to bodiless spirits (dark and light) and gods including the Creator and Pantocrator. Thus the phenomenon is interpreted according to the man's world outlook and abilities combined with the contact nature and the content of the obtained revelations /13/. Prof. Puck called the source “the space data base” or God /14/. It is true that little knowledge leads away from God and much knowledge leads to it. The words of G. Weyl, a famous mathematician, about the researchers that got the peak in torments and were surprised to see theologians sitting there in comfort are distinctive.

**The balance of faith and knowledge** The accuracy of the forecast especially of the quantitative one, the balance between the esoteric and common research subjects, the number of the problems which the theory helped solve are the most fruitful criteria of the research.

The knowledge is something which is proven by the intelligence or feelings. Wisdom and mind purity required abstaining from the statements that are not proved; the gap between abstract discourse and the real knowledge is to be reduced to zero. Are the intelligence and feelings capable of proving the knowledge? The sceptics doubted it more than two thousand years ago. However scepticism had to retreat in the face of Newton's physics. Einstein put everything upside down and now only a few philosophers and researchers still believe that the scientific knowledge is proven or at least can be /15/.

**Conclusions** Oriental metaphysics is consonant with new scientific tendencies. The concept of esotericism is to be introduced into the modern natural science. The esoteric science is to be studied as thoroughly as the traditional one. The most topical problems of nowadays can be solved by the approaches that the ethic and philosophical gnosis illustrates. The combination of the present scientific view on the world with the esoteric one will give the mankind a new syntagma and the possibility to survive.

We would like to finish the paper by the words of our most famous countrywoman E. Blavatskaya about the future of the science: “The future opens the most grandiose outlooks to us. It is the time for the cyclic coming back to the mystic thinking. We are surrounded by the ocean of the universal science – the science about the eternal life that has the sunken treasures of the past generations” /16/

#### References:

1. T. Kuhn. The Scientific Revolution Structure. M.: AST, 2003.
2. V. Kuznetsov. To Understand Science in the Cultural Context// T. Kuhn. The Scientific Revolution Structure. M.: AST, 2003.
3. S.R. Ableev. About the World New Scientific Picture// Wisdom of the Earth Home. About the World Outlook of the XXI Century. Ecogeosophical Literary Miscellany, issue 4-5 edited by V.A. Zubakov. St.Pb- Donetsk, 2003; - <http://www.roerich.com/zip2/almanah.zip>
4. E.V. Khomichev. History of Philosophy// Mn: Interpressservice; Knizni Dom, 2002.
5. Parables of the Mankind (all famous traditions).Draftsman V.V. Lavski. – Mn.: Lotats, 2001. – 608 p. <http://www.roerich.com/zip/pritchi.zip>
6. S. Krenston, K. Williams. E. Blavatskaya: Life and Work of the Founder of the Modern Theosophical Movement. Riga-Moscow: LIGATMA, 1996.
7. S.G. Melnikov. Vsevolod Solovyov and Vladimir Solovyov about Blavatskaya and Theosophy// Adamant, №3, 2006. – <http://lomonosov.org>
8. C. Darwin. On the Origin of Species by Means of Natural Selection, or the Preservation of Favoured Races in the Struggle for Life. – StPb.: Nauka, 1991.
9. Plank M. Scientific Autobiography and Other Papers. – N.Y., 1949.
10. B. Barber. Resistance by Scientists to Scientific Discovery. – "Science", CXXXIV, 1961, p. 596-602.
11. E.I. Roerich. Letters to America. V. 3. – M.: Sphera, 1996. [http://www.roerich.com/zip/fosdik\\_3.zip](http://www.roerich.com/zip/fosdik_3.zip)

12. L.N. Melnikov. The Virtual Reality and the Space Consciousness // Delphis, №2 (46), 2006.  
[http://roerich.com/delfis/delphis\\_2006\\_2\(46\).djvu](http://roerich.com/delfis/delphis_2006_2(46).djvu)
13. D. N. Popov. Urusvati // E.I. Roerich. Letters to America. In 3 volumes (1929-1955). V. 1. – M.: Sphera, 1996.
14. V.V. Puck. Engineer, Mathematics and Others: Simple Methods of Mathematical Modeling of Natural and Anthropogenic Processes/ Donetsk State Technical University. – Donetsk, 1995. – 224 p.
15. I. Lakatos. Falsification and Methodology of Research Programs // T. Kuhn. The Scientific Revolution Structure. M.: AST, 2003.
16. E. P. Blavatskaya. The Different Side of Life. – M.: Sphera, 2005.

## **Chapter 6. Ethic Algorithms of the Universe**

### **6.1. Ethic Algorithms of the Universe**

A.V. Levshov, S.G. Dzhura, V.I. Chursinov

*The genesis of forming of the universe algorithms from the evolution ones to ethic is analyzed. The hypothesis of a new approach to the distance learning based on the ethic algorithms is offered.*

**Introduction** The mankind has entered the knowledge epoch /1/. The cost of the knowledge is higher and that of material resources is lower. Thus the modern company costs about 90% and it is what it knows or what belongs to it in the form of the knowledge and skills. Algorithms evolve with the knowledge.

**Accumulation of the badly learnt knowledge** Every year knowledge increases twice. Was it the Internet great Plato was talking about: “Absolute ignorance is not the greatest evil: accumulation of the badly learnt knowledge is worse”. If we did not sleep and eat, and could read at a huge speed, we would not be able to read all books published in the world. What shall we do? We should develop the strategy which will answer the question: What should we know to know all the rest? What is the most important thing in the world? What should we do not to waste our life on minor things?



**Life strategy** The mankind has developed different strategies. They are in different philosophical systems, religions, scientific schools etc. How should we behave in the informational era? What for should we accumulate unnecessary knowledge? The most of the strategies are concentrated in the algorithms to gain success in the informational age. Let us analyze them.

**Algorithm genesis; Evolution modeling as a form of the world cognition** The function of learning (adaptation) was singled out in the artificial intellect. It helped to develop connectionist (neuron networks) and evolution (genetic algorithms) models. The paper [2] offers the following classification of the evolution models on which the evolution algorithms are based:

- ***C. Darwin's evolution model*** it is the process with the help of which individuals of some population having higher functional significance (with strong characteristics) get better chance to reproduce the posterity compared to "weak" individuals. This mechanism is often called the method of "survival of the strongest";
- ***Lamarckism or the evolution model of J. Lamarck.*** He proposed a theory based on supposition that the characteristics got by the individual (organism) during his life are inherited by the descendants. Unlike a simple genetic algorithm this model turns to be the most efficient one when the population gathers in the field of local optimum;
- ***Saltationism (evolution model of de Frieze).*** This model is based on the modeling of social and geographical catastrophes which lead to a sharp change of the species and populations. Thus, the evolution is a succession of sudden changes in the development of the population without preliminary accumulation of quantitative changes in the evolution process;
- ***Model of K. Popper.*** He considered the evolution to be the developing hierarchic system of flexible control mechanisms in which mutation is interpreted as the random trial and error method, and selection- as one of the control ways correcting of the errors when interacting with the environment;
- ***The evolution synthetic theory*** was described by N. Dubinin (an attempt to integrate different evolution models, including those of C. Darwin, J. Lamarck, and de Frieze). Recognition of stochasticity of mutation process and great reserves of recombinant variability is its cardinal proposition. The conditions of the environment are the factors which not only exclude the unpractical from the population, but also form the characteristics of the evolution synthetic theory itself.

The evolution of the engineering systems is the process of constant optimization of biological species in which the natural selection is the main

directing force [14].

The evolution theory has influenced the people's world outlook since its appearance. The theory presented by Charles Darwin in his work "Origin of Species" in 1859 started the changes. But Darwin, as well as many of his contemporaries, assumed that the development was based on the natural selection and could not prove many sufficient concepts of his hypothesis. For example, he was not convincing enough to show how the inheritance mechanism should work to support the necessary level of variability. The idea, however, turned to be rather fruitful.

So, it is not a surprise that the scientists dealing with the computer investigations turned to the evolution theory in their search for new solutions and inspiration. The idea of the computer system with the simple mechanisms of variability and selection functioning according to the evolution laws in the nature systems was rather attractive. This hope caused a number of computing algorithms and systems built on the principles of the natural selection and genetic inheritance.

The history of the evolution computations started with the development of a number of different independent models of the evolution process. There are three main paradigms among them [15]:

- ◆ Genetic algorithms (GA);
- ◆ Evolution programming;
- ◆ Evolution strategies

**Evolution algorithms as the Evolution Laws in esotericism ( laws of Dharmah, Hierarchy, Karma etc.)** This topic was dealt with many times with different level of completeness (see, for example, [4-6]). Here we can't help citing Elena Roerich: "There are a lot of the stopping, but they are unable to stop the "World's Karma flow." The confidence in the righteousness of the construction of the New, in the world's evolution came strongly and passionately into the consciousness of young generations. In fact the fight between the Light and Darkness is taking place. It is the fight for the Light, Common Good, for revealing of the real Knowledge and approval of the Beauty" [7].

«The events wil happen unexpectedly, but they will always be in favour of our country. The awful time will spread quickly aspurifying vortex. The problem is that many people do not understand the reason and meaning of the events taking place in the entire planet. New consciousness must love the waveof new construction. The new construction must liberate thinking therefore causing good changes. The evil accummulated in the world will be settled by perturbations. But do not be afraid! There is a shield of the Light over the new consciousness which has refused of evil and envy and understood where the evolution flow was rushing. The evil

spread will be stopped. The Space Justice will activate new leverages and the world's new karma will start asserting itself" [8].

People are eager to blame the Teachers in resorting to human's injustice while preparing the New World. But let accusers reach the Space Consciousness at least once and reckon with the Space Terms. All the key moment of themankind's evolution are related to the latters. The Teachers while getting the consciousness of the New World ready think of number of people with new Space Consciousness necessary for the Space Balance being gathered in a certain place of the Earth.

The world's politics and economy have never been and will not be the decisive moments of the evolution. The aim of the eveolution is to create not a person who thinks politically correctly, but the person who is able to think by the Space categories. Politics, economy and all social formations created by them teach a person to know the matter only on smaller and temporary examples. It would be ridiculous to think that "justice" or "unjustice" of these short forms of the person's social life are the measures peculiar to the Space Intellect. Even the karma of some people and the nation's Karma are such different values that they can not be compared. Sovereigns direct people's fates and, as an exception, watch the karma of some of them. If Ivanov had killed Petrov, and Petrov revanged by killing Ivanov, they will go on killing each other until one of them renders good for evil and breaks the magic circle. The seeds of the good are to be grown and gathered, while the world's evolution ideas, like magnets, are spread in certain parts of the world according to the evolution Space plan. Incarnation of the people able to catch the ideas takes place in these world's parts [9].

**From evolution algorithms to the ethic ones.** The idea of Ethic algorithms the mankind is to discover is in the fact ancient knowledge (it is difficult to be read immediately as it is coded or, if to say this in a modern language, is a cryptogrammic one). It is dangerous and open to those who change themselves in the process of its studying or makes those who study it for egoistic reasons mad. It is amazing! It is the thing the modern algorithms lack of. It was Alfred Nobel who said: "New discoveries will bring the mankind evil, rather than good." Thus, the goal of studying and usage is of significance. The following statement of Prof. A.A. Minaev, Rector of DonNTU, and academician of the NAS is very important: "Now many people are good at computers. They are even virtuosos. But not all of them are able to control their own consciousness and sub-consciousness which is the super-powerful supercomputer" /10/ ( from the point of view of the authors nowadays not every person has such a possibility of the

potential development which is stronger than any computer in the world connected to the Internet. But the situation will change soon).

**Gaining the meta-knowledge through the Internet.** To understand a problem we should move it away. The more the distance is, the better the matter is seen. As we say, the great is seen at a distance. V.V. Pak (the Department of mathematics of DonNTU was called after him) wrote about it. This great mathematician and scientist first spoke about it at the meeting with power-engineering students at the Department of Industrial Companies Power Supply in 1997. There are some pictures taken at the meeting. The administration of the Faculty always created the conditions for the implementation of new ideas and useful unusual innovations. It is not a surprise that it is the Power Engineering Faculty (PEF) of DonNTU that established the workshop with participation of outstanding scientists of nowadays. The workshop created the growth medium for the ideas and their discussion and later resulted in a number of projects: Moscow interdisciplinary conference, the University of Culture restored after 50 years of oblivion. By the way, this structure was presented as an additional result of the work at the European grant TEMPUS (JEP-27085-2006) in which the authors of the paper took an active part. The investigations showed that it was impossible to raise the level of economics without the raise of the culture level. The role of the PEF as the founder and leading executor of the project and ideas implementing it is vivid. So, the first postulate is as follows: the more the distance we move away is the more accurate the forecast is. The second postulate was expressed by an amazing Ukrainian scientist G.S. Tesler in "New Cybernetics" /11/: «There two important to us results in the books of Gödel- impossibility of the mathematical argument of consistency for any rather wide system (energetic fits this definition) which includes all arithmetic in the frames of the system, and existence of the principle of limitedness of the possibilities of axiomatic approach. Not a single solution of the arithmetic system can make it complete. Both of these contradictions can be solved only on the basis of meta-theories and met-approach. Though the results are proved for arithmetic they, as it turned out quite often, have common methodological character and can be applied to the systems of any nature » /12/.

**Knowledge hierarchy** What is knowledge? According to its definition "knowledge is the ordered collection of new characteristics of the subject, world, and their interrelations presented in the form of the particular meta-text. The knowledge does the transformation of fragmented images into the systematized valid form and keeping of all that can be saved, transmitted and developed. **The problem of knowledge, the structure, appearance, specific character of its perception, cognition and out-coming of new**

**knowledge ( creativity) is a philosophical, methodological, natural-and scientific, humanitarian and applied problem which is almost the most difficult one» /5/. In this paper we offer the hypothesis of the knowledge hierarchy: information-knowledge-Meta-knowledge.** The usual unstructured information is the basis on which the knowledge (let us call it the applied one or necessary for the everyday life – earning daily bread) is formed. The knowledge from the capital letter is the knowledge that gives a chance to find the way to the Eternity. It is finding of meta-knowledge historically given to the mankind through the prophets and Teachers. The knowledge was obtained through the insight one of the states of consciousness which is being thoroughly examined. Jacob Bohme, a shoemaker, William Blake, a semiliterate engraver, uneducated prophets Ezekiel and St John the Theologian with his frightening Apocalypse the uneducated person K.E. Ciolkowski after whom the Scientific Academy was named had the insights like that. Let us also recollect Edgar Cayce and John Keely /14/. This is the way of cognition of all outstanding people as well as the energy of all the times and nations of Nikola Tesla. “The Space models the face of the Earth”, - said V.I. Vernadski the portrait of whom is in the office of DonNTU’s Rector.

**Meta-energetic** We have written about the phenomenon of N.Tesla in the proceedings of PEF several times / 14, 15/. He was not the only one among the engineers. John Keely /16/ was a genius in mechanical engineering and had his own unique as to its inner essence principle which allowed him to direct and control the energy of the special air. He succeeded in bringing it down to the earth more than any of the mortals living in his century though he was not initiated into the final Mysteries. Though his devices worked on the air force, Keely’s own psychic energy of the inventor was the “trigger” putting it into action. **The achievement must be considered the prototype of the far destined to the mankind possibility to get the energy not from the planetary interior but from the Space depths.** That is why John Keely and N. Tesla can be called the Messengers of the Future. An ordinary person is keen to know why this cannot be repeated now. The answer is as follows: “The representatives of the modern Fifth race who are too deep in the substance were not allowed to use (especially on the commercial basis) the spiritual spatial energy as because of its limitless destroying and creative power they can expose themselves and other people and the life on the planet to danger» /17/. N. Tesla actuated the air out of which he got the energy for his engines in some different way. This is a complicated and delicate issue. Whether the mankind will pass from the usual energetic to the meta-energetic (the term is introduced below) which is the nonfuel ecologically pure energetic of the future depends on its

solving. Many people living on the Earth planet dream about it. It is real. According to history the ideas and inspiration for technologies were got from science fiction. The majority of them are implemented into products (flights to the Moon, robots, the submarine, the Internet) etc.

**PEF and DonNTU's contribution to the meta-knowledge understanding.** We wrote about it at the beginning of the paper. It was absolutely vivid in 2008 when one of the representatives of the PEF was working at the Internet resource devoted to the perception of this meta-knowledge. He was doing it under the supervision of the Head of the Department, Dean, and staff of DonNTU. First the material was accumulated and discussed at forums and different related projects. There are more than twenty of them. The history and scientific explanation to it are given in the paper /18/. The project work started in 1991. In 1997 within the project Oriflamme <http://roerich.com/> the electron library on the synthesis of science, religion, and philosophy was noticed in the network. It got Ukrainian awards and some international ones (in 2008)/19/ that proves the recognition of the meta-knowledge itself. International experts called it the best world project of 2008 related to the synthesis of religion and philosophy. It was awarded an international diploma in the nomination "Keeping of the Roerich's Heritage". The diploma was handed in to a representative of the PEF in the Hermitage. The procedure was carried out by the chairperson of the world-wide known club of the residents of St. Petersburg Michael Piotrowski /20/. There is no doubt this is the merit of the staff of the Department, Faculty and University. For the awarded person it is a huge advance and motivation to work, he so called future support. This work is the contribution into understanding of the idea of the library.

**Knowledge of all the mankind.** The project "Oriflamme" is the implementation of the ideas of the scientists from St. Petersburg /21/: "Knowledge from the point of view of a separate person is the information on the possible results of the future process in which the given person will take place, on probability of implementation of favourable and unfavourable results, methods, and means of influence on the probability. There are a considerable number of elements of the knowledge of some people that can be good for all people or the majority of them. This knowledge can be considered the knowledge of the mankind. As all people are interested in it, it should be organized to solve three tasks.

1. Maximal (free) access to the knowledge for practically all people through books (libraries), newspapers, radio, television, newsletters, Internet, Synergonet. With these means the survival of some people and the mankind as a complicated self-organizing system is increased.

Any man-made structure, which prevents the knowledge dissemination through the force, financial limitations, and false information, only worsens the mankind's future and, therefore, some of the quanta. From the point of view of the mankind as a wave it is a criminal one. This idea can be the criterion of criminality and totalitarianism of different regimes irrespective the level of democracy they think they have. One of the main, and may be the most important criterion of the power criminality is not only the number of people killed by the power, but also the amount of the general knowledge of the mankind which was not disseminated to all members of the society *free of charge*.

2. Provision of worth-while life to all people taking part in getting and disseminating of the knowledge necessary for the mankind's survival as an entire wave. It is a problem of the material and informational existence of scientists, teachers, journalists, cultural workers and religion figures. We think of the meta-knowledge as far as our terminology is concerned. It is partially implemented in the Oriflamme project carried out and supported by the PEF of DonNTU.

**The meta-knowledge examples.** Here are some quotations about the future of power engineering and the society itself implemented in other spaces of the objective reality. "We have no factories, machines, and plants. The spirit apparatus has replaced them. We have all people need. The Earth gives birth in abundance and the people have everything to cater their bodies. They have to work much and hard. They work physically to keep fit. The main sphere of their work is the field of thoughts and subtle energies. The forces of nature and the element are under the human's control and subdue the people completely. The forces are powerful and inexhaustible. The space gives everything the mankind needs in the sense of **energy**. You work so hard to get a new type of working energy. Fire energies are in man's service and are used with the help of man's microcosm. **We are close to implementation of the great task- to arm the mankind without any device.** The Life Fire Doctrine is common for all the inhabited worlds, and the fruits of the Highest Knowledge are widely used here. I inform you, the earthlings, about it for you to know the main direction of your mankind's evolution and the life forms implemented by us could be desired and reachable on your Earth planet..."/22/. About science: "Our sciences differ greatly from yours as they are based on the Concealed Knowledge of the Space Laws common for all the Worlds. The Concealed Knowledge which you have on your Earth differs from the official science because the latter, being very young, has a blind approach to understanding of hidden nature forces and secrets of the essence of man's microcosm. It denies much because of its ignorant self-importance.

That is why it is one-sided. With us the real practical knowledge and the Life Concealed Doctrine are combined and the Space Secrets and those of subtle energies are in our service in the current life” /22/. The conclusion is like this: “Not dreams, fantasies, groundless imagination but the indisputable knowledge of the spirit will bring you to the depth of the Space and Far Stars. You are to comprehend the space way of man. You can’t do it if you don’t know the Far Worlds which are given to you as a prototype of your further achievements, as the leading force, the goal...” /22/.

**Interim conclusions.** We cite the meta-knowledge fragments which are to be decoded for us to understand how the engines of Kelly worked, how N.Tesla transmitted energy without losses and planned to supply Earth with nonfuel and ecologically pure energy (all this is understood by the energy-informational concept). The task is worth working at even though the fact itself seems impossible as impossible was everything the fantasists had written about. Sooner or later all became a reality. The main thing now is for the mankind to deserve the Knowledge it faces. Ethics is the main criterion or the safety measure to communicate with the meta-knowledge. Thus, the task is as follows: **to develop and comprehend ethic algorithms of the universe.** “**The knowledge is related to obligation and responsibility.** The responsibility for the gained knowledge is big. The knowledge is given not in vain and not for fun, but for its strict **application** in life” /22/ L.D. Landau spoke about it: “There are natural, unnatural, and supernatural sciences”. We think the ethic algorithms belong to the super-natural ones.

Here is the viewpoint of energy and information pedagogic on the subject-matter /23/: The energy and information human being is included into the energy and information field of Earth and the Universe. The energy which is inside us is the done which is outside. Let us think about the conclusion. The result is as follows: all the information that is in the Universe is inside us. We live with it. It is ours and at one and the same time we are its particle. Man might have been called the “micro space” because of it. Not because he is a very complex and well-organized organism, but because he is connected to the huge stock of the space energy and information and keeps it inside him physically. “Omne mia mecum porte” is an ancient aphorism indicating man’s self-sufficiency. To be impartial we should mention that it lost its original meaning in ancient Rome and according to thesauri it means that a man has anything on



himself that belongs to him. It has the spiritual meaning first of all. The man has anything that belongs to him in himself. It is the information and the Universe wealth. He can take and perceive as much as he is given according to his thoughts and actions.

The process of thinking is the result of the interaction of the information field of the man with the information fields of the Universe and the environment where he lives. The environment in this case is Earth as the society where he lives. Some research aimed at finding the independence of scientific discoveries on the places they were done, were carried out in the year before last. The number of the discoveries and the probability of new ones turned out to be much higher in powerful information environments – large scientific centers and laboratories where a lot of people work. People become “cleverer”, talents are revealed and great researchers grow sooner here. The effect of “feeding” of every scientist with the energy of the general information field is obvious /23/.

Today the thinking process is the interaction of the brain with the “database” which is in the information fields of Earth and the Universe.

The Noble Prize was awarded to the English researcher Ackles for the discovery in 1994. He had studied the mechanism of interaction of the man with the information fields. It appeared that there was no consciousness in our brain. The brains had a function of the acceptor (the thought invader) but not of his producer. It can not think independently, but accepts and processes the thoughts of other people claiming them as his own.

The man’s brain is only a receiver. It resembles the telephone station with the relay system that connects him to the energy and information field of the Universe.

The brain can generate simple thoughts independently: there is no need to turn to the space bank to solve the problem whether to eat an apple now or in the evening. But when the matter is in really great products of the thought- hypotheses, theories, and concepts – he can not do without the participation of the Universe information bank. An example is the “illumination” that appears when the man works hard at a problem and sends continuous and more and more powerful requests to the Universe information bank /23/.

Researchers are not always willing to reveal “know-how” of their work. But when they exchange confidences the explanations are one and the same: the illumination comes after long period of thinking all of a sudden, and the necessary conclusions appear by themselves. Someone, like D. Mendeleev, had a dream; someone saw an image of a hanging bridge, but many suddenly discovered that they knew how to do it. It’s the “know-how”, in short.

But apples fall down not on all people’s heads. When A. Einstein was asked how he had discovered the relativity theory, he answered he had been thinking at it for a long time. Indeed, to understand something in the world one should think hard and constantly and for a long time. One is to be ready for the search. The Bible says: “Knock and the door will be opened. Look for and you will find”. Ackles says that the genius is just a constant and organized link with the information field.

The discoveries of Ackles prove that the consciousness is not in the brain. It is just the “telephone station” that connects us with the energy and information field of the Universe.

The brain accepts the vital energy from the outside and generates its psychic energy on its basis. The brain is nothing without the exchange. The psychic energy is the general and final result of the brain work /23/.

The results of the research carried out by P. Fenwick from the Institute of Psychiatry (London) and S. Parina from the Central Clinic of Southampton was published in 2001. They got the proof of the fact that the consciousness does not depend on the work of the brain and goes on living even when the processes in the brain are over. According to the researchers the man’s consciousness is not the brain function. If it is really so “the consciousness can go on living after the body’s physical death”.

“When we research the brain we see that the cells of the grey substance differ from other cells of the body as to the construction. They generate protein and other chemical substances too, but they are unable to create subjective thoughts and images which we define as the human consciousness. We need our brain as the receiver and transformer. It works as the “natural TV”: first it gets the waves than transforms them into the image and sound which compose the integral pictures” /23/.

Numerous models of exchange of the energy between the brain and the Universe have been developed. We do not doubt the main principle

although other important ones can be guessed. For example, the body's energy centre and the "antennas" tuned in to the energy channels were not found, the mechanisms of the interaction of the energy fields were not understood. A number of fantastic projects were described in the special literature. It is inadmissible that so many clever people might be mistaken at one and the same time /23/. The consciousness is not the product of the brain activity. The brain is not the stock of our knowledge. All the knowledge is in the energy and information sphere of the Universe. The man can request it from there and use it /23/.

Studying is necessary. It requires much time and power. But it must be different. It must develop the brain functions, its power and ability to generate the request and understand the information obtained from the Universe information bank. Studying carried out with the help of an experienced teacher forms the abilities to be connected to the energy and information field of the Universe and get the knowledge out. The pupil's task is to develop the main organ of the studying which is the brain. "The things" are not adapted to it.

Studying is necessary to develop the man's brain power which in its turn increases its ability to penetrate into the higher levels of the knowledge. The trained brain differs from the untrained one by the power of the energy and information field /23/.

**Egregors of the thought.** V. Puck spoke about God or the space data base. There is the metaphor in the energy and information paradigm /23/: "If vibrations are preserved, they are concentrated into the common universe information bank, the common universe intellect into which all energy flows of the alive and dead people are included. The common universe intellect knows everything about everybody. There is no doubt that the same thing occurs in other inhabited worlds. That is why the energy and information field of the Universe, the essence and the contents of which are more and more vivid, is the objective reality. The future of the human being is to find more efficient ways to be connected to it to correct the mistake the mankind has made.

We would like to be concentrated on the so-called "*forms of the thought*" which are supposed to be the units (quanta) of the human space thinking. The forms of the thought are also the way of interaction of the man with the energy and information field. They are fields generated by the

man. They are formed by the man's thoughts and his energy. They are also related to the brain activity. The more often one and the same thought is generated the more active and viable it becomes. The expressed **thought is to correspond to the vital demand of the man and to the objective reality.**

The thought generated by the man is the wave that influences both the man and the exterior. The wave is continuous by its nature and endless. If it is constantly supported by one and the same thought it can be spread throughout the Universe.

As a result the form of the thought of the man (egregor) is formed" /23/. We would like to form the hypothesis that the eregor is the concept which is the equivalent of the noosphere in the energy and information paradigm.

*We need to distinguish knowledge from awareness. The knowledge is always related to the thought and the awareness –only to emotions.* The knowledge is connected with its practical application. The awareness is rubbish that spends our psychic energy and is never applied in our everyday life. To get the knowledge we need to sift through a pile of information. The information is transformed into the knowledge when it is comprehended, checked and applied into practice /23/.

According to the research the brain can not think. The power of the general energy and information field pushes it to the thinking process. The thinking quality is defined by the system of the brain-field, and, in fact, by the system of God-man. God has given to the man all he needs in his life, but how to use the gifts is up to the man. The energy exchange quality depends on him. If the man can not arrange it, he is deep in his subjective world. He builds up his closed inner system-the consciousness- instead of the system of God-man. In the course of time this brain function dies out and the man turns into the subordinate creature.

The situation is different when the man builds his own system of God-man. The brain is connected to its natural source – the energy and information field in this case. The thinking process is fed by the God's vital energy and the highest part of the brain (neocortex) becomes active. The man's thinking becomes objective, systematic and universal. His consciousness is clear and he knows about events before they take place. His intuition helps choose correct actions in any situation /23/.

If the man wants to live a happy and long life his cognition process is to be long and continuous. We mean his ability to get the answer for any question from the information field and to analyze and generalize it, and apply to the certain situation. The continuous thinking depends on the choice. Which system to choose is up to the man /23/.

**Ethic algorithms** Algorithm development genesis takes place while the space laws are understood. The laws are expressed in genetic algorithms, neuro-algorithms and the computer as the understandable algorithm of the man's left-sided thinking. But this hasn't given a good result so far as the amount of the knowledge that is learnt badly is growing. What shall we do for the knowledge to work for the evolution only? How to protect the knowledge from being used for the evil? The answer is as follows: we should learn from the nature. There is a famous saying that everything which is new is the well-forgotten old. We do not discover anything new in the issue. We only open the old slightly. We think the algorithms exist. They were used in ancient books and esoteric texts. Let us speak about the Bible (or the Quran or the Veda). They are coded and the reader understands as much as his inner state allows doing it. The one who knows the keys (they are thought to be 7 – mathematical, astrological etc.) understands them. According to the nature laws if the reader improves himself he understands more and more even if he reads one and the same thing. The one who does not change himself makes no headway until he finds the solution. Of course, there are some exceptions, black magicians, for example. The nature allows them lawlessness for some time but sooner or later it puts everything into place. Thus, we open the ethic algorithms (the nature cryptography) slightly. While reading cryptography books we come to the conclusion that the universe controls the man without breaking his will and teaches him to move towards the evolution. Here is an example taken from the Sides of Agni Yoga/22/: “The Light coming is preceded by the intense darkness. When the darkness comes to its zenith the forecast will become a reality. Thus you have the sign to judge upon. Everybody will bring something personal that depends upon the consciousness size to the construction of the Future Temple. For the new to be created the old is to leave. The old should make a sacrifice to the new. Many are suffering and will do it. But the evolution does not take into account either victims or sufferings. The entire species of plants and animals are destroyed in the

name of the final goal. Races and civilizations die to give the place to new ones. Luxury of Babylon, knowledge of Egypt, power of Rome, culture of Greece was replaced by new forms of the state life and buried the past under their debris. The nature is generous-destroying some forms it immediately creates new ones to replace them. The life of a person and his personal interests mean nothing in the flow. According to the life law everything which is alive clutches at the life but dies in the endless form change but preserves the essence that finds a new more perfect form under the changes. The form is nothing but the essence can not be destroyed. The experience that the form gains enriches the endless seed of the energy grain, and improves, and transforms the essence that does not die. The life essence potential in its physical form, which is nothing, is also inexhaustible. The eternal and immortal become apparent in the mortal to show their essence in the evolution endless process”.

**Ethic algorithm essence** According to V.V. Puck the main problem of the information (or post-industrial) society is the absence of the criterion of the information quality. But the culture knows what is useful for the evolution and what is not. How can we distinguish one form another when the evil dresses itself up as the good? We need the ethic algorithms that have existed in the nature to do it. We often think about the visible universe and forget about its invisible part which is registered by devices that widen our knowledge. We can not be objective as our knowledge is very limited. We know only about 5% of the substance the universe consists of. 95% of the universe mass is collapsars the composition of which we do not know at all. G.I. Tesler has a hypothesis that they consist of the information /11/. Here is a real synthesis. V.V Puck said: “Ancient knowledge is to be transformed into scientific formulae”.

**The noosphere epoch new researcher.** What is he like? It is not the researcher we used to think of (a skeptic that does not believe in anything and doubts everything).

He is to burn but not just to be. We can read in /24/: “Do not think that our brotherhood is hidden away from the mankind by impassable walls. The snow of Himalaya that hides us is not an obstacle for those who look for the truth but for those who are just curious. You should distinguish between the one who seeks and the skeptic. Be absorbed in our work and I

will help you on the way to that world”. “Any researcher of the doctrine can get the following advice: advance with all of your power, observe by all means, research by all methods, and dare to learn, be tireless and burn from every finding of the truth. The doctrine can not be false.” /25/ The world multidimensional nature is to be taken into account. The hadrons collider has been built but if the universe multidimensional nature is not thought of, it is a meaningless thing, from our point of view. There are a lot of examples that prove it:

-“Many theoreticians are sure that the concept of the multidimensional space has all the chances to be one of the cornerstones of the new paradigm of the universe structure. It is shown in the theory of multidimensional membranes (M-theory) which is the development of the theory of strings. According to the M-theory the space has 11 dimensions” /26/ /27/ says: “Urusvati knows that people complain of unexpectedness of Earth phenomena. They might say: “We were waiting for it with our entire wish, but nothing has shown itself. But when all our power was over, it appeared”. We should comment on this: “You wanted a subtle display of your secular wishes. Can’t you understand that the earthly and the super-earthly can not be in one dimension?” /26/

- The application of ethic algorithms is the change of yourself and understanding of the new science for the common good.

- The transfer to the new synthetic thinking. “Only ignorance can think that all can be cut according to your own measure. These people act against space laws. They can not be called scientists as every true scientist is to have wide assumption...

The most remarkable discoveries can show the transfer of the researcher’s brain into the synthetic generalization” /26/.

**Distant learning at the new stage.** In the basis of the education energy-and-information paradigm /23/ we can drive to the conclusion that learning process is to be as close to a student as possible. The Skype technology when both a teacher and a student see each other on-line is the most convenient now. But the energy of one practically does not meet the energy of the other. There is only a video and sound contact which is good but not enough. In this case the auras of both do not touch each other. It is a well-known fact that the atmosphere of the laboratory a researcher works at is the catalyst of his research activity. The teacher energy field might be

added to on-line broadcast. The effort might look poor as the machine is only a prop for the man. The man is to discover its own inner reserves 95% of which have not been used so far /28/. The evolution significance of engineering is in showing the possibilities the man will face: the transfer of a thought and an image on a distance (a camera and TV). The Sides say: "Let us take TV as an example. People limit its power by the bought device and become dependent on the TV centre and its programme while they have more perfect and absolutely free device in their brains and psychic organization. The people use it constantly and do not understand it. The man thinks by images. Different pictures appear in his consciousness and change each other. The process is automatic and is not controlled by the will. The thoughts flows are weak-willed and the corresponding images are weak-willed too. If there is some work to do the conscious images contact the will and it gives them the direction but does not control their flow. The trained brain of the researcher brings an order to the process, but there is no understanding of the phenomenon and its power in it. The fiery psychic device of the man is wonderful. It can be mastered to be perfect. You can take any ancient thing, concentrate on it and see all vibrations that have ever appeared on it. Not only man has a power of seeing and keeping the visible things on him, but an animal a plant and things and the matter they consist of. The matter but not them is full of not studied power has this wonderful characteristic. But the characteristic is to have a key. The man who can see and hear everything fixed by the matter or by the nature memory has the key. Akashi's scrolls are reflected in the matter the forms of which have not been recognized by science yet.

One thing is unquestionable: the thought is often accompanied by the visual subtle impression. The man sees the image of the thought that appeared in his consciousness by this eye. If the thought is concentrated on the certain question, the image flow will happen in accordance with the question. If the thought is concentrated on the certain thing with other thoughts being excluded, and then is put aside, the vibrations coming from the subject will speak and spread their energy in front of the consciousness, and you can see fragments and then the entire pictures of what the thing saw around it once.

The walls of ancient buildings have seen much, much is seen by the walls of dwelling houses and they imprint everything that takes place inside



them. If the man's centres are subtle enough, he can also see it. The strata cause many transient and incomprehensible feelings. Unfortunately, people do not wish to realize what they see, hear and feel behind the stereotype. We can feel both man and things. Women are more sensitive in this respect. Before man is able to unlock the wonderful device which is inside him, he will need to demonstrate keen vision and power of observation as to his impressions. First he is to know about the device existence, then to understand its possibilities and value, and then to activate it carefully and step by step. The coming new fiery epoch gives the man new opportunities that require comprehension first of all. The ability of the man to see with the third eye and arouse the image of any thing is to be paid a special attention to. Too little attention is paid to the amazing creative ability to make desired images out of the subtle matter; however it is the basis of everything that has ever been made by the man. The man can not create anything without preliminary forming of images invisible for man's eye of what he wants to implement in his earthly life in their visible forms. First of all it is he who sees the images created by him. But some other person can also see them, invisible for an eye, by his third eye. When a listener hears about a new construction plan or draft he sends desired images to his consciousness with the help of words. But the perception can occur directly, without any word. The thought transfer is based on it. So many thoughts and images are transferred and received every hour without the process being understood! There are many people who deny the wonderful world around them and the possibilities they have in their hands. They should forget about their denials and just open their eyes to see. The man can see and hear beyond the usual abilities /22/.

Man's aura investigation (its symbol is shown on the example of the toy Russian dolls). We can also speak about the aura of premises and people. When we come into it everything goes by itself and understanding of the previously impossible things takes place in the team and the room. The ordinary knowledge (horizontal, for the life earning) can be broadcast on a distance. To understand something which is deeper we need to make our own way to the teacher. There is an oriental saying: "The teacher comes when the student is ready". It is great luck for both. The Sides says /22/: "The intimacy with the teacher is to be looked for in the spirit. It is accessible in the spirit. You can be elevated by the spirit with your body

being fined. If the spirit is high it elevates its coats as a balloon raises a basket with its ballast. Spiritualization of physical, astral, and mental matter made by the spirit mental fire takes place. The evolution goal is to spiritualize the Earth and its physical spheres and transform the rude into the spiritual and fiery". It is a super task, the future distant learning. The traditional approach to education is in getting a book, a leaflet, or a film. It is not a problem in the information epoch as the knowledge is accessible (open and noospheric libraries). But there is a problem in the knowledge extraction. The real (vertical) knowledge is usually coded. It helps laymen. The Bible has seven keys without which it is impossible to understand it totally. When a recipient gets the knowledge because of some reasons and uses it in super selfish ends it is called the black magic. The space laws are legal on the Earth and behind its limits and not only in this but in future lives. This means that punishment will take place anyway. The birth of monsters is explained by it. It is not only the fault of parents (sometimes the monsters are born from decent parents). The future of distant learning has two versions. The first is the traditional one – the inner improvement (computers, communications, and software). The second one is oriental – self-improvement and the teacher will come in time to him who knocks at. /22/ illustrates the idea: "The wish to get the certain knowledge predetermines its getting. It also concerns any strong and legal wish. It becomes a reality very quickly. We help in everything that concerns the common good".

**Conclusions.** The innovative approach of the energy and information concept of education development is a decisive one /23/. Different education technologies (distant learning in particular) can be developed in the frameworks of the concept. The mankind will be faced with understanding of ethic algorithms of the universe which are paid attention to in the paper. We might take a technocratic lesson (of inner perfection) at the new stage of the mankind's development and come back to the life simplicity when there is no need in machinery. Then we will not need the distant learning as teacher's coming to a student might happen in any space of the being. "The phenomenon simplicity is not accessible for people as the life great laws are too simple for the people to accept them without wandering around. All which is great is simple. As far as the simplicity is not typical for people the great is difficult. Communication in the spirit and

by a thought is easy and accessible. But who believes in it? How many years did we need to get into contact with Guru? Thinking wheels rotate slowly as there is no simplicity...”/42/ We will learn **the “new” method of knowledge getting to which the evolution is preparing us**: “How big is the amount of interesting findings the man faces! The entire world is open for learning but not through the brain. The communication goes through the same channel through the heart. The heart grows and is deep in the subtle work. We should develop feelings. The knowledge comes to their centres and reaches the consciousness. The spirit knows much. The knowledge of the spirit and the feelings are inseparable. Both mean the direct knowledge without interference of the brain. When the consciousness is concentrated on getting the direct knowledge it gets it if the brain is not allowed to interfere into the process. The brain in this case acts as an accountant of the facts that come into the consciousness. But the knowledge getting itself takes place without it. The spirit and feeling knowledge is a new method to get the knowledge and obtain the information for the subtle consciousness.” /42/ We will not need ordinary libraries as we will use the natural ones as all the knowledge is in the noosphere and can be got from there directly. It will be a new stage of the mankind’s development. Esoteric sources which are accessible for people show how to get there.

We would like to wrap it up by citing the Sides: “My son, the feeling that you can perceive and fix the thoughts that come from the space is correct as the access to the space thought depository is open. There also is the access to the thought ocean. The learning ocean is open only to the nearest. The ability will be clearer in the course of time. It won’t be limited by the communication hours; it will always be open if the spirit wants it. The ability comprehension is to be introduced into life and be used if there is a wish. It is as if you always have the telephone set at your hand and you can be connected to the desired object or as if you have the radio set and can listen to the favourite channel any time you want. The spirit device is much better than the devices that have been invented, are being invented or will ever be invented. All of them are just a rough imitation of what is inside the man. Lenses, binoculars, colored photos, films, the telephone, the telegraph, the radio, and the TV and vibration devices are inside the man in the forms that are more perfect than the physical devices. The binocular is to be regulated according to the eye, but your eye does it automatically.

You need some time to get a photo. Your brain and your eye do it immediately. You even need some time to send the radio telegram. Your thought is as quick as lightning. You do not need to go to the cinema theatre to see the film. The person who drowns sees his life as on the film. But to see the event astral films you do not need to drown. If you have such ability, it can show itself in more appropriate conditions. It is good to fly being on board plane but it is faster, cheaper and more interesting to do it in the subtle body. Everything is inside the man. It is to be understood first and then the abilities given to you by your body are to be applied. It will be your great inheritance prepared by Father of everything to his prodigal sons. Father is waiting and so is the inheritance. Come and get it. It is yours from the time being”.

The new understanding (from the metaknowledge) of the machine essence is one more crucial conclusion: “The machine is an interim phenomenon. It is true, that some devices will remain for long even on the highest plans, but the final goal is to be free of mediating devices and operation of the spirit fiery power when the devices are concentrated in the man’s micro scheme. The planet creator acts without any device. There are no devices in the infinity. They exist on the prototype plan as models of what can be implemented on Earth at a proper time. We need to understand and use the man’s fiery devices such as the telephone, the telegraph, the radio set, the camera, the TV, the device to project space cliché of the past, present and future on the consciousness screen in the third eye. The sound and hearing set allows hearing in the distance, the visual one – seeing. The energy set allows transferring the energy both in the distance and during the direct contact. Harder energy types which the man uses when he works, moves etc. are obvious and are not to be proved. We can feel an electric impulse run on nerve wires and carry the fiery current of psychic energy. The man’s device is extremely complicated and its power is inexhaustible. Thus we need to start mastering it and apply the wonderful devices into life. The man constantly radiates different energy types. They can be directed consciously. Their power is extraordinary if they are understood and the will controls them. There is no way except for mastering all the wonders of the fiery device which is inside the man. You can not study them theoretically. You should just live and apply the learnt laws of the subtle laws in your life” /22/.

## References:

1. V.V. Labotski. Knowledge Control: Technologies, Methods and Means of Knowledge Presentation, Extraction and Measuring. Mn.: BGEU, 2006.
2. V. Yemelianov, V.V. Kureichick, V.M. Kureichick. Theory and Practice of the Evolution Modeling. – M.: Physmatlit, 2003. – 432 p.
3. A.V. Nazarov, A.I. Loskutov. Neural Network Algorithms. – StPb.: Nauka I Tekhnika, 2003.
4. V.N. Bondarev, F.G. Ade. Artificial Intelligence. – Sevastopol: SevNTU, 2002. – 615 p.
5. A.I. Klizovski. The Grounds for Understanding of the New Epoch. - [http://www.roerich.com/zip/os\\_mirop.zip](http://www.roerich.com/zip/os_mirop.zip)
6. A.A. Makarov. Great Laws of the Space // Delphis, №3 (43), 2005.
7. P.F. Belikov. The Family of Roerich. Spiritual Biography Practice.
8. E.I. Roerich. Letters. Volume 2. – M.: MTR, 2000. - [http://www.roerich.com/zip2/ei\\_2.zip](http://www.roerich.com/zip2/ei_2.zip)
9. E.I. Roerich. Letters. Volume 1. – M.: MTR,1999.- [http://www.roerich.com/zip2/ei\\_1.zip](http://www.roerich.com/zip2/ei_1.zip)
- 10.A.A. Minaev. Speech in front of Master's Students. - Donetsk: Donetski Polytechnic, №14-15.
- 11.G.S. Tesler. New Cybernetics. – K.: Logos, 2006.- 2004.- p.57-58.
12. L.N. Melnikov. The Virtual Reality and Space Consciousness // Delphis, №2 (46), 2006. – p.111.
- 13.D. I. Shapiro. The Virtual Reality and the Problems of Neurocomputing. -M.: RFK-Image Lab, 2008.
14. A.P. Kovalev, S.G. Dzhura, L.V. Chernikova. Energy Risk Control (to the 150<sup>th</sup> anniversary of N.Tesla) // Proceedings of Donetsk National Technical University. Series: “Power Engineering and Energy”, issue 112. – Donetsk: DonNTU, 2006. - 151-153.

15. A.V. Levshov, A.P. Kovalev, S.G. Dzhura. On the Track of the Solution of the Phenomenon of N. Tesla // Proceedings of Donetsk National Technical University. Series: "Power Engineering and Energy", issue 7 (128). – Donetsk: DonNTU, 2007.-11-13.
16. T. Pimans. J. W. Keely – the Discoverer of the Free Energy //Delphis, №2(42), 4(44) 2005; №1-4(45-48) 2006; №1(49), 3(51) 2007; №2-4(54-56) 2008.  
<http://www.roerich.com/delfis/index.html>
- 17.E.P.Blavatskaya. The Secret Doctrine (in three volumes)- Kharkov: Exmo Pholio, 2008  
<http://www.roerich.com/zip/td1part1.zip>
18. S.G. Dzhura. Social Aspects of the Internet-Communication. The Proceedings "Language and Culture: Problems of Social Communication and Inter-Cultural Dialogue. Supplement to the Inter-Disciplinary Scientific and Practical Newsletter "Man in the Social World", volume 6, Tula, 2003. - p. 42-48.
19. Awards of the Project Oriflamma : <http://roerich.com/award.htm/>
- 20.T. Davidenko. Let the good in and it Will Come Back // Vecherni Donetsk, №166(8798) of 11.11.08;
21. M.A. Basin, I.I. Shilovich. The Way to Synergonet. – StPb.: Norma, 2004. <http://www.roerich.com/zip3/synergonet.zip>
- 22.Sides of Agni Yoga. 1957. – Novosibirsk. Alгим Company. 2008.  
[http://www.roerich.com/zip3/grani\\_57.zip](http://www.roerich.com/zip3/grani_57.zip)
- 23.I.P. Podlasi. Energy and Information Pedagogic (Textbook). – M.: Data Square, 2010.
- 24.Call (Leaves of Moria's Garden) -  
<http://www.roerich.com/zip/zov.zip>
25. The Fiery World, p. 1. - - <http://www.roerich.com/zip/mo-one.zip>
26. O. Feygin. The Great Quantum Revolution. – M.: Exmo, 2009.
27. Brotherhood, part 2-3, Overground.  
<http://www.roerich.com/zip/brtwo.zip>
28. V.D. Pekelis. Your Abilities, Man. <http://biblioteka.teatr-obraz.ru/node/7489>

## **6.2. The crucial role of culture in the noosphere formation**

A.V. Levshov, S.G. Dzhura, V. I. Chursinov

*The choice of the mankind's development vector is analyzed. The crucial role of culture as the development integral criterion is proved. The ways out of the world outlook crisis which is the basis for the economic one are offered. The practice of recovery and development of the Institute of Culture of DonNTU is discussed and the crucial role of culture in the noosphere formation is shown.*

**Introduction.** We totally agree with the task put forward by the international interdisciplinary scientific conference “Ethics and the Future Science” related to the scientific evolutionism and the view of the future. It emphasizes that only a full-fledged synthetic approach in science is able to reveal the signs of the evolutionism in different natural processes and laid down the true vector of development of different objects in the space and on Earth ( under the influence of the external space factors) for all life manifestations. It is to be traced because of the changes on Earth including catastrophes (geological, climatic and powerful changes in the life of the planetary socium) that are happening very fast. We are living in the certain transition period predicted by the Ancient Wisdom (it is the transition from the epoch of Pisces to that of Aquarius in the West, from Kali-Yuga to Satyā Yuga, the Golden Age in the East) which is not short” /1/. We will try to look at the mankind's development tendencies in the light of integral criteria which give approximation to the synthetic understanding of the problems the mankind faces.

### **Visualization of the existing situation in the form of the integral criteria**

The main index of the society development has been the level of the gross domestic

product (GDP), but many people notice that the life on Earth is getting more and more uncomfortable.

The research team of the World Resource Institute (Washington, the USA) headed by R. Repetto (1989) tried to trace the real changes in economics taking into account not only the GDP but also geo-ecological indices. First they did it in Indonesia where the economic crisis

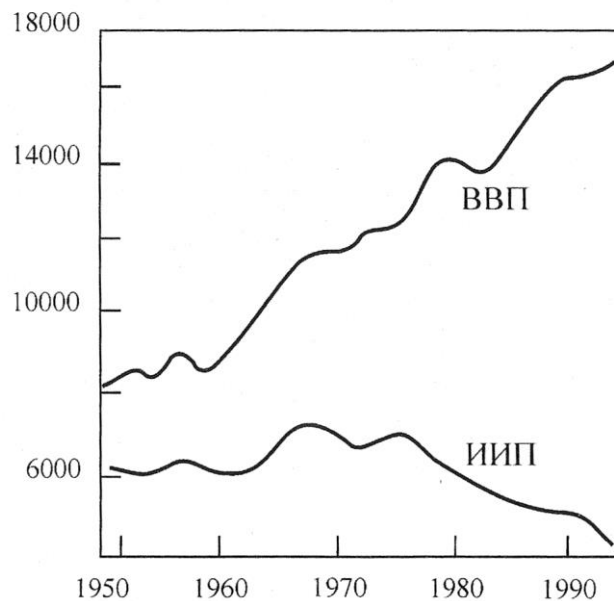

Fig.1 The graph of the GDP and the progress true index for the USA

demonstrated the system instability because it neglected geo-ecological issues /2/. The calculations like this were also done for other countries too. The team of private researchers in the USA developed the index that showed changes in the country's welfare – the Genuine Progress Indicator (GPI). It takes into account more than twenty economic, social and ecological indicators. The GPI is based on the GDP data and is estimated in money and allows comparing of the GPI and the GDP. The graph of the progress true index and the GDP is given in the fig. 1 (according to the US indices) /3/.

The GPI adds some factors such as cost of housework and voluntary one to the GDP and subtracts such indices as losses of the society because of the crime growth or the environment pollution. The GPI takes into account the natural resource state worsening. For example, the increase in oil production is thought as the negative index unlike the GDP. The worsening of the state of the ecological sphere (change of the climate, the ozone layer breaking, and the radioactive pollution growth) also causes the reduction of the GPI and worsens the health of the population /4/.

**Strategy leads to philosophical thinking** The mankind's further development only worsens the life of people even in such country as the USA which is considered to be the standard of the mankind's development.



If the priorities are not changed and the ways of development of the mankind are not coordinated with the global evolutionism the results can be easily predicted by just the graph prolongation. Thus the vector of the civilization development is aimed at destructing of the civilization itself.

Thus we can make a conclusion that the worldly criteria (which have been used so far) are decayed and do not meet the modern stage of the mankind's development. The mankind lost the aim and sense of its development. The words of P.F. Belikov are symbolic: "The world policy and economics have never been and will never be the evolution decisive factors. The evolution is aimed at creating of the man able to think in space categories but not the one who can think correctly. The politics, economics and all the social structures established by them teach the man to understand the matter on minor and temporary examples. It would be ridiculous to think that "justice" and "injustice" of the short-lived forms of the man's social life are typical criteria of the Space Mind" /5/

We think that the Gnostic sources which the previous civilizations ignored (and were punished for it) proposed the real criteria of the mankind's evolution. As to our civilization, we "are hierarchically joining the Great Space movement and are entering the world flow when the spirit takes the evolution laws of rushing to the fire spheres. We should give up the ordinary thinking which marks time. Unboundedness is entrusted. The space rushes to the future. If we join the movement, we follow the law and obey the Highest Decree. None of the local and even planetary phenomena can stop the world movement. **The space wave can remove not only a man, a nation or a continent, but also the entire race and planet if there is the resistance that delays the evolution.** This causes explosions. Arhat thinking is of the space scale and all personal drowns in the space ocean. There is no room for a personality, self and the average man in the highest fiery spheres but there is a room for the man's spirit who lost the soul to find it transformed into the super personal Mortal Personality" /6/.

Sides of Agni Yoga (notes of B.N. Abramov) gave us the true knowledge and the warning that everything which does not evolve and thus degrades has no right to exist and will be swept away from Earth by the evolution wave. The following words prove it: "The mankind as a part of the planet and its highest principles can not leave the spiral of the planetary evolution. Stars drew the spiral rotation cycles. If the time yearly spiral

depends on the Sun, or the Sky, the world evolution entire spiral with an earthly year being its part depends on the Sky and heavenly bodies. The eternal is in the temporary and the temporary is only a part of the eternity aspect, only the small part of the giant spiral of the Life which evolves in Space. We are unable to escape the Space Laws. So we will bring the Eternity greatness down on Earth within the boundaries of the earthly understanding for Earth to be raised to the Eternity. The Kingdom of God has approached as the fiery energies rush from the space into Earth. Their goal is to rarefy the earth dense matter and make it thinner. The evolution assumes thinning-down. The final goal of the circle is to bring the planet to the highest degree of rarefaction when the visible turns to invisible and the patent will be enveloped in the Light Body. Then the man will be enveloped not into rough physical bodies but into rarefied and subtle forms with the intensified astral being their transitional stage. But the intensified astral is only a step towards more subtle and luminous bodies. The rarefaction and thinning-down in the evolution spiral will be parallel to the process in all the planet kingdoms, and the life forms lagging behind the progressive motion of ascension will doom themselves to extinction and destruction as **everything which does not correspond to the Evolution stage becomes extinct.** The way of the mankind drawn by heavenly bodies is great as it is the Light Way and the Way to Light. Will many of us understand the greatness of the future and believe in it?" /6/

### **Globalization of economic and political structure of the mankind on the way to Brotherhood**

Teaching of "The" gives the clear picture of the mankind's future in connection with the transition from anthropogenesis to teogenesis. The following statement answers the question whether the evolutionism principle is typical to the long-term processes that cover the worlds invisible to us: "The laws of evolution and involution do not operate on the three highest stages of consciousness. The laws control the life ascension and digression on the four lowest plans." /8/ The true control of Earth is done in the following areas (Teaching of The): "Now the efforts of Teachers are aimed at solving of the great world problems of religion, education, science and state structure. It is invisible work. They seldom meet people. The members of the esoteric Order of the Teaching The must help the task solving". /8/

We made the presentation of the hypothesis on the synthesis of septenary gradation of the matter, consciousness and force at the conference /9/.

The point of view of Gnostic sources as to the education in general is symbolic: “It is high time we talked. I understand that many of you will not agree if I say that praised modern systems of education do harm and lead our youth astray, that thousands of graduates of universities are not ready to live and pay their debt; the young people disgrace the specialities in which they imagine themselves to be professionals or become traders. The man will be satisfied with the results of the modern education until the current civilization ideal based on material values only rules. When the real idea of the common good captures the people, the modern system of education and many other pseudo institutions will be relegated to oblivion.

I won't go into details but would like to add that the true education is a result of the interaction of man's mental forces with the subject material images. The real knowledge of any subject or phenomenon is a result of reflection of the material form in the ocean of a thought and combination of the life forces of the form and the thinker. The energy two forms meet and match due to the attraction of the subject and reflection of its image in the mind. The combination imprints the stable mental image on the sensitive surface in the man's brain. It is impossible to squeeze the idea into the man's mind; you can only arouse the response force which is in it and cause the idea form due to the interconnection.

I mention the facts to explain why I am against the education modern systems at large”. /8/

We support the approach of M. Cremo and R. Thompson in the book “Forbidden Archeology”: “It is dedicated to the circle of researchers and philosopher (which is getting wider) able to risk the professional prestige, post and privileges in favour of such an ephemeral substance as the truth”.

**Science as a part of spiritual culture** Material values created by man defined the material culture historically. The spiritual culture was created as different forms of cognition and understanding of the being (the world) by the man. Science is a part of the spiritual culture. The value of science is in its desire and ability to discover the truth through the knowledge /10/. Historical science dominates in the being understanding. It is the highest cultural value and gives birth to the faith in limitless abilities. Here is the

concept of mathematical faith as we have it in the form of axioms (which are impossible to be proved). Thus there is the faith category (the religious one as a matter of fact) inside the science. That is why the remark of the Austrian and English philosopher, expert in logic and science, and sociologist K. Popper is very important for understanding of the science essence: “We are to get used to understanding of the science as not **the knowledge totality** but as **the system of hypotheses** that is guesses and anticipations which can not be grounded but which we use until they meet tests and which we are never able to call “true”, “reliable” or even “probable” /10/. The remark is to be taken into account at the conference where the hypotheses on different science problems can be spoken out or discussed with the like-minded using esoteric knowledge which the traditional science is afraid to put into operation so much. That is why we support the conclusion that “the empirical test founded on the principle of verification and falsifiability is to prove the hypothesis validity if there is the research subject” /10/. However the verification in the nanorange achieved by the modern science when even a thought of a researcher can influence the experiment result is out of the question. That is one and the same experiment carried out by different researchers might have a different result and this will not be a mistake and denial of other results as “the verification principle operates only if the concept and the opinion come to the direct experiment. The scientific proposition falsifiability principle is built not on the hypothesis confirmation but on their denial and ban of inventions and arguments that seem true. Thus we drive to the conclusion: the science as the “hypothesis cemetery” (Poincaré) turns into the true science only when all methodological tests are passed and thus any **knowledge has a right to exist**” /10/. We would like to add the phrase – including the esoteric one. We will ground it below. The information obtained from a prisoner for interrogation is taken into account during the war, though we understand that he is a rival and is unlikely to tell the truth. But the information is to be in the research as a hypothesis at least as it might be true (the practice confirms the approach correctness).

**Education as a culture phenomenon which does not look for the truth.**

Let us discuss the official science state and tendencies. The analysis is done by one of the authors in the paper “Philosophical Approach to the

Analysis of Modern Pedagogic (applied in Ukraine)”: “The modern education state which is reflected in pedagogic science both in the theory and practice is the problem polyhedron the analysis of which starts with the main problem – the goal of pedagogic the ideals of which are not in demand, in our opinion” /11/. The paper proves that the modern official pedagogic fulfills only utilitarian function of servicing of the society which issues its social order. That is pedagogic is secondary but her function is to look for the truth. So, it is to lead the civil society to the Truth. A horse and a rider exchange their places, the lower tries to control the higher, so the world outlook crisis is obvious. The situation can not last long. “Economics is the derivative from the world outlook”, Dr. Khendyukov noted /12/. The present society is going the wrong way and the countries which do not fulfill their evolution idea leave Earth in the long run. It is confirmed by the esoteric (Gnostic) source: “The space evolution is taking its normal course. The efforts of the dark to stop it are powerless. Earth is a particular case which does not matter in Unboundedness. Each earthman that joined the evolution is included in the life world flow. The one who moves against the Evolution dooms himself to regress and the final destruction. The evolution wastes are destroyed by passing the long and agonizing stage of decay. You can not go against the evolution for a long time being unpunished. It is better to join it. The fate of some people, nations and even races that do not correspond to the evolution is sad- they are swept away from the life arena. The decay and degeneration can last for ages. We see the races that are leaving and the nations which used to be great and now are worthless. Both Australians and Bushmen are the remains of the former great races. The evolution is not limited by Earth. The way along the stars is wide and endless. The travelers who go along the endless way often do not know their purpose. The fate of man is great but it requires understanding. Otherwise the main thing might be missed” /7/.

Dr. Gindilis /13/ stated the problem of science losing its purpose. He observed the stages of science formation and emphasized the values which are characteristics of the research in the period of formation of experimental natural science. These are universalism, collectivism, unselfishness and organized skepticism. Science has been the application to high technologies in the second half of the XX century. The values of

scientific search faded. Unfortunately, profit, business, the social order, but not the truth understanding is on the foreground.

Thus the majority of the modern research is aimed at solving the social demands. Science is not looking for the truth now (that is it is not fulfilling its main mission) and is satisfied with the role of the servant of business and democracy that lead the country to the disaster. We support the hypothesis that **the goal and concept of science in Ukraine are unclaimed, to put it mildly /11/.**

#### **Education or education services? The science objective function**

The propositions that the education services are to be offered are very popular now. We think it is moving away from the education main task and would like to analyze the proposition.

Science can be analyzed with the help of a dialectical approach and two trends can be singled out. Firstly, it concerns the science utilitarian function. If to speak about pedagogic it is the search of regular links between teaching, upbringing, personality development and building of models, programs, technologies and methods of teaching and upbringing based on them. Secondly, it is the main function of science, which is search of the truth, which is not being discussed widely. Pedagogic is to enter the new level (further on the level is called the meta-level, and pedagogic is called meta-pedagogic). Thus any science that fulfills its utilitarian function serves reproduction of man as a species and solves the problems of his existence and life earning. The worldwide known sculptor Ernest Neizvestni gives his own explanation of the cross symbol: the horisontal bar is what man is to do during his earthly life (to work for having something to eat, living somewhere etc), the vertical bar is what he is to do for Eternity. The vertical line is the main component of the cross and the symbol of the truth search. In respect to pedagogic it is the super goal and the main function of this science. In this case pedagogic, as any other science turns back to its origin – to philosophy.

As the goal of any scientific process can be described in terms of optimization theory ( as the goal is to be reached in the optimal way) the scientific problems can be considered to be the objective function OF ( it is multicriterion one with its own weight ratio in the general case) in the limit area (L-financial, time etc.)

$$\begin{cases} F(x, y) \Rightarrow \min / \max : (Of); \\ x \leq L \leq X : (L) \end{cases} \quad (1)$$

The pedagogic tasks of a university are to have the level of the qualification characteristic of the specialist (knowledge and skills). It is the objective function of the university staff in the frameworks of limits (time, program opportunities- hours and pedagogic and psychological characteristics of a student who is able or not very to get the knowledge).

Now a university tends to give its graduate as much knowledge as possible (though we understand that you can not get all the knowledge even during your life time). But the learning time and abilities of every student and academic are limited.

The problem solving can be found in “The”: “A child leads an adult if the latter is blind. The man who is spiritually sighted but not educated enough can teach the educated one the things which are more important than any recognized systems of education if the latter is blind because of his nature drawbacks or narrow-mindedness. The real wisdom is knowledge and simplicity.” /8/. The truth of a proposition is confirmed by voting at the current Scientific Boards (Socrate’s life was solved by voting). “The” reads:” You must not jump to conclusions. It is not easy to find the reason for any activity. The witness is indisputable if some people come to the single opinion of what they saw or heard at one and the same time. But the Right way Enlightened can not agree with conviction of the man on the witness basis. He knows that the observer who has the subtle sight and ear can see the things which other can not – an interim action or intonation that change the essence of facts and thus refute the proofs and everything they are based on” /8/.

The next group of important questions is as follows: what knowledge is to be given to a student, in which volume, and how? The great pedagogues of the past did not need the explanation of the difference between education and the education services and foresaw the problem. M.Lomonosov said: “The goal of studying is not the knowledge totality, but the thinking correct way and moral upbringing” /14/. L. Tolstoy thought:” The knowledge quality but not its quantity is important. You can know much, but can not know the most important thing” /14/. The words are prophetic.

**Wisdom as knowledge peak** The above problems are not discussed in Ukraine /11/. The researchers start with the method of giving as much knowledge as possible for the student to reproduce it at the necessary moment. Not many teach the thinking art as it is the prerogative of only enthusiastic pedagogues.

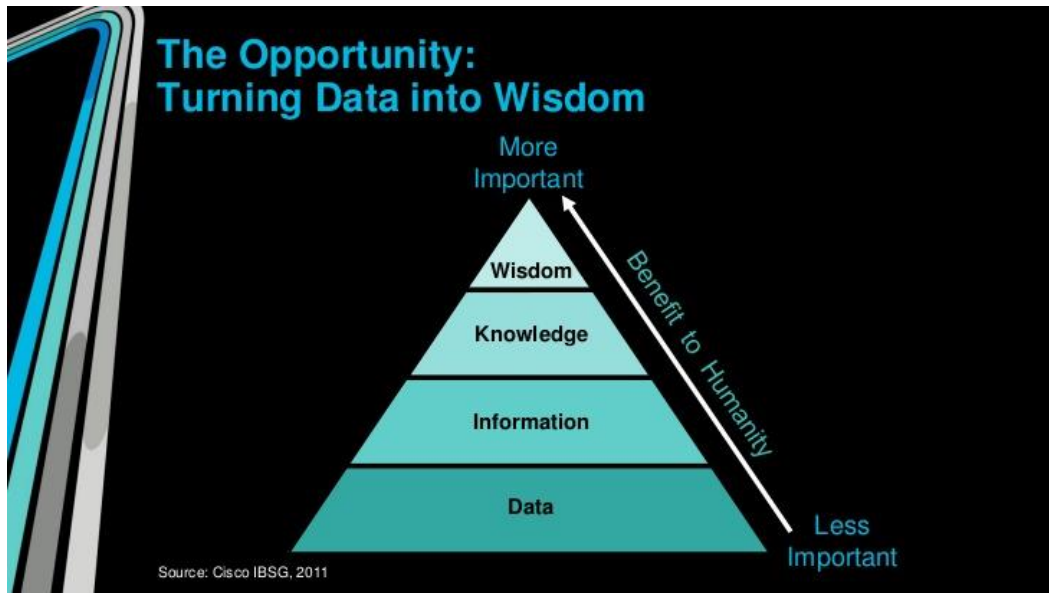

Fig. 2. Transformation of data into wisdom (Source: Cisco IBSG, 2011).

What is knowledge? According to the definition it is “the ordered totality of new characteristics of a subject and the world and their interrelations presented in the form of the certain meta-text. The knowledge transforms separate images into a systematized form and keeps everything which can be saved, passed and developed. The problem of the knowledge, its structure, appearance and special character of its cognition and the new knowledge creation (creativity) is philosophical, methodological, scientific, humanitarian and applied one, and is one of the most difficult problems” /15/. The scheme of the hierarchic transformation of knowledge according to the version of the company Cisco is given in the fig. 2.

The following postulate was suggested by the Ukrainian researcher N. Tesla in his “New Cybernetics”: “There are two important results in the work of Godel. It is impossibility of mathematical proof of consistency for any wide system that includes arithmetic in the frameworks of the system and existence of the principle limitation of possibilities of the axiomatic



approach. Not a single solution of the arithmetic system can make it complete. Although the results were proved for arithmetic, they have the general methodological character and can be applied to the system of any nature” /16/. **These two contradictions can be solved only on the basis of meta-theories and the meta-approach.** The approach is implemented in gnosis and esoteric knowledge. The book of L. Gindilis “Scientific and Meta-Scientific Knowledge” issued by the publishing house of Delphis is the tremendous synthesis of classical science and the gnosis /17/.

**The decisive role of culture** Many people think that the civilization is the main achievement of the mankind, but we support the point of view of E. Roerich as to the Gnostic knowledge which she stated in her letter of September 5<sup>th</sup> 1935: “The civilization forced out the concept of Culture and many people do not understand that you can be a civilized barbarian. They fail to take into account the fact that the cultural layers are accumulated during centuries but the civilization can be created during a ten year period” /18/ The point of view coincides with the conclusions made by classical philosophers who can not be referred to as esotericism supporters.

We are turning to the famous Spanish philosopher and sociologist José *Ortega y Gasset* who expressed the analogous thoughts in his classical research devoted to studying of university education as a specific cultural and social practice. The book came out more than 70 years ago, but its ideas are still significant and even became more topical. “The current situation is sure to cause cruelty for the results of which Europe is paying. The reason for the modern disastrous European situation is the fact that English, French or German doctors are vulgar; they do not have their life system of ideas about the world and man which corresponds to the present time. This average man is a barbarian lagging behind his epoch, archaic and primitive in comparison with the horrible present and his problems. He is a new barbarian, a professional who knows more than ever, but he is a doctor, an engineer, a lawyer and a researcher and much more vulgar” /19/. We know the thesis that a half-educated person is worse than an ignoramus as he thinks he knows what he does. F. Dostoyevski said: “It is a special characteristic of semi-science which is the most awful scourge of the mankind; it is worse than devastator, starvation and a war; it was not known till the current century. The semi-science is a tyrant who we have never seen before. It is the tyrant who has his priests and slaves, who is

worshiped with impossible love and superstition. The science itself trembles at him and indulges him shamefully” /20/. The words of Socrates are very important for pedagogic: “There is only one good which is knowledge and only one evil which is ignorance”. Stephen William Hawking, who is working at the department of the University of Cambridge which used to be headed by Newton, develops the thought of F. Dostoyevski: “The main enemy of knowledge is not ignorance but the illusion of having the knowledge”.

José *Ortega y Gasset* continues: “Let us not be the science barbarians. Science is the greatest achievement of the mankind; but the human life itself is higher as it makes the science possible. In this case the breakage of elementary life conditions can not be made up.” /19/ Today aspirations of many people are sent to Europe though it was noticed by esoteric and exoteric traditions long ago that Europe has no future (O. Spengler, N. Danilevski etc.).

José *Ortega y Gasset* writes: “That is why culture or the life idea system is to be a discipline taught at universities. It is the main task of any university.

Political ideas and actions of the people are poor; their love to women is ridiculous, they bring out-of-date, unhappy and stuffy atmosphere into their homes and it poisons their children forever. They speak out horrible and banal things at a party in a café.

There is no way out: to make your way through the forest of life you are to be cultural, know topography, and have your own routes and methods. That is you are to have an idea of the space and the time where you live and of the modern culture too.

Higher education is, first of all, learning of culture and transfer of the system of mature ideas about the world and man worked out by the previous generations to the new one.

Thus the university education is to fulfill three functions:

- I. Transfer of culture.
- II. Learning of professions.
- III. Research and teaching science to new people.

There **always is a system of life ideas which is the largest height of time, the system which is more modern. The system is culture.**

Culture governs the life and is to be a complete, integral and strictly structuralized system any moment. It is the life plan, the guide through the existence wild forest.

We have to finish with the idle way of education and culture in which they are just decorations which make up grounds for the life of idle people”. /19/ We know which mass media are the most popular: those that **propagandize the so-called pop culture which is entertaining and an antipode of the true culture.** We remember words of A. Hitler about the Slavs destruction: they need only entertaining culture (plus vodka and tobacco) and they will die out without any help.

José Ortega y Gasset emphasizes: “Culture is necessary to life; it is a component of man’s existence like hands are man’s attribute.

Some people have no hand; in this case they are not people, they are handless people. Thus you can also say that the life without culture is handless, unfortunate and false. The man who does not live on the height of his time lives lower than the true life and does all his best to falsify and decieve it.

**Today we are living during the period of horrible vulgarity despite our confident self-satisfaction and appearance.** The average man has never been so low of his time. His existence has never been so false. Practically nobody occupies his place and realizes his true fate. The man deceives himself by tricks thinking of the world to be simple and random.

The researcher who rebelled last century and perverted the faith symbol of the revolt which is now the epoch great deception is to be humanized. **The researcher is to stop being the one he is now – a barbarian who is good at only one subject-matter.** Fortunately, the main figures of the current generation of researchers feel the necessity to add the knowledge on integral culture to their subject matter, and it is because of the inner demands of science itself.

It defines the historical significance of giving the main goal back to universities which is educating of man, imparting culture to him, opening to him the huge modern world in which he is to organize his life to find the authenticity.

**I would like to make the Faculty of Culture the centre of a university and the entire higher education” /19/. DonNTu has made**

some steps and established the faculty in the form of the Institute of Culture of DonNTU /21/.

**The experience of DonNTU in revival of the Institute of Culture.**

The Institute of Culture of DonNTU is the assignee of the University of Culture of DonNTU that has existed since 1959 at the former Donetsk Industrial Institute. R.I. Roitblat, an enthusiast loyal to the ideas of education, was its founder. The Institute of Culture of DonNTU started operating in May 2012. It is aimed at widening of humanitarian knowledge of students and forming of a harmonically developed future engineer. It implements the main function of the university – the cultural one. The staff is grateful to the participants and the administration of DonNTU and the Fate for the chance to work in the name of the lofty education ideals. The Institute would hardly exist without the assistance gained from the lecture centre “The New Thought”, the journal “Delfis” (Moscow), the scientific and philosophical society “The World through Culture” (Yalta) and the staff who carry out classes on a voluntary basis.

There are five trends in the work of the Institute of Culture of DonNTU:

- new trends in science;
- masterpieces of the world painting;
- masterpieces of the world cinema;
- theatre;
- music.

The speakers’ geography is wide. First of all, these are professors of and academics of DonNTU, the culture representatives of Donetsk, Lugansk, Dnepropetrovsk, and Kiev regions. There were speakers from Moscow, St. Petersburg, Novosibirsk, Pskov and other cities. Cultural workers from Germany and Romania requested for making their presentations. If there are some sponsors, the plans can be implemented.

There were 200 meetings during 8 years. We would like to say personal thank you to Prof. V.V. Mirni, V.A. Svyatni, V.P. Kondrakhin, Y.F. Bulgakov, N.P.Rogozin, V.V. Prisedski, V.A. Goltsov, R.A. Dadonov, A.Y. Anoprienko, G.S. Klyagin, E.G. Kureni, D.E. Muza.

The Institute of Culture collaborates with the Museum of DonNTU. The Director of the Museum L.D. Kovalyova has made her presentations at the meetings.

The Institute has also good relationships with the studio “Sophiynist” whose students made the performances at the meetings too. We are also grateful to the Donetski Polytechnic (a newsletter and a video-programme) and the newspaper “Vecherni Donetsk”.

The Institute organizes a publishing activity. The Institute is known not only in Europe but also in the world. The cultural community of the USA proposed us to publish the book of K. Judge “Showing the Way” in Russian. The book was sent to the libraries of not only Ukraine, but Russia, Great Britain, the Netherlands, Poland and other countries.

There were performances of four Russian bards: E.A. Minaev (Moscow), I.N. Plokhov (Pskov), K.N. Yudichev (Vyatka) and A. Zvenigorodski (St. Petersburg) as well as of S. Solyoni (Donetsk), the Zolotukhins brothers (Kiev), M. Romanovski and Echo Radugi (Donetsk), the group “Tochka Tishini” (Donetsk), the group “Aquarium” (Sochi). They were a discovery for Donetsk audience. Besides, there were meetings the subject matter of which was the music of Skryabin, Mozart, Rakhmaninov, Schnittke, Bach, Chopin, and Prokofyev... All the meetings of the Institute of Culture are free. The slogan of DonNTU’s Institute of Culture is “There are only one good, which is knowledge, and only one evil, which is ignorance”. The operation of the Institute of Culture is aimed at eradicating of the ignorance. That is why all the meetings are free. The knowledge obtained here can not be measured.

The new productions of the films “SOS or Synthesis of General Rescue” and “The Outstanding Researchers of Ukraine” (devoted to V.V. Pack) were shown at the meetings.

Poetry: from the student S. Kliman to the professionals E. Baranova, B. Belash, V. Kalinichenko.

Theatre: the studio of DonNTU Sophiynist and the theatre-studio “Pyatoye Koleso”.

Exhibitions: the exhibition of painting reproductions “The Time Link: from Leonardo di Vinci to Nikolai Roerich” and “Man. The Earth. The Universe”. The third exhibition devoted to beauty in its all manifestations is being organized.

There were three competitions of schoolchildren’s compositions “Why Any Country Is to Keep the Culture Treasures”.

Father Nikolai (father superior of the church of St. Seraphim Sarovski) made his presentation on the orthodox photo. The talks of the representatives of clergy of other confessions are always welcome. DonNTU's Institute of Culture is a secular organization and according to its culture position religion is included into the idea equally with science and art. We follow the behest of Patriarch Kirill: "Holy Fathers combined secular scholarship with theology and formed some synthesis. The famous theologian George Florovski called it patristic synthesis. He was dreaming about the new patristic synthesis and wanted the new generation of theologian to couple the outer secular culture with the theological creativity for the latter to be able to fertilize the culture for the words of church to be topical. I pray and hope for the dream of father George to become a reality during our lifetime".

We are trying to implement the dream and our activity is the pray that usually starts with the words: "Sovereign Lord, teach us how I can serve your greatness". /23/

**Conclusions** The highest form of knowledge which is wisdom is the most useful one. "The wisdom of ages is in the words of Jesus: "Thy will be done" /8/. Culture gives the vector of this Supreme will (the evolution, as a matter of fact) development. The truth is its criterion and beauty is its aesthetic expression. The main task of the mankind is not economic but ethic one – the development of the inner man. If the mankind persists in its ignorance in this subject-matter, it will have the fate of Atlantis and Lemuria. Now the mankind has the Gnostic sources which make up the concept of culture: Agni Yoga, The, Theosophy. They propose the keys to understand the culture as a synthesis of religion, science and art. The gnosis (esoteric sources) reads: "The opinion of Teachers about literary creativity in the mankind is of interest. They say that the traditional literature exhausted itself as represented by Tolstoy and Dostoyevski, and the works of a confessionary type as human documents with fixation of different practices in the unity of the range of the entire life" /24/. Thus the gnosis reflects the knowledge new level which is to be assimilated and used in all spheres of application of culture in life. The warning about the possible ruin of culture without which the mankind has no future is symbolic: "People could accept or reject the given parts of the Great Doctrine during the previous millenniums. Now when powerful energies are at their

expense the rejection might cause **the culture destruction**. Atlantics died because of the knowledge abuse. The catastrophe was partial. Today the destruction threatens the entire planet as the mankind which grew in its number is involved into the action orbit. **The problem of the Doctrine acceptance is a matter of life and death for everybody and everything.** Another H-bomb might appear and cause the substance decay the boundaries and sphere of dissemination of which man killers are unable to foresee. Life new forms are to replace the old ones which are obsolete. The war is to be excluded absolutely. The new sky of work, construction and collaboration of all people of Earth is to be over it. Our hand is over the new forms of the life of nations, even if the short-sighted consciousness thinks them to be imperfect. The new country and the new world headed by it will win. New forms of the social and state life will be established on Earth. They will save us. Victims are inevitable. The evolution could never do without victims and death of the forms that it doomed to destruction. Your life view point is to be wider of the wide. The builders of the Great Plan often do not know its grandeur, but Sovereigns do” /25/.

#### References:

1. XII international interdisciplinary conference “Ethics and the Future Science. Scientific Evolutionism. View on the Future. <http://www.delphis.ru/journal/news/xii-mezhdunarodnaya-mezhdistsiplinarnaya-nauchnaya-konferentsiya-etika-i-nauka-budushchego>
2. Caring for the Earth. IUCN/UNEP/WWF, 1991.
3. Goltsova L.F., Alimova R.F., Garkusheva V.A., Goltsov V.A. Scientometric studies of the problem of «Hydrogen Energy and Technology» in the world // Intern. J. Hydrogen Energy. 1990. Vol. 15. P. 655-661.
4. G.N. Golubev. Geocology: Text-book – M.: GEOS, 1999. - 338 p. <http://booksshare.net/index.php?id1=4&category=biol&author=golubevgn&book=1999&page=43>
5. P. F. Belikov. The Family of the Roerich. Spiritual Biography Practice.

- <http://www.roerich.com/zip/belikov.zip>
6. Sides of Agni Yoga. 1953 (part 1) – N.: Algim, 2012. – 704 p.  
[http://www.roerich.com/zip3/grani\\_53\(1\).zip](http://www.roerich.com/zip3/grani_53(1).zip)
  7. Sides of Agni Yoga. 1956. – N.: Algim, 2009. – 640 p.  
<http://www.roerich.com/zip/trismegi.zip>
  8. THE. Book 2. – Mn.: UP Mountain Stars, 2009. – 328 p.  
[http://www.roerich.com/zip3/hram\\_3.zip](http://www.roerich.com/zip3/hram_3.zip)
  9. S.G. Dzhura. To the Problem of Consciousness Multidimensional Nature // The Proceedings of the X interdisciplinary scientific conference “Ethics and the Future Science” – Consciousness as the Space Creative Force. – M.: Delphis, 2011. – p. 30-39.  
<http://grani.agni-age.net/articles12/5035.htm>
  10. L.N.Yasnitski, T.V. Danilevich. Modern Problems of Science. – M.: Binom, 2011. – 294 p.
  11. S.G. Dzhura. Philosophical Approach to the Analysis of Modern Pedagogic (as Applied to Ukraine) // East-European Journal of Advanced Technologies, №4/2(58), 2012. — p.23-27.
  12. A.V. Kendyukhov. The Country of the Hopes that Have not Ever Been Realized.  
[http://kendyuhov.in.ua/index.php?type=full&name=press/press\\_7.htm](http://kendyuhov.in.ua/index.php?type=full&name=press/press_7.htm)
  13. L.M. Gindilis. Consciousness and its Role in the Universe: Scientific, Philosophical and Metascientific Aspects // The Proceedings of the X interdisciplinary scientific conference “Ethics and the Future Science” – Consciousness as the Space Creative Force. – M.: Delphis, 2011. – p. 5-13.
  14. Theory and Practice of Distance Learning. Text-book for university students/ E.S. Polat, M. Y. Bukharkina, M.V. Moiseeva; edited by E.S. Polat. – M.: Publishing Centre Academy, 2004. – 416 p.
  15. D.I. Shapiro. The Virtual Reality and the Problem of Neurocomputing. M.: RFK- Image Lab 2008. – 54-55 p.
  16. G.S. Tesler. New Cybernetics. – K. Logos, 2006. – 2004. – p. 57-58.
  17. L.M. Gindilis. Scientific and Metascientific Knowledge. – M.: Delphis, 2012.



18. E.I. Roerich. Letters. Vol. III (1935). – M.: MCR, 2001.  
[http://www.roerich.com/zip2/ei\\_3.zip](http://www.roerich.com/zip2/ei_3.zip)
19. José Ortega y Gasset. University's Mission. Mn.: BSU, 2005. – 104 p. <http://charko.narod.ru/tekst/ortega/ortega.pdf>
20. F.M. Dostoevski. Demons. M., Pravda, 1990.
21. The Institute of Culture of DonNTU.  
[http://www.roerich.com/n\\_m\\_.htm](http://www.roerich.com/n_m_.htm)
- 21.1. Y.M. Klyuchnikov. Why Does the World Need Heros?  
<http://kluchnikov.roerich.com/kluchn.htm>
22. 47-51.
23. Speech of Patriarch of Moscow and All Russia Kirill in the Kiev-Pecherskaya Laura <http://patriarh.in.ua/uk/node/421>
24. V.A. Afanasyev. Lithuania, My Love, Lithuania //Delphis, №4 (68), 2011.
25. Sides of Agni Yoga. 1954. Novosibirsk. Company Algim. 2011.  
[http://www.roerich.com/zip3/grani\\_54.zip](http://www.roerich.com/zip3/grani_54.zip)

### **6.3. Paradoxes of understanding of the Truth in pedagogic research in the context of the metacivilization**

A.V. Levshov, S.G. Dzhura, V.I. Chursinov, V.V. Yakimishina

*Tendencies of knowledge development in engineering philosophy are analyzed; the perspectives of development of the interaction of a machine and a man are forecasted. The typical examples of man-machine analogues solving of which, according to the authors, have their ontological roots in Gnostic sources are given. The position is argued. The mind balance and its reflection in engineering are discussed.*

«By generous opening of lunatic asylums for supposed the mads people try to convince each other that they are not mad»

E.P. Blavatskaya (Secret Doctrine. v. 1)

«The theory is not crazy enough to be true»

Niels Bohr.

«India might be the real world and the white live in the lunatic asylum built out of their own abstractions”.

B. Jung.

**Introduction** Today, when we are celebrating 700<sup>th</sup> anniversary of St. Sergius, Hegumen of Radonezh, 350<sup>th</sup> anniversary of the Treaty of Pereyaslav, 140<sup>th</sup> anniversary of N. Roerich, 135<sup>th</sup> anniversary of E. Roerich, 100<sup>th</sup> anniversary of S. Roerich and 30<sup>th</sup> anniversary of the Museum of N. Roerich in Izvara, and when known events happened in Novorossia, we would like to share our ideas. The main thought of St. Sergius and the behest of N. Roerich, as the metaknowledge itself, have to do with the future of Russia and the world. We would like to start our research based on observable history and the latest facts. The historical situation in Novorossia that exist at the moment the paper is written can be examined from the point of view of the above prophecies and understanding of historical aspect at the moments of special ordeals.

The authors support the assessment of the situation given in the papers /1, 2/: “I saw the familiar elements of the system approach and large-scale regular occurrences in the doctrines of other civilizations. Then I understood that it did not matter who lived in the lunatic asylums – the whites or Indians. The matter is that the real world is much wider than the basis which the whites, the Indians and the Chinese rest on. To say it figuratively, all live in one lunatic asylum, but in different wards. The real world is much wider than any of the four philosophical systems including the modern one and any separate world outlook rests only on a part of the world complete picture” /1/. Metaknowledge is the sources the author /2/ refers to: Agni Yoga, theosophy, and THE. The thought is proved by the Sides of Agni Yoga:”The universe wisdom can not be inserted into any science, philosophy and religion” /4/. Therefore the explanation of the metasystem which is understood by any dweller of the planet at one and the same time is to be developed. The effort has been made by the author of the work /2/. He chose the system approach formed in the European tradition in the frameworks of the movement to the construction of the general system theory. It was formed under the influence of Chinese philosophy. We think that the metaknowledge is the synthesis Patriarch Kirill dreams about:

“Holy fathers combined secular scholarship with theology and formed a synthesis. The famous theologian archpriest George Florowski called it the patristic synthesis. He wanted the new generation of theologians to learn to combine the subtle culture with the theologian creativity for the latter to be able to fecundate the culture and the words of Church to be topical. I hope and pray for the dream of father George Florowski to become a reality nowadays” /5/. It is the synthesis N. Roerich spoke stating the mankind development stages: “An ignorant man is to become civilized first and then educated; when he is educated, he is refined, then sophistication follows and then understanding of the synthesis which is finished by acceptance of the concept of culture” /3/.

“The line of a struggle between God and devil comes along the hearts of young people. We are living in the culture which got rid of the sin idea which was substituted by the freedom idea. The freedom is the greatest gift of God; people went to barricades, sacrificed their lives and died for its sake. If you ask people, none of them is against of the freedom but the freedom emancipated man and the gift did the man harm”, said the Patriarch.

Nowadays the prophecy of Reverend Anthony the Great came true: “Time will come and people will become mad. Those who will remain rational will be declared crazy because they are not just like others”.

The statements reveal the current situation in the world and in Novorossia. The most important problem now is a pedagogic one as the Roerichs translated the word “man” from Sanskrit as a “perpetual student”.

The pedagogic task of man upbringing is in the Great Law of Analogies which was discussed at the interdisciplinary conference /4/: “The subject-matter is one of the most important for science which always tries to understand the truth about the universe and life. The disclosure of the subject allows forming of the vector of the process of modern understanding which is to rest on the achievements of all set of ancient sciences and on the Great Law of Analogies in particular. This checked synthesis of the past and present knowledge on the world will be resulted in the human evolution which is taking the regular and very difficult exam to enter the necessary stage of the SPIRITUAL development”. Dostoyevski said: “Man is a mystery which is to be revealed. If you do it all life long, do

not say you wasted your time; I am dealing with the mystery because I want to be the man”.

The current world situation makes us think where the world moves to and the place of each of us in the evolution. The analogy method will be used in our work in interpretation which is in The Kibalyon: “Both at the top and at the bottom”. The man and his reflection (thinking as the left-side mechanism) are at the top, and the computer is at the bottom where we will look for analogies and solve contradictions in philosophical aspect on the meta-level. We think that the main principle of culture is based on it. According to Y. Longman /7/ it gives the experience of passed roads and rests on the analogy principle as you can not give the solution for all problems beforehand. But there are the described solutions which can be applied to the real situation.

**Analogies in education.** The analysis /8/ shows that there is a serious technocratic misbalance in education. Unfortunately we only start thinking over the problem though statistics shows its presence on the level of social processes and their results. Thus the USA are training disproportionate number of specialist who are responsible for the rational attitude to the world: 10 humanists and 114 engineers; Germany – 10/39 correspondingly; France – 10/32, Russia – 10/141. The representatives of a humanitarian or ideological block including the leadership of the countries prevail in China, India and Iran /8/.

The idea of the Russian philosopher V.A. Kutyrev is rather interesting in this respect. He speaks about the re-orientation of education from the scientific model to the cultural one. If the first one is the model to program the subject for the narrow set of operations, the second one is to cultivate the personality, its emotional and empathic sides of the spirit. The re-orientation “is important not only to the personality. The uncontrolled development of engineering is the main reason for the mankind’s global crisis. Ecological and anthropological crises are the results of expansion of the rational and artificial and suppression of the being natural forms made by them”. This allows making a conclusion that there is to be the revision of the education current models to eliminate the prevailing unilateralism of training and restore the right of the integral synthetic world outlook (which is the metaknowledge approach). The academician N. Moiseev drove even to the stricter conclusion while analyzing the current (wild) state of the

man: “I am sure that the XXI century is to be the century of humanistic knowledge. The problem of the man able to follow new ideals and, of course, to create them is the most difficult one!” /9/.

*Claude Lévi-Strauss* supports the thesis: “The XXI century will either be the century of humanistic science or it will not exist at all” /10/. We understand that there is nothing higher than gnosis of God’s wisdom and will try to encircle our understanding into the movement landmarks. The metaknowledge reads: “Our goal is to arm the man without any device or apparatus” as he has everything like that in his own microcosm. He can see, hear, feel and smell the phenomena of the Subtle World and subtle energies without the usual earthly devices. The human organism has fiery centres or units and glands which if awoken allows the man see and hear the invisible and the inaudible with his eye and ear. Agni Yoga shows the man the way to master his own spirit device and gives the chance to learn the visible and invisible worlds.”

The thought correlates with that of Prof. A. Minaev, the Rector of DonNTU. He made his speech in front of master’s students and said: “All of you are artists as computer technologies are concerned. But can you use your consciousness and subconsciousness?” When he says this not all academics understand it. He hopes that students do. Now we understand that *Claude Lévi-Strauss* was right when he said: “A scientist is not the person who gives correct answers, he is the person who asks correct questions”. So, the question has been asked and its idea is expressed in the paradox shown in the fig. 1.

**Preliminary remarks** Authors of the paper are not experts in computer technologies and philosophy and there might be a question of how they can speak about it or solve the problem. We support the point of view of the professor of Saint Petersburg University M. A. Basin who wrote in one of his books /11/: “The book is devoted to the mankind in general. It is desirable that the authors are free of the complete knowledge in a separate area of science about man and the society. That is they are to be dilettantes to some extent. However, dilettantism might be a desirable but not sufficient condition for the book writing.” That is dilettantism in some field might be an important advantage as it might be a precondition (but not a guarantee) of the authors’ non-narrow-mindedness and their



Fig. 1. Cover of the record of the Pink Floyd “Delicate Sound of Thunder”.

fresh look. The analogies with the metaknowledge can guarantee the accuracy of their conclusions. There are a sufficient number of the analogies and they are aimed at moving the mankind having a lot of devices and gadgets away from the evolution which is laid down by the Highest Forces.

**The analogies of man-machine** We singled out three important analogies. **The first:** Everybody knows that any computer has the BIOS (Basic Input-Output System) without which it can not operate as it is the first one to be loaded and only then any operating system and all applied programmes are loaded. If there is no BIOS (or if it is broken), it is impossible to load any operating system. We can find the analogy in this sense in Holy Scripture: “The one who has will have some extra; the one who does not have will lose something.” **The second:** There is the concept of emergency in the system theory – the presence of the system special characteristics which are not inherent to its subsystems and blocks and are not equal to the sum of elements which are not connected with each other

by special links which form systems; irreducibility of the system characteristics to the sum of its component characteristics; the synonym is “the system effect”. Here we would like to mention the metaphysics of Aristotle: “The whole is bigger than the sum of its parts”. The Holy Scripture reads: “Where two or three are gathered in my name, I am among them.” **The third:** “Spam (the computer scourge of nowadays) is a technical analogy of the commandment “Thou shalt not take the name of the Lord thy God in vain”...

The traditional ways out of the situation are known but they are, as the saying goes, the work of the devil as “the earthly wisdom is blasphemy in front of God” and the logic of the earthly world is opposite to the highest one. So which way to choose? The answer is in /4/: “Soon science will face the mankind with the fact of the consciousness thin activity and its manifestation in a subtle body and that the sphere of the world which is invisible for a physical eye will be visible with the help of devices. But our goal is to equip the man without any devices. Why do we need them if they are inside any man? But it will be reproduced and double functions of some **centres** not soon. It will take much time and sophisticated and hard work to awaken at least one of them. The fire of **the centre** can be killed and put out at the very moment of its spring if it is not recognized. Ignorant parents killed many of incipient highest abilities of their children. A child trusts his mother and tells her on the things he sees and hears and has an answer: “I do not believe it. It just looks like that but it’s only a fantasy.” Some of them even take the child to an ignorant doctor who drowns the spirit insight in bromide. But science will make us believe in the unquestionable soon” /4/. These ideas of the metaknowledge are proved by modern research.

Let us continue examining the computer technology development.

### **The review of information technology development outlooks**

How will WEB be developed? Different researchers see it like that:

WEB: 0 – text anticipating;

1 –a man gets a text;

2 – the man creates the text;

3 – the community creates the text;

4 – the text creates man;

5 – the text creates the text;

## 6 – why do we need the man then?

The artificial intelligence asserts itself and the statement absurdity dispirits. Fig. 2 shows the evolution of program technologies (history and outlooks):

It causes the question whether the vector of development of information technologies (which is the result of development of the mankind as a whole) was chosen correctly.

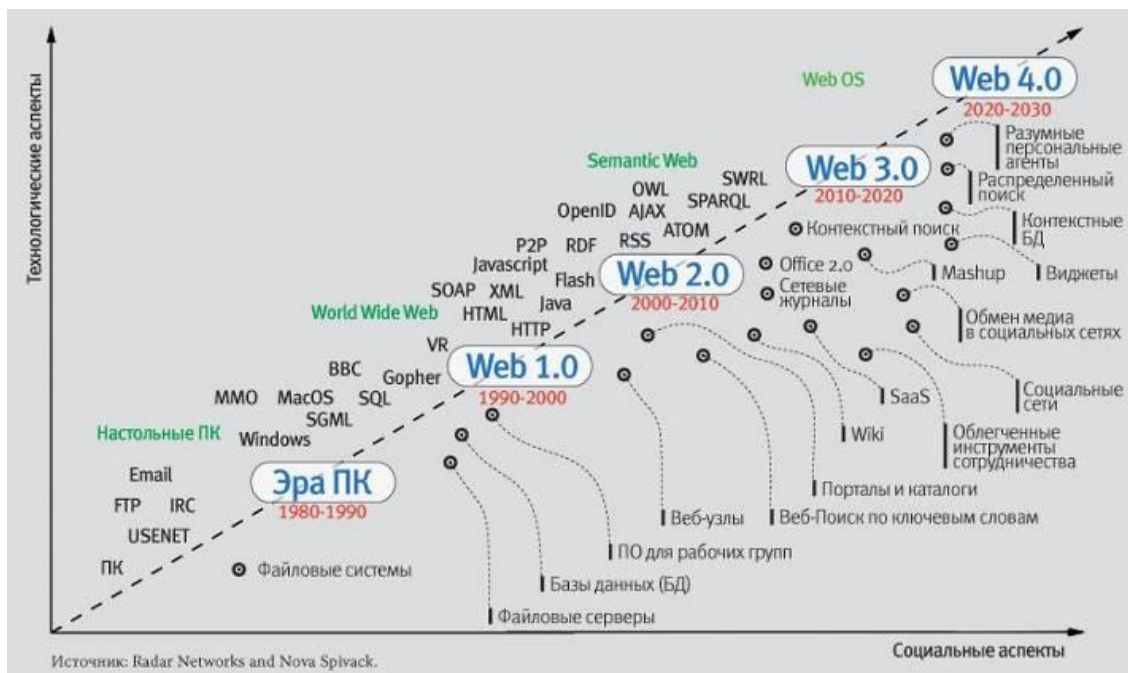

Fig. 2. Program Technology Evolution (History and Outlooks)

The deadlock is present. The metaknowledge is the way out as “the earthly wisdom is blasphemy in front of God” and the logic of the earthly world is opposite to the highest one. The answer can be found in the “Space Legends of the East”: “The spiritual consciousness lagged behind the physical knowledge. Ethics lost its way among formulae. Machines diverted the man from artificial thinking. We have enough of robots now! The world needs a heart as a balance. It is urgent salvation. There will be many people who will replace the most complex devices in the new era. Now robots are being invented, but when the mechanical fever is over, the forces which are inside the man will be paid attention to again. The man



has been always afraid of everything which is mysterious as he forgot that the key to sesame is in him.” /12/

It turns out that, according to the metaknowledge, the mankind is going the wrong way and forecasts of programmers prove it. The development of the man's inner abilities, but not machines, is to be stressed in this case. The following proves it /4/: “The lords show the main direction of the evolution and the lines along which the man's development is to go. Anyone who chose the direction is free to choose the way which is in harmony with the spirit. The directions of the evolution are unboundedness and far worlds' spheres. The means of the evolution are awakening and lighting of **the centres** of the human microcosm and sophistication and perfection of the human device. The goal of the evolution is to equip the man without any device as all of them and more perfect are inside the man. Awareness of the fact will open new ways of searching and possibilities of having new and amazing discoveries. All inventions and devices created by a human genius are in demand until his own device starts operating in its full force. Far planets have no mills and factories, no machines and devices. The life here in its phases is controlled by a creative thought and spiritual energy. Creativity makes everything the man needs for his living”. We can not go further without the help from above: “You can not enter the future without learning. The nearest task is to approve the Life Learning and the best way to do it is to show it on your personal example. The words are not convincing if they are not proved by the personal example that is if the Learning is not applied by the speaker in his life” /5/

**Why metaknowledge?** Forecasts are the science prerogative. But its possibilities are limited. There is not even a chance to give a correct weather forecast for a month. The reason is that not every scientist knows the limits of his competence. The science tools are limited. The Russian encyclopaedist L. Leskov writes: “First, scientists failed to predict any large turn in the world history of the XX century. Secondly, the number of strategic system errors had increased sharply in some countries, in Russia for example. The pay for it appeared to be exorbitant. The scientists did not manage to present the convincing proofs of the wrong strategic solutions to the people making them.” /13/

Different prophets said that robot would be invented and that it would replace the man and form the future army. It is sad as understanding of inventions lags behind them for years and it creates big risks for the mankind existence. The creation of the robot-soldier might not allow understanding of the danger soon and getting into the trap of the terminator created by the mankind. The situation has been played up in many science fiction novels and films.

Tabl. 1 Technical invention forecast

What was forecasted	Year	Author
Computer	1726	J. Swift "Gulliver's Travels"
Rocket, space flights, Moon landing	1867	J. Verne "From the Earth to the Moon"
Robot	1920	Čapek "R.U.R."
Total control over the personality	1920	E. Zamyatin "We"
Total shadowing in the Internet	1949	George Orwell "1984"
E-calculator	1951	A. Azimov "Foundation"
Player	1953	Ray Bradbury "Fahrenheit 451"
Mobile Phone	1953	P. Heinlein "Assignment in Eternity"
Internet, the virtual reality	1960	Stanisław Lem "Summa Technologiae"

### **Computer era paradoxes.**

Computerization has been the main index of the society development up to now. Access to knowledge is one of the main indices of this factor of the society development. However, there are some paradoxes which we see on graph (fig.1).

**The first paradox:** Jean Baudrillard said: "There is more and more information and less and less sense"/14/. It means that the more knowledge (information) we have, the less chance we have to find it at the necessary time. The number of the knowledge grows on one scale and the number of failed retrieval requests –on the other one. Everybody knows that the more things he has at home, the less order is there and the less chance he has to

find the necessary one at the proper time. **The second paradox:** it is shown in the graph: the bigger the total capacity of the world computers is the less benefits it gives to the mankind. The first presentation of the graph took place at the event devoted to the 40<sup>th</sup> anniversary of collaboration of the University of Stuttgart (Germany) and DonNTU (Ukraine). There were no comments then. We support the figurative comparison which says that Pentium 1 computer processor (the beginning of the 80s) corresponds to the total computing capacity of such countries as the USSR and the USA at the moment of the launch of the first Earth satellite. It was at the beginning of the 60s and it is the start of the scale. The minimal computing power is the maximal result for the mankind. Now when every clerk has a computer on his desk and its computing power is million times as much as that of Pentium -1 (and thus the power of such countries as the USA and the USSR at the moment of launching of the first Earth satellite), the clerk uses the computer to type texts, make some easy calculations, communicate in the Internet and play games.

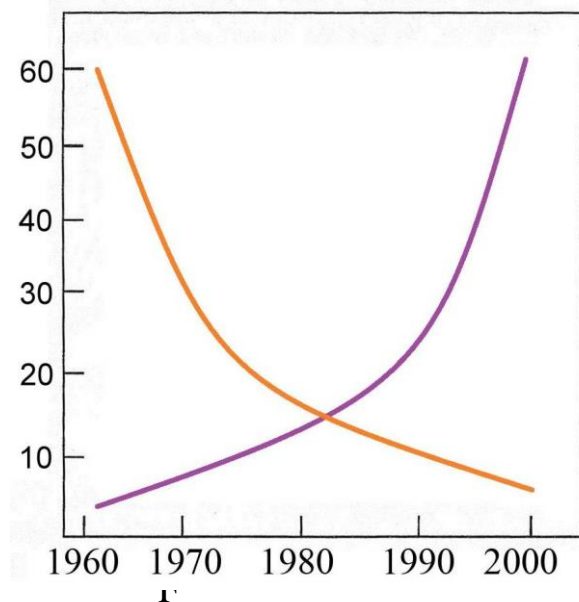

Fig.1 Graph of the growing capacity of computers and reduction of their benefits (paradox).

The demand in this powerful computing system is reduced to the above actions and visual effects are a special place for expenses. Why is it so? The answer is philosophical and ontological – do we want to seem or to be? The question was examined by Erich Seligmann Fromm in details /14/.

**The third aspect of the graph** is represented in the form of the central question of philosophical systems: the correlation of the material and spiritual in the life of man and the society or, in our case, the analogy of the fact that the more material we have, the less spiritual there is and vice versa (in the majority of cases). The strategy of development of the

society and the fate of every person depend on the correct answer to the question. E. Fromm developed the question in his book “To have or to be”. He writes /14/: “The alternative of “possessing and being” contradicts the common sense. Possessing is a normal function of our life: we are to possess in order to live. More than that, we are to possess things to enjoy them. How can the alternative appear in the society the highest goal of which is to possess and to possess as much as possible and in which one person can say about the other “He costs one million dollars”? Things being as they are, the essence of the being seems to be in possession as the man is nobody if he has nothing. That is, according to the graph, the more the income is, the less benefits it brings to the man (in the majority of cases, however, there are some exceptions which are caused by the position of the metaknowledge of “to have but not to think it is yours”).

But still the great Teachers of life assigned the central place for the alternative “possessing or being” in their systems. According to Buddha to reach the highest level of the mankind’s development we are not to wish to have property. Jesus taught us: “The one, who wants to save his soul, will lose it; the one who will lose his soul for the sake of me, will save it. Will there be any benefit for the man in gaining the entire world and ruining himself or doing himself harm?” [Gospel, IX, 24- 25]”.

According to the metaknowledge the lowest man (person) lives by appropriation and the highest triad (immortal) by giving. The scheme is described by the authors in /15/.

**Calculator paradox.** The majority of people think that computer calculates according to a formula and does it correctly, so the computer calculations can be relied on. But the thesis was disproved by «Rump's polinom» /16/ the details of which can be seen in the fig. 2.

The approximation is caused by the machine formats of representation of the real numbers (for example, the formats of the numbers with the floating point) which reflect the endless multitude of the real numbers by the finite set of binary values /17/. Thus if the computer with the finite digit network can not give the exact representation of the real numbers, the result of every complicated calculation has a mistake caused by the error of the output data and interim result rounding. This means that if the approximately rounded values take part in the calculation, the result is approximate too. Besides, the error obtained by calculating superimposes

on the error which occurred while presenting the obtained value in the format with the floating point (the rounding mistake). That is why the accuracy of the result is reduced which is caused by accumulation of the error at each step of every calculation and this leads to absolutely incorrect solving of the computing problem [18].

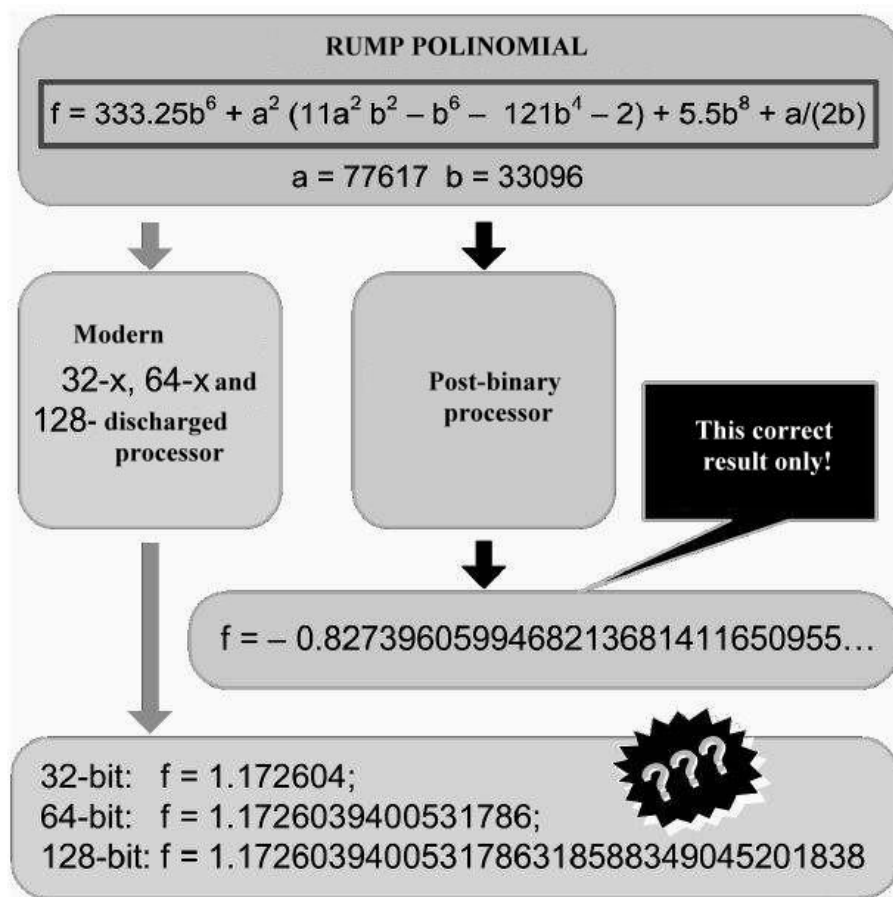

Fig. 2 The paradox of computations «Rump's polynom»

Any real number is represented on the number axis as a single-valued one and in the computer memory approximately.

There are interim ways out but they solve the problems in a global way. Where is the solution? The authors are sure it is in the metaknowledge method.

#### **The essence of the metaknowledge method.**

Esoteric can not give explanations from A to Z like textbooks do. It can only grow accustomed to the problem, understand the universe entire

construction through the synthesis. This leads to the next level of the knowledge and churning of the knowledge space /19/.

It is the art method by its nature which is in the work contemplation and penetration into its idea intuitively. The method causes penetration into the essence of the Secret Doctrine of E. Blavatskaya which proved that the traditional method of learning did not work if the reader was not able to transfer from the logical method to the intuitive one as he would understand nothing because the doctrine text was cryptographed. Many logic lines start in the middle of the text and can go on in the next volume. The one, who will be able to make up his mind to read it, will get the knowledge and the doctrine method, which is important. For the student to get as many benefits as possible, he is to get rid of the habit to think inattentively and in a perfunctory manner, which was brought by the western civilization, and concentrate the mind on the instructions as a whole and on every word which is in them /20/.

The approach corresponds to the thoughts of the outstanding science authorities: “If you do not sin against the mind, you come to nothing” (A. Einstein). P. Kapitsa says: “Agreement between the experiment and the theory is the state of narrow-minded prosperity in science. It closes the development.” /10/

According to the modern encyclopaedist L. Leskov “the construction of the new theory is possible only when we leave the frameworks of the current paradigm” /21/. The author of the paradigm concept T. Kuhn writes that “the normal science is developed in the way as if the nature is being squeezed into the box which has been nailed beforehand. The phenomena for which there is no room in the box are often lost sight of. The scientists working for the normal science do not create new theories and they are intolerant to those who do it” /22/. The situation is like this in parapsychology and theoretical interpretation of the consciousness phenomenon in general. According to T. Kuhn the way out of the situation are revolutionary changes in the paradigm and change of the scientific view point on the world.

The modern theory of scientific experiment cuts off everything, which is in the contrast with the bed of Procrustes of the modern paradigm. It is the so-called the criterion of the confidence interval calculated through the student’s criterion. Everything which corresponds to the criterion under the

repetition (comes to its range +/-) is the confidence interval, everything which does not is to be thrown away as not corresponding to the confidence criterion (!). The paradigm is to be changed. These are the contours of the new methodology.

**New methodology** is based on refusal from the experiment as the main criterion of the truth as entering the nanoworld the researcher influences the result of the experiment by his own thought and biofield. That is why another researcher in another state repeats the experiment and gets another result. The fact that they can not come to agreement is not the result of the experiment (its physical component) but of psychic processes under the experiment carrying out. Everything was all right while the researcher dealt with the macro-and-micro world when the force of the thought could be neglected. But he can not neglect it in the case of the nano-range.

According to classical physics the characteristics of the measured object which are observed under measurement exist before the process and the measurement just eliminates our ignorance in the field; according to quantum physics “the characteristics discovered under the measurement process could not exist at all before it. The reality is created but not just learnt to some extent.” /23/ M. Kaku supports the statement /24/: “The idea of the space consciousness which runs through the Universe is sure to be metascientific. Physics suits the idea, which is important”. The work /15/ builds a bridge between the metascience and classical one. We need to discover the new type of the substance which corresponds to each of 11 dimensions and find formulae (mathematical dependencies among them and the classical substance that is the little part which is known to science). When the natural science tries to check itself with exact sciences a lot of mishaps appear. For example, the Head of the Centre of Methodological Historical and Economic Research of the Institute of Economics Dr. Ananyin, states an interesting fact that when American satellites flew to Mars the method of assessment of probability of life existence on Mars was used, and the result was negative. The researchers decided to use the method to identify the possibility of life existence on Earth. According to the method there is no life on Earth. Thus: no comment. Now we know how to take the results of official science. It requires development which is to be moderate and controllable. It is to be done as the knowledge of the

enemy is to be used (the information war has never been stopped). That is new thoughts are to be accepted at least as a hypothesis under the situation (the traditional science has always been nourished by them, especially in science fiction). The main inventions of nowadays appeared this way.

What is to be the truth criterion? The criteria are given in the metaknowledge.

**The criteria of the super scientific knowledge.**

The requirements to the source of the super scientific knowledge are given in /2/:

1. Its reliability is to be unquestionable.
2. As we speak about the original document that refers to the certain epoch it is to be reflected in the source language: its terms are to correspond to the “scientific” language of the epoch. It is ridiculous to expect the application of the modern differential equations in the source which refers to the epoch of Ancient Egypt.
3. The next question is: how far can the source be ahead of its epoch? If it is too far, it can pass the consciousness of the contemporaries. For this not to happen, the authors of the document should keep to the knowledge accessible to understanding of that period of time.
4. Finally, for us being able to use the criterion of the super scientific knowledge, we are to know the source epoch and the science state of the time very well. We are to know what is affordable and what is beyond the knowledge /6/.

The concept of ancient Indian science on the value of the least linear measure is the example of the knowledge which is beyond the time limits. It is given in the paper /25/. The examples related to Stonehenge are given in the paper /26/. The detailed analysis of the modern sources of the metaknowledge (theosophy, Agni Yoga, The) made by Gindilis /2/ is an important addition to it. It is a collection of more than 50 papers of one author on this subject-matter. Gindilis examines the concept of the Sun in these sources and those of modern physics. They appeared to correspond to the above given criteria. The source says that Earth gets 1/3 of energy from the Sun and 2/3 from meteorites. Calculations of Gindilis prove the supposition which might seem strange at first. This means that the criteria



can be used in the metaknowledge and thus in metapedagogic as the mankind got the knowledge with its help in all known (and unknown) centuries. The fact is mentioned in energy and information pedagogic /27/. The evolution pedagogic says the same.

A very interesting classical conference “Artificial Intelligence: Philosophy, Methodology, Innovations”/28/ has been held in Moscow. The presentation “Neural Network Technologies as a Method of Getting of New Knowledge” made by Prof. L. Yasnitski (Perm, Russia) was of interest and followed by heated discussions. He summarized the Perm practice of creation and application of intellectual systems in industry, economics, sociology, ecology, political science, medicine and criminalistics. The facts of discovery of new not known previously scientific and engineering knowledge made by the neural networks were mentioned. It provided higher accuracy of diagnostics, prognostication and optimization of modeled phenomena and processes. The speaker emphasized that some of the knowledge discovered by the method was recognized by the scientific community at once (for example, the project E-Aesculapius in medicine). Some new laws managed to be explained materialistically only after long discussions with experts; and some of them still can not be explained in the frameworks of the traditional scientific theories. After the presentation discussion the wish “not to mix the official science with esoteric” was spoken out. However the majority of speakers agreed that the “modern scientific world had become less orthodox” and new knowledge and facts even though they are beyond the frameworks of generally accepted scientific concepts are to be published as “the subject-matter for discussions” the more so because their application under the development and implementation of the intellectual systems allows getting of more significant practical results. There was even a slogan: “We ask you not to take our results seriously as astrology is in the black list of struggle with pseudo-science issued by the General Committee of the Russian Academy of Science”. Here we should say that many lances were broken over the subject-matter /28/.

**Pedagogic analogies** Sergey Rukshin, a mathematician and a supervisor of G. Perelman wrote in his article “We will not have the Lomonosov any More” that he did not think much of the new concept of the education reform and the activity like this. Instead of looking back and

summing up of the reform results we try to avoid analyzing of the real problems and formulate new slogans. We are to understand which education our country needs and identify the fundamental core of the school course in interrelation of mathematics with physics, chemistry, biology and other disciplines. The content of mathematical education is to be based on the fundamental core and defined from school and up to researcher training. The academician A. Semenov who is the head of the concept developers inserted everything which is possible from the point of view of his hobbies, obtained grants, business etc. into it. He made an exaggerated emphasis on usage of computers, distance learning, e-books and resources that is on everything which the business of the President of the Publishing House “Prosveshchenie” A. Kondakov and his wife was based on. The computer is an instrument and it is to be used. Nobody has organized training courses on a hammer usage. Every person used it as it needed: a surgeon and neuropathologist knocked it on a patient’s knee; a carpenter used it to nail. Thus the concept is full of harmful things which distract people from the informative role of mathematical education. The immediate task of mathematical education is to develop thinking. He has been dealing with education for 38 years and is the only pedagogue who brought up two Fields Medal winners and whose students won 90 medals at international contests. So he understands something in the subject matter... He hopes that the concept will not affect the education. The generation of pedagogues who got used to work well will go on doing it well. But the concept threatens the future pedagogic as it is dangerous even by its existence. We take the idea of an “outstanding pedagogue” in a wrong way. Today to be certified a teacher is to write scientific papers, participate in conferences and have students-winners of different contests. The latter is, by the way, the task of additional education (circles and optional classes). The task of the teacher is to teach. There is a class of Russian at school in the suburbs. A half of pupils in class are children of migrants. Some of them have only started to learn Russian from scratch. If a teacher teaches them to communicate in Russian, appreciate it and shows them how to behave in the cultural environment it will be a great achievement. It would be more important than writing scientific papers and attending of the conferences. The great teachers will not be touched as they bring gold eggs the heads of the regional education boards boast of in their reports. The

best teacher won't be touched in a small town and the fact of his being a private tutor will be ignored as he teaches children of bosses. But for the great teachers to grow the young ones are not to be touched. They are to have conditions encouraging them. There was a remarkable effect in 1990s: teachers did not get salaries but their hands were not tied. So many wonderful teaching initiatives were born then because there was no formal reporting. You are paid a little but we do not prevent you from working. Now the teachers are paid a little, but their hands are tied. It is a well known fact that the modern youth are worse than the previous generations. Children were changed for worse. First, they have a clip consciousness. My students lose logic links within 2.5 - 3 minutes and thus are unable to learn something. So they can be taught to make mechanical differentiation but not to develop their thinking. Mathematics is the only discipline which is professionally aimed at developing brain through the problem solving. School is a dump of formulae and recipes for problem solving now. Students solve a quadratic equation for a month and learn a formula by heart. The student's motivation was changed sharply. For many of them leaning is not the means to get a profession and education; it is that of getting a sheepskin which will help them to earn more.

Children have a very poor memory. Because of the yells of idiots that the children are overloaded they have less and less responsibilities at school. Latin and Greek were taught at grammar schools earlier. There were such disciplines as pray and Gospel learning at parish schools. Why? The answer is to train children's memory.

Besides, the children's infantilism is high. I can show you a letter of explanation written by one of my students: "I do not do my home tasks on mathematical analysis because I come back home late and do not have time to do it by morning. At night I either have a rest or do something else". Do you like it? And you say that I am a merciless critic. I have proved I was a successful pedagogue, though I had been prevented from doing my job for many years. Even now the university's Rector or lyceum's Director would not be pleased to have a pedagogue who argues the opinion of the Ministry. In this case it is not important that the pedagogic work is successful. One of our teachers who are close to the leadership of the Education Committee tells me: "How dare you argue the opinion of the Ministry!" How dare I? Someone is to. My career (scientific and official) was not successful

because of it. So if I have a chance to speak I am going to do it. I like the country but I do not like the state which disorganized education and science. However, I can not separate myself from what is going on in the country and in the state... We should spend our spiritual forces on children and it is impossible to do it according to official instructions. Hardly ever one of us would like to take our child to a doctor who bought his degree diploma and who has no time to examine the patient because he has his private clients. Why does our government want their children to be taught by awful teachers then? Rich people send their children to study abroad, though the level of teaching at schools is lower there. We should stop having illusions about total secondary education. Our schools are not social institutes like it is in the USA. One American pedagogue told me: "If you would like to know when and where your child will have his first experience in alcohol, drugs, cigarettes and sex, it is sure be at school. But it won't have education there". Russia is not a rich country and we can't afford ourselves to have schools which are social institutes.

It is a crime against your country to position education as a service. A pedagogue is not a slag. Education is a system forming national institute which we are losing. It is the stupidity that threatens the national security when the second person in the country does not know what is going on in education. The Prime-Minister says he has never met the teacher who was not satisfied with the Uniform State Examination. His milieu is likely to demonstrate fake veneers to him instead of informing on the real state of affairs in the country. The reforms are impossible to be implemented without being aware of the real situation.

He likes the only fact that despite the reforms pedagogues and educational institutions are going on working. But this takes place not due to the reforms but against them ...

**Preliminary conclusions.** The ideas presented in the paper prove the thought of A. Vladimirov that "the scientific and spiritual revolution that liberates the mankind from the total technocratic dependence and gives the true leading place on the planet and sense of the human being back to the man is to replace the scientific and technical revolution" /29/.

The future union of Russia, Ukraine and Belarus (according to the behest of St. Sergius) will take the atheistic curb off science and reveal new dimensions, discover new metals and spatial energy. Russia (and Ukraine

as its part) is to demonstrate a new spiritual culture, new all-triumphant beauty and harmony between the spirit and the body. Russia is to demonstrate the union of religions based on the reality and many-sided overground being, to consolidate the mankind's spiritual energy on Hierarchy. Russia is to build a bridge for the constructive collaboration between the mankind and far worlds. Finally, for the miracle of the new possibilities to be a reality Russia is to be the core for the future planetary community and Roerich organizations are to be ahead of the New World and its discoverer. Friends, unite for the building of the New World! /26/.

The second: information has become not only the creative but also the destructive phenomenon nowadays. Where is the boundary of the trouble caused by the great mind? Where does the information become harmless and change its sign into the negative one? Plato used to think the town where 5040 **citizens** live to be **the ideal**. That is there is an optimal inhabitant number. We think we should talk on the optimal amount of the information too. Then it is useful. S.Lem wrote a book "Technology Sum" in which one of the chapters is called "The Megabit Bomb" /30/. Isn't the Internet such a megabit bomb? We see the criterion in the metaknowledge which is given in the book "Heart". Only heart development of each person will say where the boundary is. The inner man is to be developed and the entire message of the metaknowledge is aimed at it /4/: "Our goal is to equip the man without any device as all the devices in their potential are in the human microcosm. The process of the **centre** opening and sophistication of perception is safe only under the complete cleaning of the consciousness from garbage. Otherwise the mankind's death is inevitable. If the consciousness lags behind, scientific discoveries are dangerous. They threaten people by mutual destruction. That is why the consciousness transformation is the most important and urgent task. The task is extremely difficult. It is easier to move a mountain than to awake the petrified consciousness. The state of the consciousness depends on the heart. To awaken the spirit we are to knock at the human hearts. Crowds are to wake up and put their veto upon the governors who start wars. There won't be Peace on the planet if the nations do not help do it. It will be established against the will of the governments that lead the mankind to death. The world situation is that of tension to the highest degree."

Third: we totally agree with the words of A. Einstein: “I am afraid that the day when technologies will excel an ordinary human communication is sure to come. Then the world will have the generation of idiots”... We think that the metaknowledge shows the way out. It will take not one life to learn it. We spoke about it at the previous conference.

#### References:

1. S.I. Sukhonos. Metacivilization. – M.: Book on Demand, 2011. – 448 p.
2. L.M. Gindilis. Scientific and Meta Scientific Knowledge. – M.: Delphis, 2012. – 576 p.
3. E.I. Roerich. Letters. 1929-1938, v. 1.- Novosibirsk: 1992. - 29.05.31
4. Sides of Agni Yoga. 1970. – N. Algim, 2008. – 560 p.
5. Speech of Patriarch of Moscow and All Russia Kirill in t he Kiev-Pecherskaya Laura <http://patriarh.in.ua/uk/node/421>
6. XIII international interdisciplinary conference “Ethic and the Future Science” “Analogy World is the World Prototype”. <http://www.delphis.ru/journal/news/xiii-mezhdunarodnaya-mezhdistsiplinarnaya-nauchnaya-konferentsiya-etika-i-nauka-budushc>
7. Y. Lotman. Art Gives the Practice of What Has Not Happened. Talks about Russian Culture. <http://2002.novayagazeta.ru/nomer/2002/15n/n15n-s11.shtml>
8. D. E. Muza. Globalistic: textbook. – Donetsk: Knowledge, 2012. – 310 p.
9. N. N. Moiseev. Fate of the Civilization. The Way of Mind. – M.: Slavic Culture Languages, 2000. – p. 102.
- 10.N.S. Avtonomova. Claude Lévi-Strauss in memoriam: lessons of structural anthropology and humanism of the XXI century // Philosophical Aspects. [http://vphil.ru/index.php?option=com\\_content&task=view&id=191&Itemid=52](http://vphil.ru/index.php?option=com_content&task=view&id=191&Itemid=52)
- 11.M.A. Basin, G. I. Basina. Synergy. The Evolution and Human Rhythms. <http://314159.ru/basin/basin100.htm>

12. S.V. Stulginski. Space Legends of East. [http://www.roerich.com/zip/kosm\\_leg.zip](http://www.roerich.com/zip/kosm_leg.zip)
13. L. V. Leskov. The Non-linear Universe: A New Home for the Mankind. – M.: Economics, 2003. – 446 p.
14. E. Fromm. To Have or to Be? – M.: ACT, 2000. – 365 p. / [http://lib.ru/PSIHO/FROMM/haveorbe.txt\\_with-big-pictures.html#toc00001](http://lib.ru/PSIHO/FROMM/haveorbe.txt_with-big-pictures.html#toc00001)
15. S.G. Dzhura. To the Problem of Multidimensional Consciousness// Proceedings of the X interdisciplinary scientific conference “Ethic and the Future Science” – Consciousness and a Creative Power of the Space. – M.: Delphis, 2011. – p. 30-39. <http://grani.agnia-age.net/articles12/5035.htm>
16. Eugene Loh, G. William Walster. Rump's Example Revisited. <http://link.springer.com/article/10.1023%2FA%3A1015569431383#page-1>
17. J. Foley. Encyclopedia of Signs and Symbols. \_ M. Veche, ACT, 1996. – 432 p.
18. A. Y. Anoprienko. Post binary Computing and Interval Calculations in the Context of the Code and Logic Evolution. – Donetsk: DonNTU, UNITECH, 2011. – 248 p.
19. A. Vladimirov. The Modern Movement of Roerich. – M.: Belovodie, 2013. – 100 p.
20. E. Blavatskaya. Instructions for the Students of the Inner Group. M.: The Spiritual Literature Publishing House; Sphere, 2000. – 592.
21. L.V. Leskov. Five Steps behind the Horizon. – M.: Economics, 2003. – 262 p.
22. T. Kuhn. The Scientific Revolution Structure. – M.: 2001.
23. B.N. Menski. Concept of Consciousness in the Context of Quantum Mechanics // Success of Physical Science, 2005. Vol. 175, №4. – c. 413-435.
24. M. Kaku. Physics of the Future. – M.: Non-Fiction, 2012. – 584 p.
25. Javāharlāl Nehrū. Discovery of India.- M.: Foreign Literature, 1955. – 434 p.
26. A.A. Grobovski. Mysteries of Ancient History. –M.: Knowledge, 1971. – 534 p.

27. I.P. Podlasi. Energy and Information Pedagogic. – M.: Data Square, 2010. – 424 p. <http://www.roerich.com/zip3/energoenergy.zip>
28. Conference “Artificial Intelligence: Philosophy, Methodology, Innovations.” <http://www.scmaiconf.ru/matireals.php>
29. A. Vladimirov. The Modern Movement of Roerich. – M.: Belovodie, 2013. – 100 p.
30. S. Lem. Technology Sum. – Minsk, ACT, 2002. – 668 p.

## **7. Cultural integration of the future Europe**

### **7.1 Ukrainian idea as an element of the Russian idea in the context of the universal values**

**S. G. Dzhura (DonNTU, Donetsk, Ukraine)**

**The idea of the country is not what it thinks about itself,  
but what God thinks about it in Eternity.**

**VI. Solovyov**

*This paper makes an attempt to look at the Ukrainian national idea from the point of view of universal values and evolution development of the mankind. According to the author the main place is occupied by the Russian idea at the modern stage of the mankind's development and the future Russia which has a room for Belarus and Kiev Rus- Ukraine is meant.*

**Preliminary remarks.** I started writing the paper in order to know this difficult issue. It tried to do my best to emphasize the scientific aspect and keep away from politics. But I did not always manage to do it as the topic is too burning. E. Roerich said: “Somebody told once that only experts could know and carry on country's policy. One clever man objected: “The problem is that it is impossible to define where the policy boundaries start and finish. Every citizen of a country makes the policy voluntarily or not. That is why the best measure to improve any policy is to start with correct



upbringing and education of the nation in the spirit of friendship and limitless cognition”.

**Introduction to the problem.** Ukraine gave rise to many questions during its independence. The main one is the absence of the formulated national idea. It is the matter of many research projects which is to be done by the community of scientists such as the institute of strategic research. That is why the paper will not propose the final solution for the problem. It only shows the future ways of solving and deadlock directions. The author addressed the Institute of Strategic Research of Ukraine and the mass media with the proposal to discuss the problem /1/ but did not get any interested reply.

**The problem of national identity of the Ukrainians.** The people of Ukraine face the problem of searching of the national identity. It is not new for many nations. DonNTU has published a book on search of the national identity of the Germans /2/. It is a long and sometimes distressful way. The Ukrainians are solving the analogous problem and their path is also thorny. The national idea of Ukraine depends on the problem solving.

**Analysis of the current information field shows** that the problem of the national idea is topical today but the thoughts about it look more like The Lamentations of Yaroslavna but not like the constructive dialogue which can offer Ukraine the new reference point. What does the nationwide idea mean and is it to be based on the title nation nationalism, patriotism or the Messianic goal?

Nowadays the national idea is identified with the idea of the Ukrainian nation. The idea of the “Ukrainian nation” is understood not as “the people living in Ukraine” but as the “Ukrainians”. It was reflected in one of the slogans of the election campaign “Ukraine for the Ukrainians”. It sounds anxious practically as Germany for the Germans etc. That is it is not the national but the nationalist idea that has failed many times in history...

The existence of Ukraine as a state arises many questions and problems. The policy of the “orange” political elite leads the state to a crisis. The stable Ukraine can exist as a polyethnic state in which the rights and freedoms of all the nations are respected. But the political course has a different direction... The national problem is a very dangerous one. It is the boomerang that will cut off the head of the politician who will launch it.

There is an impression that this has already been done. It is, to put it mildly, short-sighted to build the stability on nationalism.

Can the national idea be built on the interest of one ethnos only? Will it be vigorous if it does not take into account the interests of other people? Will the multi-national country be able to preserve its territorial integrity then?

The national idea is not an assortment of historical symbols and social benefits in a national packing but the general goal and the long-term strategy of the society development. For the goal to be really general and the desire to follow it despite possible victims to be passed from generation to generation there should be some obligatory conditions.

According to the authors /3/ the national idea will be creative if it is:

— first of all, transnational, transsocial, transterritorial that is equally attractive for the absolute majority of the population of the country despite the nationality, social status and place of living;

— secondly, based on the system of the national values and priorities, historical practice of victories and achievements but not on defeats and national humiliation;

— thirdly, to correspond to the spiritual and material interests of the modern society.

The challenge from **the national idea of the ethnic character** is the serious challenge to new history, the mankind and all world religions. The mankind managed to overcome the challenge of racism and the national exceptionality last century. It was done at the cost of huge victims. The witnesses of the hell on Earth asked the question: where was God when ovens of concentration camps were burning and an act of genocide was committed over many nations that were thought as politically disloyal and ethnically defective? However, national wars often related to the religious factors and ethnic cleanouts are still going on. The collapse of multinational states and appearance of the national ones will challenge the mankind, the main human rights, state security, stability and the universe integrity in the XXI century too /3/.

Religious and national factors are inextricably intertwined in the real life. The factor of nationalism raises very burning questions in front of all the world religions. Even the religions that advocate justice, peace and

conciliation often support some radical parties, one nation and take the mission of forming the nation or state construction.

The author sees the way out in the national approach – synthetic philosophy of East and cross-cultural synthesis of Agni Yoga. The approach was argued at some international conferences and the paper /4/.

Thus Ukraine could not avoid the challenge of the national factor which appeared to be inextricably intertwined with the religious one. As a result the main national interests of none of the nations and nationalities of Ukraine including the so called titled one – the Ukrainian - were satisfied. From the other hand rather democratic laws of Ukraine on freedom of conscience and religious organizations were unable to resist anti-democratic state methods of solving church problems because of the narrow political interests tinged with nationalism.

The nationalism functioned as a new “state and national” religion during the first years of independence. Its myths were the national history and the history of Ukraine was rewritten but remained as ideologized, tendentious and burdened with myths as it was in previous centuries.

Economically self-governed Ukrainian Orthodox Church was interpreted as Russian church dependent in church and political problems on Moscow. The then president of Ukraine stated that church in the independent state was to be independent on external religious and political centres. The Verkhovna Rada adopted a decree which has not been cancelled so far. It concerned incompetence of election of Metropolitan of Kiev and All Russia Vladimir Primate of the Ukrainian Orthodox Church. Thus the self-declared Kiev patriarchate was legalized as the national state church. The nationalism and political lawlessness in church caused a profound, painful and long-term schism of Orthodoxy in Ukraine.

There are 22.1% of ethnic Russians in Ukraine. The Ukrainian-Russian relationships in Ukraine are of a specific character. Many ethnic Ukrainians identify themselves with Russian culture and this is not in contrast with their ethnic origin.

This should be taken into account in Ukraine. 41% of residents of Kiev were against of obligatory introduction of the Ukrainian in the system of education after it had been declared the state language. 7.1% of Polish Greek-Catholics of Lviv eparchy who can not be suspected of being “Moscow agents of influence” called the Russian their native tongue /3/.

However, the Russians, the Ukrainians, and the Polish are citizens of Ukraine the legislation of which excludes their discrimination according to nationality or religion.

Why did the Orthodox Christians of Ukraine fail to at least minimize the destructive ethnic potential? The role of the nationalism was one of the decisive in the events. Why did the national feeling of those who call themselves the Christians force the essence of the doctrine of Christ on what is primary loyalty to Christ or the national identity? There is the definite answer to the question which is in the spiritual plane. The current split of the orthodox believers in Ukraine is the witness of a serious defeat of the nationalism /3/.

However Gospel differentiates what belongs to God and what to Caesar. Even when church had to play the role of the main social institution the mission made it being kept away and overcome different problems for the sake of being kept away.

The history of Church indicates that the dialogue between Church and the society was a disputed case as a rule. The society is sure to have accumulated a lot of positive values which Church recognized and learnt. However, there is also the “spirit of this world” in it. Unchangeable external challenges will be accompanied by the internal ones in the bosom of the Church. The challenge of **nationalism, both external and internal**, is one of them. That is why the problem of the essence of the Christian patriotism is topical today.

According to the spiritual and patriotic union the current situation could be described as the “betrayal being the national idea of Ukraine” /5/. They give the following arguments: “Formation of the “national ideology” of the modern Ukraine is taking place on the historical example of betrayers, killers and traitors out of whom the “oranges” form the pantheon of their heroes”. According to M. Zadornov “While moving from socialism to capitalism we took the worst things from the capitalism and left the best ones in socialism”. It is sad. The point of view of S. Gorokh /6/ who thinks “the national idea of Ukraine is harmony” is opposite. It is the point of view of the All-Ukrainian Analytical and Research Centre “Rodove Dzerelo” of family ecoselements which is not connected with the official opinion which the clerks are implementing so actively and which is called Ukrainization. The language is known to be the means of expression of any

idea and it can not be the idea itself. The idea can be expressed in different languages and it will not cause its change.

**So, the national idea is an open agreement between a citizen and a state on mutual obligations and guarantees, principles of a personal and social life, the ethic platform which allows the person to associate himself with the certain nation, be proud of the belonging and pass the feeling by right of succession.**

**The formulated national idea is to fulfill the function of a memorandum in which goals are stated, mechanisms of their achievement are stipulated and guarantees are given to all the participants of the integration process.**

**The false national idea is sure to be devaluated and require more and more means for its provision up to the complete bankruptcy. The state bankruptcy is always followed by an economic collapse of the state.**

The national democratic idea is a visa for Ukraine which is longing for the European Union. The details of this are still not known. That is there is no official point of view on the process. The country looks like a plane that is flying to nowhere. The passengers have to guess what the crew will decide during the flight (the crew wants to be in the NATO, but the majority of the passengers have the opposite opinion). People are worried because of the situation of the unsettled vector. The thesis of transatlantic integration is beneath criticism as there has been no referendum and this is only the point of view of some state figures that express the opinion of the countries due to which they got their posts. Here we would like to mention the first version of the review on the grand betrayal of the nations living in Ukraine. According to Pavel Florenski “the country which does not serve the truth and does not take care of the benefits of its citizens is known to be doomed.”

The film “The Undeclared War” /7/ is not on in the country of the triumphant democracy, and it is symptomatic. According to the authors of the film the war has started on our territory and it is being fought against any rules. The issue is suppressed by all the mass media in Ukraine. There had been no promised welfare after Hungary, Poland, and Baltic countries entered the EU. Economics, the social sphere, education, healthcare of the countries were broken. The same is taking place in Ukraine. Russia is next

in turn. Famous politicians, deputies and public figures speak of the successful operation called the “orange revolution”. The political elite of Ukraine did not ask the opinion of the people and defined the European way of development. Now it is exporting the orange revolution to the territory of Belarus and Russia.

Some words about the political elite of Ukraine. The advisor of the previous President of Ukraine made a speech on TV. His words were literally like that: “There is no political elite in its high meaning in Ukraine”. The elite are to be formed and brought up. That is why the elite of Ukraine are the communities about which the French philosopher J. Renan wrote “The nation is the community which is united by the false assessment of the past and hatred towards the neighbours” /8/... We recollect the famous thesis that history teaches nothing...

One of the central Ukrainian newspapers “The Week’s Mirror” states the fact of the absence of the national idea. The author of the summary /9/ offers doing a research on interests and values of different society layers and make a transition to the adequate definition of the Ukrainian national idea on its basis” /9/. Here is a question: Is there any solution of this sacramental question? Prof. D. Bondarenko from St. Petersburg gave an answer /10/. There are two epigraphs to his paper: “The Ukrainian problem appears in the political sky of Europe any time there is a crucial moment for Russia” /11/. “We are living at a wonderful period when artificial states, people and languages are being created.”/12. / The author accentuates that “the Ukrainian idea can not be explained rationally. Let us compare the desire of the USA for freedom in 1770 and that of Ukraine for independence in 1990. The desire of North American colonies for independence was formulated in the paper of T. Paine “Common Sense” in which he says that the independence is necessary to create better social and economic conditions. As to the Ukrainian version the independence is the unexplained end in itself which requires human resource submission and does not guarantee better social conditions. The modern Ukrainian statehood is advantageous for officials and is absolutely disadvantageous for the nation to which it brings hardship only. The Ukrainian national idea is being exploited by the machinery of state that is afraid of losing of the well-paying job” /10/. Then the author examines the arguments of M. Grushevski who suggested the idea of “conciliar independent Ukraine from

the Kuban to the Carpathians” instead of that of “great integrated and indivisible Russia” /12/ with I. Linnichenko /13/. He also examined the origin of Ukrainian separatism /14/. The Ukrainian vector of independence was formulated by M. Grushevski whose papers according to A. Storozhenko are full of hatred to Russia and even to the words “Rus” and “Russian” and to the power. He proposed the cult of the revolution instead and unusual liking to the foreign conquest of Russia.

As to the terms of Ukraine or Rus Earl A. Volkonski who lived in emigration argued with representatives of Ukrainian movement trying to prove the artificial nature of the term Ukraine as according to the historical documents, both Russian and Western European, of the X-XX centuries the territory was called Russian, Rus or Rus Minor and the term of “ukraine” was written with a small letter and was used in the meaning of outskirts. However, the later one was introduced to people due to the “Bolsheviks” and their policy of “ukrainization”.

The book “The Ukrainian Problem” came out in St. Petersburg in 1914. It is quite an interesting source not only due to the main issues of adherence to everything related to Ukraine but due to accusation on the part of Russian patriotic community. The book quotes M. Yuzefovich and P. Stolypin that demonstrate that “the movement has no roots in the mass” and that they “assist in renewal of the Ukrainian separatist movement under the pretence of cultural and educative goals.” The book offers the opinion of P. Struve who condemned the Ukrainian movement for its attempt to break the ethnographic integrity of the Russian nationality and bifurcate Russian culture. The term “to bifurcate” proves that there was no movement like this in Belarus. He blamed the Ukrainian movement of being an Austrian, Polish and German intrigue against Russia.

I. Linnichenko pointed out that independence was advantageous for a small part of the Ukrainian elite that had a chance to exploit people uncontrolledly. He also spoke on the danger of the separatism during the war period as it served the purpose of the enemies of Russia. The reasons of the separatism, the desire to be away of the common history, “Russian body” and “Russian case” were not clear. The separatists had to prove the Ukrainians that they were a separate nation and they were to establish a separate state. It is symptomatic that M. Grushevski did not reply on the

open letter. He is likely not to have had the answer and not to have understood why he needed it. He just obeyed the Austrian order /9/.

Linnichenko continued the discussion in the papers “The Ukrainian Separatism” and “Has the Original Russian Culture Ever Existed?” in 1919. The author says that Russian culture and the Russian language are common for the three branches of East- Slavonic peoples and we have no reason to speak about the separatism when the matter concerns the original culture preservation.

The representatives of the Russian pre-revolutionary and emigrant historiography proved that the Ukrainian separatism was the artificial intrigue of Austrian and German ruling groups in their struggle with Russia. According to M. Smolin “anti-Russian Rus” changed many masters in the XX century. They were the Austrians, the Germans and the Americans, but there was only one goal of its existence: to break up the Russian nation.”

The Ukrainian separatism was not supported by the mass in Ukraine and, according to N. Ryazanovski, was widely spread among the Ukrainian intellectuals of Austrian Galicia. R. Service thinks it is connected with anarchic mood of Ukrainian peasants who were thought as the expected support of the nationalists and for whom the problem of the land property was the main one.

The Ukrainian separatists compensated the lack of support from the own people buy the foreign military and political interference. It was during I and II world wars and it is going on now”/10/.

**So, we can drive to the conclusion that the Ukrainian national idea or the Ukrainian separatism is none other than the social utopia, the fantasy of a part of Ukrainian intellectuals which has nothing to do with the true national interests and self-determination. We can speak about the Ukrainian idea in the context of the Russian one and the universal values only.**

**The necessity to be based on the knowledge of the principally new character** The knowledge of the XXI century, which is that of globalization, is sure to have a new character /8/. The authors from St. Petersburg spoke about it /17/.

There is the knowledge which can be useful for all the people or the majority of them. The knowledge can be considered that of the mankind. As



all the people are interested in it they are to be organized to solve the following problems:

1. To provide free access to the knowledge for all the people. Books (libraries) newspapers, the radio and TV, leaflets, the Internet and Synergonet are the means to increase the survival potential of some people and of the mankind which is the complicated self-organized system.

Any man-made structure that impedes the dissemination of the knowledge by force and financial limitations worsens the future of the mankind and of its separate quants and is criminal from the point of view of the mankind. The idea can be the criterion of criminality and totalitariness of regimes despite they think themselves to be democratic. The main criterion of the power criminality is not only the number of people killed by it but the amount of the knowledge to which all the members of the society do not have *free* access.

2. To provide the people who take part in getting and dissemination of the knowledge necessary to the mankind for survival as a single wave with deserved existence. Here the problem of existence of researchers, pedagogues, journalists, representatives of culture and religious figures arises /17/.

I think the Ukrainian national idea coincides with the Russian national idea and belongs to the knowledge of the mankind. The conference has a chance to give the free knowledge to people. The Ukrainian (Russian) national idea is closely related to the vector of development of the entire mankind.

**The crusade against culture** and the present misrepresentation of the vector of the mankind's development and substitution of values are known. Russia (Ukraine) has always had serious enemies who did not need the Russian (Ukrainian) national idea. They needed the territory the population of which is united by football, box, beer and mobile operator brands only.

The population for which the most important thing is a full stomach and the latest mobile phone, the spiritual and cultural need of which is narrow and the morale of which is flexible are petty slaves who have no own values, live on tips and wait for circuses.

The substitution of the national idea by the short-term and middle-term goals of improvement of the welfare of the citizens and economical

competence is like the substitution of the house basement by door latches. It is the result of the strategic blindness of the modern and so-called “ruling elite” /18/.

**The question “Who is guilty?” is a rhetorical one in this context. Then the next eternal question arises: “What to do?” Let us try to find the answer. As the world is undergoing the transition from one paradigm to another (from one scientific world outlook to another) the author /4/ gave grounds for the importance of the paradigm change and the change of the syntagma which is the strategic view on the world. The mankind faces the danger of finishing of its existence as a species (all crisis types speak about it). The only correct way out is turning to the ancient synthetic philosophy which is given on this stage of the mankind’s development and defines the vector of development of the entire planet and which expresses God’s will. Russia is chosen the leading one in the context and it is the crucial fact. Religions and new doctrines are given to the mankind on the language the people of which are predetermined by God to fulfill the evolution destination (see the epigraph). It is no secret that the Russians and all the nations that consider the Russian language to be their mother tongue is the very nation.**

**These are some ideas taken from esoteric sources that support the point of view:** Nothing takes place accidentally. The receiver of the doctrine is not accidental and the language is chosen with purpose. The instructions were given in different languages and the conditions corresponded to the important circumstances which were of the world significance. The language on which the doctrine is given is the sort of a gift to the famous nation. The doctrine does not lose its significance because of it. Every truth is universal, but every nation has its task and obligation /18/.

During the last and the most important century, since 1917 to be exact, Russia has exploded the world consciousness twice, sacrificed itself and brought the consciousness to a new round. These are some lines from the letters of Mother of Agni Yoga:

“Russia took a burden of search of truth for everybody. It is in the search and fight and is doing it in immeasurable suffering among hardship, blood and sweat. The history inspiration is not on those who are well-fed

and self-satisfied. The fiery tongues inspire those who are anxious in spirit. The angel wings troubled the water of the front.”

“There are no any changes in the world... besides the fact that there is no Russia in the civilized world... and there is the change in this absence. Being in the sort of nonexistence Russia becomes the ideological centre of the world” /19/.

Prosperity of Russia is the guarantee of the world peace and welfare. Death of Russia is the death of the entire world... The results of the explosion in Russia are great. Russia which is purified and revived on the new origins of people’s wide collaboration and free cultural construction will be the stronghold of the real world /19/.

Reverend Lavrenti Chernigovski said: “Rus and Russian are our native words. We should not forget that there was christening of Russia, not Ukraine. Kiev is the second Jerusalem and mother of Russian cities. Kiev is impossible without great Russia and apart from it. The word “outskirts” is disgraceful and humiliating. The Poles legalized the words “Ukraine” and “the Ukrainians” for us to forget our title as the Russians and lose touch with Saint Orthodox Russia. As we can not separate Holy Trinity, the Trine, the Trias, the Triune, we can not separate Russia, Ukraine and Belarus. They are Saint Russia. You should know and remember it” /20/.

**Wise love to motherland** John Kennedy said: “I have hundreds of experts to build a pyramid, but I have none who knows whether it is worth doing...” The words prove that the modern western civilization has lost its development vector. The only way to restore it is the ancient knowledge of East. Here is the attitude of esoteric philosophy expressed by E.Roerich as to the problem of chauvinism which Ukraine suffers from: “The *reasons* for the refusal to publish the works of Richard Yakovlevich are the evidence of chauvinism disease. It is a psychic epidemic that covered many countries and the healthy elements are to struggle with it as it causes dangerous aftereffects. I am proud I belong to the country that has various nations and accepts and absorbs all features of the nations and learns from the neighbours and welcomes them. I considered the nations living in our country to be the members of the united family and when fate led me around the world and made me live in different countries I did not feel myself a stranger and loved the country that sheltered me from the bottom of my heart. Every person is to love his motherland but the love is to be

wise. **Imprudent love to motherland is as dangerous as the imprudent and partial love to children.** We should widen our mental horizon to understand where the country's welfare is and what it is in and **where the world evolution strives for** in order to catch its indisputable rhythm. Only then can we be called **the true patriots**. There are a lot of examples of the **death of the countries and their representatives who were chauvinists**. Chauvinism is close to hatred, but the hatred makes you blind. That is why the chauvinism is a poor advisor."

"Love to motherland is a wonderful feeling but the chauvinism is its antipod. It gives birth to the most awful features and it is the progenitor of any war. If we look through the history of culture, we will see that chauvinistic minds did not create anything which is great. The chauvinism is the spirit dungeon. We are to trust the Highest Justice but not the one which is comfortable and we are aware of. The one which was weighed on correct karma scales. We need to know the true history of nations and their countries, widen our opinion and understand, at least partially, the idea of what is going on. Armageddon is a sign of the end of the certain cycle. The world is transformed in fire and thunderstorm. Both Earth and the Universe are under the great stress. The stress grows not only in the battles but in the inner demoralization. That is why it is so important to introduce the signs of integrity and goodwill wherever it is possible. Let us not stir up hatred as each drop of it burns the best accumulations".

"Some outstanding physicists are working at the problem of extraction of intra-atomic energy and mastering it for the benefit of the mankind or for its unfortune. Taking into account the modern intellectual, moral and economic sate of our "thought rulers" and their followers and the fact that a pound of intra-atomic energy of the usual matter is more powerful than a million ton of dinamite as to its destructive force we will hope that the secret of intra-atomic energy release and mastering it will not be discovered today or this century" (Electricity Foundations) /21/.

The most mysterious researcher of the XX century N. Tesla said: "We are short of close contacts and better uderstanding among some people and communities in the world. We should eliminate fanatic devotion to magnified ideals of the national egoism and pride which are always ready to drive the world into barbarism and discords. Not a single union or law

are able to avert the catastrophe of the kind. It is only a new way to give the weak into the hands of the strong.../22/.

**Mathematical models of artificial intelligence as a sign to work out the behaviour of countries on the international scene** Mathematical modeling saved the mankind from death more than once (according to the calculations of the academician N. Moiseev there won't be any winner in the nuclear war). The result of the mathematical modeling in the field of artificial intelligence where machines can give the example of the best collaboration strategy is of importance. This coincides with the esoteric approach /23/: "In 1974 the philosopher and psychologist A. Rapaport from the University of Toronto said that the most efficient manner of communication among people was in collaboration, exchange and forgiveness. In other words, if an individual, a structure or a group meet other individuals, structures or groups the search of the unit is the most beneficial. According to the law of mutual exchange the partners are to pay back to each other. If your partner helps you, you should help him; if he attacks you, you should attack him the same way and your attack is to be as intensive as his. And finally you should forgive him and offer the collaboration again.

In 1979 the mathematician R. Axelrod organized a competition among the computer programs able to have the reactions which living beings have. There was the only condition: every program is to have the communication means and a chance to have a discussion with the neighbours.

R. Axelrod got 14 diskettes with the programs sent to him by his colleagues from different universities. Each program offered different models of behavior (the simple one – two versions of the action, the complicated ones- up to one hundred). The winner is to have the highest score.

Some programs tried to exploit their neighbour as soon as possible, steal points from him and change the partner. Others acted alone and were jealous as to their achievements and avoided the contacts with those able to steal from them. There were the programs with the following rules: "If someone is hostile to you, you should ask him to change the behaviour and then punish him." Or: "You should collaborate with him and then betray him all of a sudden."

Every program fought with each of the rivals two hundred times. The program of A. Rapoport equipped with the CMEF (collaboration, mutual exchange, forgiveness) was the winner.

More than that, the CMEF program when placed into the midst of other programs lost the aggressive neighbours at first and then won and “infected” the others as soon as it was given a little time. The rivals understood that its tactics was the most efficient and adapted to it. The test of time proved the method correctness. It is not a matter of kindness; it is the matter of your benefit proved by the computer programs.” That is the evolution essence of the machines is surprising. The mathematical modeling offers the development vector!

According to the prophecies of Lavrenti Chernigovski Kiev is the cradle of Orthodox Russia. Kiev is an apanage of Mother of God. Kiev lands were blessed by the apostle Andrew who put the cross there. Can the people of Ukraine allow the Satan servants to this ancient land and to power and in their hearts?

Everything which the Heavenly Queen foretold is sure to come true. The question is at the cost of what. Whether the Blood Rivers will overflow and thousands of tempted souls will die depends on many reasons and, first of all, on how wise politicians (and by their hearts too) and elected representatives of the Ukrainians will be /21/.

**Beauty as a criterion of the theory truth** According to the English physicist, the Nobel Prize winner Paul Dirac “we should start with a nice mathematical theory. If it is really nice it is sure to be a nice model of important physical phenomena. Thus we should look for the phenomena and develop the applications for the nice mathematical theory and interpret them as predictions of new physical laws. New physics, relativistic and quantum one are built this way.” Thus Dirac offers to pick the “nice” mathematical theories out of the huge amount of the mathematical models which can be created. Physicists are to use them to model different physical phenomena /24/. The same truth criterion can be used to search the national idea. From our point of view the esoteric approach synthesizes historical, moral and cultural wishes of all the nations of Ukraine and their brothers abroad. This point of view is really nice. Didn’t F.Dostoevski mean that when he said that beauty would save the world and N. Roerich specified that understanding of the beauty would save the world? That is why we

should follow the advice of wise people and turn to the Beauty, Equality and Brotherhood. N. Roerich wrote in his book “All- Slavic”: “Long live all -Slavic Unity!” and added in his book “Unity”: “The basis of lie and hostility is still strong. Everything which is opposite to the unity is still alive. We might survive the stage which is contradictory to the world unity. Nevertheless, there is a way here too. The nations are to recollect their roots and split into kins and clans. Exhausted centres will create a new and immense unity wave. New people will speak with all-human words. The dream about the unity is as far as that of the “golden age”. However it is viable too as it repeats the best dream of the mankind”.

**Conclusions: The national idea of Ukraine, even if it exists, is closely connected with the national idea of Russia which is the leading evolution idea of the world now. There is no other national idea of Ukraine. All attempts to do something in this direction artificially is the problem of the national egoism of the group of people who think that they have a right to speak on behalf of the entire Ukrainian nation. We do not claim to form the new national idea of Ukraine. We just speak on the way it is to go. We think that we have widened the search field and showed the direction. That is why the national idea of Russia and thus that of Ukraine and the entire world is in evolution understanding and self-improvement. The key to it is a new syntagma of the mankind expressed in the ancient wisdom on the current stage of development of Earth planet which is the doctrine of Agni Yoga and other esoteric sources. Nowhere else the priority thoughts on the coming Brotherhood are shown. The latest of the High Covenants was given in Russian. That is why the people who consider the Russian language to be their native tongue are to apply the Doctrine into life, that is, to fulfill the evolution mission. I repeat, we mean the coming Russia which is esoterically united with Belarus and Kiev Rus – Ukraine.**

We should say that there is a preconceived opinion as to what classical literature is to be published in Ukraine. Russian and Ukrainian classical literature is practically castrated. All that concerns Russia is crossed out mercilessly! What are the present-day apologies for politicians afraid of so much? The words of Taras Bulba are very topical now: “I would like to tell you, gentlemen, what our comradeship is. You heard from your fathers

and grandfathers how our land had been respected: we showed us to the Greeks and took tchervonets from Tzargrad; the cities were magnificent, churches were Russian and earls were Russian but not those catholic sectarians. The infidels took everything. We remained orphaned and the land remained orphaned as if it is a widow of her strong husband. We stretched our hand to the brotherhood at this difficult time. Our comradeship is based on it. There are no bonds that are more sacred than the comradeship! Father loves his child, mother loves her child; the child loves both its father and mother. But it is a different love! An animal loves its child too. But only a man can be native by soul, not blood. We had comrades in other countries, but we had no one like those living on the Russian land. You happened to stay on a strange land for a long time. You saw pilgrims and talked to them as if they were yours. But as soon as you wanted to have a heart-to-heart talk with them you understood that they were not yours! Nobody can love with all that God gave to you, but Russian soul. I know it for sure. I know that there is much meanness on our land: people want to have bread and horse herds and honey in their cellars only. They adopt infidel customs and disdain their language. They do not want to speak with friends and sell them as if they are soulless creatures in the market. They appreciate the favour of a strange king; the filthy favour of a Polish baron who hits his people by a yellow boot on their faces more than any brotherhood. But even the worst scoundrel though he is covered with ash because of worshiping has a bit of Russian feeling. He will wake up one day, come to his senses, and curse his foul life. He will be ready to expiate his disgraceful actions by tortures. They all should know what the comradeship on the Russian land means”.

Prelate Alexei asked Sergey: “What shall we do?” Sergey answered: “Help Russian land!” When peasants asked Sergey the same question, he answered: “Help Russian land!” When Minin addressed Sergey, he replied: “Help Russian land!” And added: “We should look at the unity of Holy Trinity and beat the hated discord of this world.” Let us consider these behests!



## References:

1. S.G. Dzhura. The Answer to the Question: “What do you think the President is to do?” // the Newspaper “Vecherni Donetsk”, №12 (8068), 22 January 2005.
2. Y. Khabermas. In Search of the National Identity. Philosophical and Scientific Papers. – Donetsk: Donbass, 1999.
3. Archbishop of Lvov and Galicia Augustin. About the Essence of Christian Patriotism <http://www.voskres.ru/idea/holy.htm>
4. A.P. Kovalev, V.V. Otkidach, S.G. Dzhura. On the Way to a New Syntagma// Wisdom of Earth Home. About the World Outlook of the XX Century. Edited by S.G. Dzhura, V.A. Yankina, and A. B. Kazanski. – StPb-Donetsk, 2007. – p. 160-169. <http://ethics.roerich.com/doc/kultura/sintagma.htm>
5. Betrayal as the National Idea of Ukraine. <http://www.novorossia.org/news/20081/171.htm>
6. S. Gorokh. The National Idea of Ukraine is Harmony. [http://dgerelo.org.ua/statti/nac\\_ideya\\_Ukrainy-garmoniya.htm](http://dgerelo.org.ua/statti/nac_ideya_Ukrainy-garmoniya.htm)
7. The Film “Undeclared War” [http://www.russtv.ru/content2/patriot/russ\\_otpor/otpor19.shtml](http://www.russtv.ru/content2/patriot/russ_otpor/otpor19.shtml)
8. M.I. Shterenberg. Global Crises and the Education Reform // Delphis №2 (50), 2007. [http://www.roerich.com/delfis/delphis\\_2007\\_2\(50\).djvu](http://www.roerich.com/delfis/delphis_2007_2(50).djvu)
9. A. Rotowski. The Ukrainian National Idea; from Cry to the Constructive Dialogue. Why does Ukraine Need the All-Nation Idea? // Mirror of the Week №34 (613) 9-15 September 2006. <http://www.zn.ua/1000/1030/54466/>
10. D. Y. Bondarenko. The Ukrainian National Idea as a National Utopia. <http://ideashistory.org.ru/pdfs/39Bondarenko.pdf>
11. D. Dontsov. History of Development of the Ukrainian National Idea. K., 1991. p. 40.
12. P. E. Kazanski (Quoted: M. B. Smolin. “Ukrainian Fog is to Go down and the Russian Sun will Rise”. Love to everything which is Ukrainian in Russia. The Ideology of Split. Ukrainian Separatism in Russia. The Ideology of National Split. Collection of Papers/ Introductory Article and Comments Made by M.B. Smolin. M., 1998.

13. I.A. Linnichenko. The Ukrainian Problem and Autonomy of Ukraine. The Open Letter to M. Grushevski. Pg.: Odessa, 1917.
14. N. Ulyanov. Origin of Ukrainian Separatism. M., 1996. p. 3-4.
15. A. Tsarinni. Ukrainian Movement. Short Historical Essay Mainly Based on Personal Memories// Ukrainian Separatism in Russia. Ideology of National Split. Collection of Papers/ Introductory Article and Comments Made by M.B. Smolin. M., 1998. p. 178-179.
16. Quotation from the Circular of P. Stolypin of 20 January 1910. Quoted from: Ukrainian Problem. P. 101.
17. M.A. Basin. I.I. Shilovich. The Way to Synergonet. – StPb: Norma, 2004.
18. O. Kryvdyk. The Ukrainian Truth  
<http://www.pravda.com.ua/ru/news/2007/2/26/54974.htm>
19. “The Overhead” (part 2), §468. <http://www.roerich.com/zip/brtwo.zip>
20. E.I. Roerich. Letters. 1929-1938. In 2 volumes. Vol. 1. – Mn.: Belarus Fund of the Roerichs PRAMEB, 1992.  
<http://www.roerich.com/zip/rerhltr1.zip>
21. The Prophecies of Reverend Lavrenti Chernigovski.  
<http://otechestvo.org.ua/main/20067/2110.htm>
22. Letters of E.I. Roerich. Volume VII (1940-1947). – M.: MCR, 2007. p. 251. [http://www.roerich.com/zip3/ei\\_7.zip](http://www.roerich.com/zip3/ei_7.zip)
23. B. Weber. Encyclopedia of Relative and Absolute Knowledge. M.: Repol Classic, 2007.
24. N. Tesla. Papers. - Samara: Publishing House “Agni”, 2007.  
[http://www.roerich.com/zip3/tesla\\_st.zip](http://www.roerich.com/zip3/tesla_st.zip)
25. A.P. Stakhov. “Harmony Mathematics” as a new interdisciplinary trend in modern science  
<http://www.trinitas.ru/rus/doc/0232/004a/02321078.htm>
26. N. V. Gogol. Taras Bulba. <http://ilibrary.ru/text/1070/p.11/index.html>

## 7.2. Commanded synthesis

A.V. Levshov, S.G. Dzhura, V.I. Chursinov

*The modern science problems are analyzed. The ways out of the world outlook crisis which is the basis for the economic one are offered. The application of the synthesis from a historical point of view is grounded and the outlooks of its application to solve principle tasks are shown.*

**Introduction** We totally agree with the position of the editorial board of the Delphis journal on the synthesis being one of the most significant principles of the evolution in respect to its course and informative steps in its understanding. As far as everpresent general rules of organization of systems are concerned the principle of Hierarchic structure is the prior one. It does not mean the priority of opposing forces but domination of the forces which supplement each other that is their synthesis. The principle of Reasonability, “Golden” Harmony and Beauty which runs through the nature including man is traced in it. It gives birth to participation and involvement the peak of which in its highest human demonstration is Love.

The synthesis unites which is the demonstration of the great Unity that rules in the Universe. It resists chaos and an eclectic structure of the world outlook constructs. It is the synthesis only that defines the cognitive process vector that expresses the direction of the development of the world itself and a man in it, his physics, mind and heart and makes up the basis for the involvement in all natural interrelations. /1/

**Synthesis inevitability** is illustrated by the paradox described by Henri Poincaré in his synthetic paper “About Science” /2/: “The number of lines which can be drawn through the point parallel to the straight line

- Equals to a unit in Euclidean geometry;
- Equals to zero in Riemann geometry;
- Equals to infinity in Lobachevski geometry.”

That is why people often do not have anything in common with each other (which might cause wars and other conflicts). They do not know the concept of the synthesis. It is like the parable that says about seven blinds that touched an elephant and made different conclusions as they came up to

the animal from different sides. They were ready to fight and shout themselves hoarse to persist on their opinion and reject that of the others which, as it appeared, was also true.

Gnostic sources (including Agni Yoga) read that the Universe Truth can not be covered by a single religion, science and philosophy. It only shines by a side of the Truth. It is sure to be difficult to understand the world real picture without the synthesis of knowledge. E. Roerich wrote: “The Great Traveller taught to widen the consciousness. He repeated: “Open your eyes and ears”. Of course, he meant not only his doctrines. He just showed how deep the essence is if the consciousness is widened. But you can not threat the needle with a rope. There is no room for a big message in a small ear. We can imagine how many of his doctrines did not come into listeners’ ears! Many of them were memorized as fragmentary. The link was lost and so was the original idea.” /3/

We know only some sciences which, like a mosaic, lighten some parts of the picture of the Universe where there are so many blank spots. It is only the synthesis understanding that allows some encyclopedia personalities to see the future and share the truth picture with the rest. E. Roerich is sure to be one of these prophets who wrote: “The problem is that we do not assess the given things and occurred events immediately and in commensurability and a detail and a fact which might not be bright but are of the greatest importance are overlooked or, to be exact, are not covered by our consciousness. We are to get used to the fact that all that happens around us and given by Hierarchy is of profound significance. It might not be evident now but tomorrow it will be trumpeted in the squares. Who knows the evolution direction? Who can say what the current chaos will be resulted in? Who knows which forces will raise? That is why go and be careful and trust the Ruling Hand!” /4/

The current science is on the threshold of the commanded synthesis of science, religion and philosophy.

**The coming synthesis** has been looked for by religion, science and culture for a long time. Patriarch Kirill says: “Holy fathers combined secular scholarship with theosophy and formed a synthesis. The famous theologian Georgy Florowski called it a patristic synthesis. He dreamt about the appearance of the new patristic synthesis for the modern generation of theologians to learn to combine the external secular culture

with theological creativity for the latter to be able to fecundate the culture and the words of Church to be topical. I pray and hope for the dream of father Georgy Florowski to become a reality nowadays.” /5/

The greatest scientist of the XX century, historian and thinker V.I. Vernadski expressed the point of view of science on the problem: “Neither scientific world outlook nor its religious and philosophical systems are a synonym to the truth. They are just approaches to it, different demonstrations of the human spirit.” According to his words “Christianity did not learn sciences in the field, but gave more profound definition of its essence. The science can not break Christianity or any other religion in an alien sphere, but it can define and understand the forms of its vision.”/20/

A.D. Sakharov said in his Liyon lecture that science is characterized by three interrelated features: aspiration for learning and creativity; practical significance; forming of the unity that cements the mankind. The virtual reality technology provides intellectual polysensor communications with subjects (objects and phenomena) of the virtual world from different points of view and gives a user a chance to form and analyze the versions of a distant international cultural exchange and thus fulfills the most important function of science development /6/.

A. Schnittke agrees: “The ordinary mind looks for the problem solving on its own plane, it creeps bravely on the surface until it finds the way out by the error and trail method. The mind of a genius looks for the solution at the universal level where he sees everything from top and finds the correct way at once. That is why those who save their time for one problem always achieve less than those who deal with related problems.” /6/

It is the very synthesis N. Roerich spoke about: “An ignorant person is to become civilized first, then educated, than intellectual, then sophistication and **synthesis understanding** follow and this finishes with acceptance of the concept of Culture.” /7/

The synthesis is shown on the Peace Banner – three circles in one. N. Roerich interpreted the symbol as a religion, science and art in the circle of culture. Madonna Oriflamma keeps the banner with the symbol in her hands on the famous painting of S. Roerich.

We think D. Mendeleev also spoke about it: “The time will come and the entire world will be involved in one science, one truth, one industry,

one brotherhood and one friendship with the nature”. /8/ That is one proved theory that can be accepted by everybody – believers, atheists, researchers and all people- is to be adopted.

**The problem: “Do people deserve the cognition of the Truth?”** It is the cornerstone problem of the evolution. How is the knowledge to be given for the people not to put it for the evil ends? The life new Covenant started with the words “I am giving you a new behest”. The words start the proclamation of every new doctrine that declares the truth, which is as old as the hills, in a new and an unusual form. The truth is single and inexhaustible but human brains are limited by their capacity. That is why the truth is given in evolution and in size allowed and defined by the degree of the evolution of the Earth mankind. We do not give more not because we do not have more, but because there is no room. Even if there is a room, it might be put for the evil ends. If people were burnt on fires and tortured by red-hot iron in My Name, what would they do in their names if the banned formulae were disclosed? That is why they are not to claim that mysteries are revealed only to spirits that came to us forever, do not know the way back and were tested for many millenniums. The fire is trusted only to the nearest.” /9/ Prof. A.V. Kenyukhov (DonNTU) writes in the chapter “Economics and Religion: Paradoxical Dialectics or Why did Christianity Create Satanic Economic Model?” of his book: “As I have already shown in my previous papers “People-Shadows” and “The Consuming Society as the National Tragedy of Ukraine” hypocrisy is the main cultural tradition of the society with the double moral. It is it that defines the form of the “correct” behavior of any member of the society.

There is a direct and close interrelation among the actual moral principles, cultural traditions and economics.

Economics, I emphasize, is the way to satisfy the material demands of the society. As our Ukrainian society is the Christian one, according to the majority of believers, it is to form the Christian economic model to satisfy its material demands. That is it is to build the economics that functions on the Christian principles of kindness and love to neighbours, honesty and justice. So there is to be fair distribution of added value between an employer and an employee, fair competition and caring attitude of a manufacture to a consumer and vice versa, absence of businesses based

on the cult of a sin and a vice (prostitution, drug pushing, producing of sausages made of rotten bones with rat tails).

However we have the principally opposite economics that functions on the principles of envy, avidity, injustice, meanness instead. That is the current model is based on the evil anti-Christian and satanic principles. The main actual anti-Christian principle of business is: if you do not eat, you are eaten!

There is a paradoxical question: why did the Christian society create the satanic economic model?" /10/

Prof. A. Kendyukhov states that there are many people who believe in Christ but there are no the Christians in our country (Ukraine): "Let us recollect main principles of his life. Christ called not to glorify him but follow him and repeat his way by our lives. Christ was a practitioner but not a theorist. The Christians who followed him were practitioner too. Judah was a Christ believer too but he was a Christian-theorist. His practice was the life of a member of the corrupted society. The betrayal of his teacher for 30 silver coins, thirst for profit and the mercantile nature was the practice of Judah who believed in Christ.

Christ demonstrated the spirit strength and despised the power of gold and material wealth. He, like those who followed him, Peter or Matthew and other apostles, did not wear expensive clothes decorated with gold as those who consider themselves to be their followers do. But the inner greatness of the real followers of Christ was covered by the clothes simplicity. What is covered by the expensive clothes of today's believers? Do they despise the material wealth as Christ did? Maybe they "despise" it as Judah did? Are there many people in the current Christian society whose life is the challenge to evil, injustice, betrayal and moral degradation? Are there many of them who are not afraid of seeing the evil? Who can not put up with it like Christ could not? It is possible to believe in Christ and live the life of Judah.

What changed for the latest two thousand years? The main motive forces are the same satanic ones as it used to be in the pre-Christian period: envy, avidity, hypocrisy, arrogance, lie, meanness, and betrayal. The crowds of the Christians worship to the golden calf.

Christ would be crucified again if there were Second Coming and Christ would advocate to the Christians what he did to pagans two

thousand years ago, demonstrate his disdain to the avid and the wealth saved up by them, condemn those who climbed the power tops over heads of each other as if they were monkeys, or condemn priests who glittered with their gold chains and rings and rode the Mercedes and consecrated trade centres as if they were temples. They would shed a few tears and say that it was for salvation” /10/.

To sum up: “Today we observe the historical moment of falling of the Western civilization and that of rise of the Eastern one. This would not have happened if there had been a real belief, not hypocrisy, in the consciousness of the majority of Western Europeans.

Thus, the economic model created by our society is not a paradox but a mirroring of the actual social moral which is the moral of the total hypocrisy.” /10/

We think the author of the mentioned lines dramatized but nevertheless we agree with his term of economics being the world outlook variable. As far as religion is concerned the synthetic point of view says that it has its own truth but people see only a part of it and carry the heaven ideas into our world that inevitably distorts the original (the primary source). More than that, there is a mathematical theorem of A. Tarski\* on the truth ineffability: “The concept of the arithmetical truth can not be expressed by means of arithmetic.” /2/ The synthetic man (in the interpretation of N. Roerich and God-man in the interpretation of M. Dostoyevski) of the future only will be able to enter the future with this synthetic world outlook. Otherwise the current mankind will be able to kill each other as the six blind from the Bible parable shown in the painting of Pieter Bruegel “The Blind” did. Scientists often operate with the concept of the “synthetic man”. Culture as the synthetic symbol of science, religion and art (S. Roerich) gives the practice of the roads that were not passed and the clever learns from the mistakes of others though they are not as intelligible as the own ones. The mankind is to choose the evolution vector. The Gnostic sources give the clear answer: “The world politics and economics have never been and will never be the evolution decisive moments. The evolution goal is to create the man who is able to think with Space categories but not the man who is able to think correctly. The politics, economics and the social structures created by them teach the man to understand the matter on minor and temporary examples only. It would



be ridiculous to think that justice and injustice of these short-term forms of the human's social life are Space Mind typical yardsticks" /12/.

What is the point of the evolution lessons? The answer is in the Gnostic wisdom: "The power of darkness is stronger before the Light coming. When it comes to its apogee the foretold will come. You should judge upon this sign. The victims will be huge as the future is great. Everybody will bring its own to build the Future Temple. To create something new the old is to leave life. The struggle of the new with the old will finish by the total victory of the former. The old will be sacrificed. Many will suffer and are suffering. But the evolution acts regardless the victims and the sufferings. The entire species of animals and plants will be destroyed for the sake of the final goal. Races and civilizations will die to give the place to new ones. The luxury of Babylon, the knowledge of Egypt, the culture of Greece and the power of Rome were replaced by life new state forms and the past was buried under their wrecks forever. The nature is generous- it destroys one form and creates others immediately. The life of a separate person and his interest mean nothing in the flow. According to the life law everything which is alive clings to life but it dies in the endless form change. The form is lost but the essence is preserved and gets its new and improved form. The form is nothing and the essence can not be destroyed. The experience gained by the form enriches, deepens and transforms the essence which does not die as the endless and countless power seed. The life essence potential which is in the physical form, which means nothing, is also inexhaustible. The eternal and immortal is shown in the mortal to demonstrate its essence in the evolution endless process" /12/.

**Scientific and religious idea synthesis** The activity of the Delphis journal and those who united round it is based on the synthetic approach. Science, religion, and art supplement each other and do not reject. The position is stable when at least two branches of the knowledge are operated by.

Everybody knows that any computer has the BIOS( Basic Input-Output System) without which it can not operate as it is the first one to be loaded and only then any operating system and all applied programmes are loaded. If there is no BIOS (or if it is broken), it is impossible to load any operating system. We can find the analogy in this sense in Holy Scripture: "The one who has will have some extra; the one who does not have will

lose something.” **The second:** There is the concept of emergency in the system theory – the presence of the system special characteristics which are not inherent to its subsystems and blocks and are not equal to the sum of elements which are not connected with each other by special links which form systems; irreducibility of the system characteristics to the sum of its component characteristics; the synonym is “the system effect”. Here we would like to mention the metaphysics of Aristotle: “The whole is bigger than the sum of its parts”. The Holy Scripture reads: “Where two or three are gathered in my name, I am among them.”

Pitirim Sorokin created the theory of social and cultural dynamics developed on the basis of the synthesis of religious and scientific ideas which differs his approach from the view of the majority of scientists who build their culturological and sociological concepts on the circular basis.  
/13/

The advantage of Sorokin’s theory is in the complex of fundamental values formed in the Sermon on the Plain and ethic systems of other world religions which is the axiological basis of functioning and alternation of the social and cultural types. The values are universal and control the past and present civilization dynamics. The degradation of the values leads to the moral anarchy and culture level reduction which, according to Sorokin, is typical to the modern Western civilization being the society in which sensual mentality dominates. He wrote: “The human fate balances on the brink of life and death. The blind leaders and their ignorant followers lead the mankind from one catastrophe to another instead of creation of the happy environment. They will do it until it appears on the edge of senseless death.” /13/

The optimistic mood dominated in his works. Sorokin was able to see the light at the end of the tunnel. There is a historical law according to which “the catastrophe periods are marked by disintegration of the value system of the society and growth of demoralization, crime, wars and bloody fighting on one hand and by creative reintegration of the new value system on the other one. If the forces of positive polarization prevail over those of the negative one in this crucial confrontation, the mankind will be all right.”

Sorokin feels the necessity of the truth but it escapes from him and he exclaims with some annoyance: “Mysterium tremendum et fascinosum” (the mystery is horrifying and exciting”).

How can we understand this elusive but such an important mystery? While solving the task Sorokin turns to the modern **integral theory of knowledge** according to which there are three channels of information getting: sensual, rational and super sensual (super rational or intuitive). The super conscious intuition is the tool with the help of which the man makes greatest discoveries in all the spheres of his creativity. The super consciousness that controls the intuition is the origin of the discoveries. /13/.

The logic cognition and the integral experience are based on super conscious intuition. Sorokin emphasizes that the intuition is not selfish: “The individual who is controlled by the super consciousness becomes its impersonal tool that is over the limits of Ego” /13/.

The analogous statement is in Gnosis: “The collective influence of the mass is great. If the people acted in harmony and spirit balance the result of this powerful influence on the nature would be opposite. As far as the situation is different now, there is no ray. The mankind answers with the greater misbalance to every natural one. There is the vicious circle and the way out is on top. But we refused to look up to the sky as we had closed it or replaced by gold. The people dash around in confusion. They will dash until I come. I will rescue them.” “If you are told: “We turn but it is fruitless” you should answer: “It means that you do not observe the psychotechnics principle.” There are rules and laws in engineering and psychotechnics. You can not avoid them but the results appear soon if you observe them. There must be two poles. We enter cognition of the consciousness laws, which subtle energies obey, into the psychic area. Psychotechnics is the future science. It, like any other science, will be studied, and the obtained knowledge will be applied into life.” /9/

Sorokin anticipated the fundamental importance of the super rational intuition and its origin – “the true space reality” but because of the science state of his time, he was unable to make the next step and answer the question: which physical referent is behind this original “docta ignorantia” (the term belongs to N. Kuzanski) /13/.

Sorokin referred the future of the world civilization being the integral self-organized system to the culture integral type which will unite all the best features of the previous types. Pititim Sorokin admitted that the modern society in the West and in the East was in the state of the profound crisis and gave his optimistic forecast: the mankind will not die as there will be the end of the sensual and the beginning of the new integral evolution cycle of the world civilization /13/.

The Gnostic wisdom proves it: “The wise men are limited in their state wisdom as they are blind. Only those who obey the outline of Hierarchy will win and be successful” /9/.

**Space pedagogic.** Gnosis shows us how to get the direct knowledge from the “noosphere, space data base or God, as you wish”, said V.V. Puck. Gnosis interprets the statement as follows /9/: “The scientific understanding of the verities is approaching. When a thought is concentrated on the Teacher the process becomes stronger and has the seal of the Teacher’s thoughts. Thus the thoughts come from the Highest World to Earth and belong to people. The best one record them, know their origin and call them the Voice of Divine Forces, the Light Forces, the Highest Forces, the Voice of God. When the divine force, that is the highest force of the Lord, is imprinted by the consciousness, the receiver has a right to call it the Highest thought. The ancient people chose the words that were understood by the people of that time. Today we can call things by their right names and explain the process technique from the scientific point of view.” The authors offered the process scheme in 1994 /21/. St. John the Divine, K.Tsiolkowski, and Jakob Böhme got their Revelations and Nikola Tesla made his unbelievable discoveries this way. This cognition method can not be modeled by the computer and algorithmized (this is the method of discovery, invention and illumination which is called the mechanism of the right hemisphere). It is Gnosis that gives us understanding of the famous phenomenon that the brain, even if 30% of its volume is destroyed, goes on thinking correctly ( it is the data of field medicine) which is impossible for a technical device which stops operating because of breakage of one element (TV, for example). Gnosis explains it: “The thought seat is to be looked for higher. Coats are just devices or tools for thinking. For example, brain is the physical body device. The brain can be destroyed but the memory can function actively. The physical body death

does not stop thinking process. It makes it even easier, more intensive and mobile. Thinking stops neither during the day nor at night. The brain dies but the thought goes on working. The thought goes in its course. The thought of each person goes along the channels typical to the man” /9/.

A professor of the University of Stuttgart, the world leader in the field of artificial intelligence, was asked a question “what is man?” at the international conference held at DonNTU. The answer was “I do not know.” The Honoured Doctor of our university shrugged his shoulders and left the floor. He demonstrated the deadlock of the scientific world outlook. The Gnostic wisdom says: “The man is something bigger. The man is a multidimensional body extended in space on a long distance and going to the million years’ past and the endless future. The body is of different planes stretched in the space of some dimensions. It is invisible in what we call a man in the main” /9/.

The authors presented their vision of the man scheme (in which there is the 11-D picture of the reality with the ancient conceptual device) at the international conference “Ethics and the Future Science” in Moscow and StPb in 2011 and at the international congress on computers in Portugal in 2012 /22/.

**Conclusions:** The Nobel Prize winner Prof. L. Landau said that “there were natural, unnatural and super natural sciences.” He is likely to speak about humanitarian and natural sciences and those that study Gnosis (which have not been included into the world outlook and scientific tools of modern science –Agni Yoga, Theosophy and THE because of rejection of the synthesis). The modern science is unable to explain a number of problems and phenomena and behaves as an ostrich that hides its head into sand. We think that the science is to develop in the synthesis with religion and art (they are integrated into each other very well). As all sciences originated from philosophy we should study Gnostic texts as they help the mankind find the way out of the crises which are, first of all, the world outlook ones (we would like to remind you that economics is a derivative of the world outlook). We agree with the Nobel Prize winner H. Heisenberg when he says that the first swallow from a cup causes atheism, but God waits for us at the bottom of the vessel.” /14/ The leading universities of the world (Harvard /15/, Oxford /16/ and Cambridge /17/) have faculties of theology. That is the aspects of the synthesis of science

and religion are studied there. But it is not done at the motherland of the first European computer and the mobile communication. The situation is being changed now. There is a section “Science and Religion are Full Sisters” on the portal “Education: Researched in the World” /18/. The book “They Believed in God: 50 Nobel Prize Winners and Other Great Scientists” /14/ and the book of K. Tsiolkowski “The Scientific Belief Shield” /19/ which is called “Tsiolkowski’s Gospel” prove it. The Gnostic text reads: “We can not use the limits of the blind and narrow materialism as a cover any more. The science stepped over its boundaries long ago. The sphere of powerful unexplored energies is in front of it. It is waiting for brave minds that do not reject the reality. It is the epoch of great possibilities that are given to man according to the Space Right. We are not to miss, reject or pass by the calls of the new epoch. We are to be brave to admit the great reality which can not be denied” /9/.

#### References:

1. XI International interdisciplinary scientific conference “Ethics and the Future Science” with the subject- matter of “Idea Synthesis”. <http://www.delphis.ru/journal/news/xi-mezhdunarodnaya-mezhdistsiplinarnaya-nauchnaya-konferentsiya-etika-i-nauka-budushchego>
2. A. Poincaré. About Science. Edited by L. Pontryagin. - 2nd Edition. – M.” Nauka, 1990.
3. E.I. Roerich. Letters. Volume VI (1938-1939). — M.: MCR, 2006.
4. E.I. Roerich. Letters. Volume I (1919-1933). — M.: MCR, 2011.
5. Speech of Patriarch of Moscow and All Russia Kirill in t he Kiev-Pecherskaya Laura <http://patriarh.in.ua/uk/node/421>
6. D.I. Shapiro. The Virtual Reality and Neurocomputing Problems. M.: RFK-Image Lab, 2008.
7. A.P. Kovalev, V.V. Otkidach S.G. Dzhura. On the Way to a New Syntagma// Wisdom of Earth Home. About the World Outlook of the XXI Century. Edited by S. G. Dzhura, V.A. Yankina, and A. B. Kazanski. – StPb- Donetsk, 2007. – p. 160-169.

8. Y.A. Urmantsev. Nine plus One Sketch about the System Philosophy (The World Outlook Synthesis). – M.: 2001.  
[http://raen-noos.narod.ru/lib\\_urmancev1.htm](http://raen-noos.narod.ru/lib_urmancev1.htm)
9. Sides of Agni Yoga. 1954. – Novosibirsk: Algim Company. 2008.  
[http://www.roerich.com/zip3/grani\\_54.zip](http://www.roerich.com/zip3/grani_54.zip)
10. A.V. Kenyukhov. The Country of Hopes which do not Come True.  
[http://kendyuhov.in.ua/index.php?type=full&name=press/press\\_7.htm](http://kendyuhov.in.ua/index.php?type=full&name=press/press_7.htm)
11. P.F. Belikov. The Family of Roerich. The Practice of a Spiritual Biography. <http://www.roerich.com/zip/belikov.zip>
12. Sides of Agni Yoga. 1956. – Novosibirsk: Algim Company. 2008. [http://www.roerich.com/zip3/grani\\_56.zip](http://www.roerich.com/zip3/grani_56.zip)
13. L.V. Leskov. Non-linear Universe: a new Home for the Mankind. – M.: Economics, 2003.
14. T. Dimitrov. They Believed in God: 50 Nobel Prize Winners and Other Scientists. <http://www.scribd.com/doc/57443177/4/>
15. Theological School of the University of Harvard.  
<http://www.hds.harvard.edu/>
16. The Faculty of Theology of Oxford University.  
<http://www.theology.ox.ac.uk/>
17. Theological Federation of Cambridge University.  
<http://www.theofed.cam.ac.uk/>
18. Education: Researched in the World. <http://www.oim.ru/>
19. K.E. Tsiolkowski. The Scientific Belief Shield. – M.: Samoobrazovanie, 2007.
20. V.I. Vernadski. About the Scientific World Outlook // On its Turning Point. Philosophical Discussions of the 20s. Philosophy and the World Outlook. – M., 1990.
21. S.G. Dzhura. Practice of Teaching of the World Outlook Aspects of Agni Yoga in the Course of “Computers and Programming”// Humanization of Education at a Technical University: theses of the speech at the regional conference. - Donetsk: DonSTU, 1994.
22. S.G. Dzhura. Multidimensional Consciousness// Oriflamma. – 2011, №29.

### 7.3. Cultural integration of the future Europe

A.V. Levshov, S.G. Dzhura, V.I. Chursinov

*The practice of implementation of the TEMPUS program grant in five European countries is analyzed. The hypothesis of the concepts of metaknowledge, knowledge hierarchy, the approach to metaenergy and the mankind's knowledge is offered. The practice of implementation of the concepts at Donetsk National Technical University is shown.*

**Introduction** The delegation of England at the Day of TEMPUS in Ukraine that has been held recently said that there were fewer problems between Ukraine and Europe than among the countries that were European. We think that researchers from different countries are representatives of different cultures. The result of the dialogue between them depends on the cultural integration. Here is a typical example taken from the Internet. One of the travelers met a tribe chief from South Africa and got a spit in his face which appeared to be a sign of great respect! The nations living in Europe have some special signs of hospitality. They are to be known otherwise there will never be a dialogue or joint work between them. The EU is interested in integration with Ukraine and the obtained grants prove it.

The problem might have been the key-note for the future grant. Today each delegation is to improvise which is not the best version as the best impromptu is known to be the prepared one.

Culture is paid little attention to in Ukraine. There are some papers called "Put a Word in for Poor Culture" and sometimes the problem is suppressed. Prof. E. Mortyakova informed us that the social economics had proved that it was impossible to raise the life standard of a country without raising that of culture.

The experience of the universities of Portsmouth (Great Britain), Cadiz (Spain), Lodz (Poland) and Vladimir (Russia) was useful as far as cultural integration is concerned. We think it to be an additional result which is to be developed. Here we would like to tell you a story of our staying in Lodz. Our coordinators took us to the concert hall. After the concert the head of our delegation said: "We have just come back from the concert hall named after Sergey Rubinstein who lived and worked in Lodz.



We listened to the concert of Sergey Rakhmaninov who was born not far from the city of Vladimir (Russia) and the Russian delegation is at our table now. We have also visited Portsmouth (Great Britain) recently and were shown the concert hall where the legendary English band the Pink Floyd gave the first concert. When we were in Spain we sang Spanish and Ukrainian songs as well as those of the Pink Floyd on the seacoast in the evening. “Besame Mucho” was a hit. We also sang the songs of Che Guevara which power engineers and electricians working at the power stations we visited remember very well. When we gather for the final meeting in Donetsk we will sing Russian and Polish songs and take our partners to the concert hall named after Sergey Prokofiev who was born and composed in our region. My toast is to the future of Europe. We are the crew of the ship called “The Future Europe.” The ship course depends on every crew space (Polish, Russian, Ukrainian, English, and Spanish) work. New community of people –scientists who show how the future Europe and even the entire world are to interact- is an additional result of the grant. We should work not watching boundaries, political, racial, religious, and financial and other mismatches. All this is united by the concept of culture that involves religion, science, economics etc. Our toast is to our team who not only works well and represents the future Europe but also is an orchestra in which every delegation plays its own part. We think that the symphony played at the project is nice and it will always sound in our hearts. I would like to toast to our team and the fate that gave us the chance!” The speech won applause. We think there is a positive result of the work despite its assessment by the EU. The interim report was recognized to be a success and we are sure in the future.

To sum up we would like to discuss what we learnt from each of the delegations. Let us start with Russia. The Russian language is our native tongue and we did not have any problem with this. We visited Vladimir and Suzdal that are the pearls of Russia’s Golden Ring. We saw paintings of Andrey Rublyov and kissed the relics in the cathedrals of Vladimir and Suzdal. We think we had both spiritual and cultural contacts. Our delegation was interviewed on TV and sang songs for every delegation in their language. It was a part of our symphony.

Portsmouth. We appreciate English traditions too. We were at the stadium of the Chelsea club and took a photo with the picture of the

Ukrainian footballer A. Shevchenko who played for the club. Then we visited the famous Stonehenge where our Prof. Anoprienko delivered his lecture on archeological modeling to English archeologists and presented his version of the construction of Stonehenge. Then he showed Woodenhenge to our English colleagues and they were surprised as none of the delegations had asked them to do it. Then we were asked to an English club and the English coordinator said: “This is the man who taught me, the Englishman, during the excursion about England!” Thus we had a cultural contact there too.

Spain. We remember the visit to the Department of Culture that inspired us to establish the Institute of Culture at our university. It is an additional result too. The Institute of Culture operated at DonNTU 50 years ago and now it works in the following areas (prompted to us by the visit): the world film masterpieces; the world painting masterpieces; new trends in science; music; theatre.

There was one more important event. The Ukrainian project coordinator was awarded the diploma of the International Roerich Prize at the Hermitage.

**Metaknowledge through the Internet** To understand the problem we should back away. The more the distance is, the better we can see the matter. V.V. Puck wrote about it in his works. He stated it at the meeting with electrical engineering students of DonNTU in 1997. The administration of the Faculty has always given the chance to the students to develop new ideas. They introduced the seminar in which remarkable researchers made their presentations and thus created the environment for the ideas that was resulted in a number of projects: Moscow interdisciplinary conference and the Institute of Culture of DonNTU that renewed its work after 50 years of being neglected. The structure was presented as an additional result of activities related with the TEMPUS project (JEP-27085-2006) grant. The research showed that it was impossible to improve economics without rising of the role of culture. Thus the first postulate states that the farther we will back away the more accurate the forecast will be. G. Tesler stated the second postulate in “New Cybernetics” /1/: “There are two important results in the works of Gödel. It is the impossibility to prove consistency for any wide system that includes all arithmetic in the frameworks of the system and the existence of the

principle limitation of the possibilities of the axiomatic approach. Not a single solving of the arithmetic system can make it complete. These contradictions can be solved only on the basis of meta-theories and meta-approach. The results have arithmetic proof, common methodological character, and can be applied to the systems of any nature” /2/.

**Knowledge hierarchy** What is the knowledge? According to the definition “Knowledge is an ordered scope of new characteristics of a subject and the world and their interrelations represented in the form of a particular meta-text. The knowledge transfers separate images into the systematized meaningful form and keeps everything that can be saved, transferred and developed. **The problem of knowledge, the structure, appearance and the specific nature of its cognition and understanding is a philosophical, methodological, scientific, humanistic and applied one and can be considered one of the most complicated problems**” /2/. **We would like to propose the knowledge hierarchy hypothesis: information-knowledge- meta-knowledge.** The ordinary non-structuralized information is the fundamental principle out of which the knowledge is formed (let us call it the applied one that is necessary for the everyday life and earning for the daily bread). The knowledge from the capital P is the one that gives us the chance to find the way to the Eternity. It is getting of the meta-knowledge that is historically given to the mankind through prophets and Teachers. The knowledge was obtained through insights that are being studied thoroughly. Jakob Böhme, a shoemaker, William Blake, a semiliterate engraver, uneducated prophets Ezekiel and John the Apostle (with his terrible the Apocalypse), K. Tsiolkowski that had no education at all, Edgar Cayce and John Keely had such insights /3/. It is the way of cognition all great people went through including the famous power-engineering specialist Nikola Tesla. V.I. Vernadski said: “The space forms the Earth image...”

**Metaenergetics** We wrote about N. Tesla’s phenomenon in the previous proceedings of the Electrical Engineering Faculty /4, 5/. We also wrote about John Keely /6/ that was a mathematical genius and had the unique principle that made it possible to control the energy of the spatial ether. He succeeded in bringing it down to the Earth being not initiated to the final Mysteries. Although Keely’s devices operated due to the ether power, his own psychic energy was the trigger that activated it. **The result**

**might be considered the prototype of the remote ability of the mankind to get the energy not from the Earth interior but from the Space depth.**

N. Tesla and J. Keely can be called the Future Messengers. An ordinary person might want to know why it is impossible to be repeated nowadays. The answer is the following: “The representatives of the modern fifth race deepened themselves to the substance very much and were not allowed using the spiritual spatial energy (with a commercial purpose!) as it might threaten their lives and the life of the planet as its power had no boundaries both in creating and destroying” /7/. N. Tesla drove the ether by another method, and got the energy for his engines from it. The issue is very complicated and whether the mankind will transfer from ordinary exoenergetics to metaenergetics depends on its solving. When we say metaenergetics we mean non-fuel ecologically friendly energetics of the future. Its existence is possible as technology ideas had been taken from science fiction and many of them were implemented (flight to the Moon, robots, submarines, the Internet etc.).

**The contribution of DonNTU in metaknowledge getting** We spoke about it at the beginning of the paper; however it was especially evident in 2008 when one of the representatives of the EEF was working at creation of the Internet resource devoted to understanding of the metaknowledge. First the material was accumulated, and then it was discussed at forums and more than 20 related projects. The history and explanation of it is given in the paper /9/. In 1991 the project Oriflamma <http://roerich.com/> on creation of the e-library on the synthesis of science, religion and philosophy appeared. In 1997 it was recognized in the I-net and got Ukrainian and international (2008) rewards /10/ that proves the recognition of understanding of the metaknowledge concept. In 2008 international experts called the project the best in the world as to the synthesis of science, religion and philosophy. The project got the diploma in the nomination of “Roerich’s Heritage Preserving”. The Director of the Hermitage Mr. Piotrovski /10/ who is the chairperson of the club of St. Petersburg’s residents handed in the diploma to the representative of the EEF at the State Hermitage. All the staff of DonNTU deserved the reward which is the motivation for continuation of the work. The paper is the contribution into understanding of the e-library ideas.

**The mankind's knowledge.** The Oriflamma project is implementation of the idea of St. Petersburg researchers. /11/: “Knowledge, from the point of view of a separate person, is the information on possible results of the future processes in which the person is going to take part, on possible implementation of favourable or unfavourable results, on the methods and ways of influence on the possibility... Thus there are a great number of elements of knowledge of separate people that can be of help for all the people or many of them. The knowledge can be called the mankind's one. As all the people are interested in it they have to be organized in order to solve three tasks.

1. To provide maximal (free) access to the knowledge for all the people. Such means as books (libraries), newspapers, the radio, TV, leaflets, the Internet, the Synergonet increase the survival of some people and all the mankind as it is a complicated self-organizing system.

Any structure formed by people and making financial, and information obstacles for spreading the knowledge worsens the future of the mankind and a separate quantum and is criminal. The statement can be the criterion of the criminality and the totalitarian nature of regimes irrespective of their opinion on their own democratic character. One of the main or even the main criteria of the power criminality is not only the number of people killed by the power but the amount of the mankind's knowledge that was not brought to all the society members' notice free.

2. To provide decent living to the people who participate in getting and spreading of the knowledge necessary to all the mankind. It concerns the material and information living of researchers, pedagogues, journalists, culture representatives and religious figures”. We think that the matter is in the metaknowledge. It was implemented in the project Oriflamma fulfilled and supported by DonNTU.

**Conclusion:** We think the cultural aspect of the grant to be of importance. There is the so-called fourth mission of a university. But we suppose it is the first one as it gives the vector to other missions – academic, scientific and social. There can not be any integration without a cultural one. That is why we are ready to discuss new grant proposals with the idea to be the key one.

## References:

1. G.S. Tesler. New Cybernetics. – K.: Logos, 2006.- 2004. – p. 57-58.
2. D.I. Shapiro. The Virtual Reality and Neurocomputing Problems. – M.:RFK- Image Lab, 2008.
3. L.N. Melnikov. The Virtual Reality and the Space Consciousness //Delphis, №2 (46), 2006. – p.111.
4. A.P. Kovalev, S.G. Dzhura, L.V. Chernikova. Energy Risk Control (to 150<sup>th</sup> Anniversary of N. Tesla) // Proceedings of Donetsk National Technical University. Series: “Electrical Engineering and Energetic” issue 112. –Donetsk: DonNTU, 2006. – 151-153.
5. A.V. Levshov, A.P. Kovalev, S.G. Dzhura. Heading to the Solution of N.Tesla’s Phenomenon (interdisciplinary approach). Proceedings of Donetsk National Technical University. Series: “Electrical Engineering and Energetic” issue7 (128). –Donetsk: DonNTU, 2007. – p. 11-13.
6. T. Paymans. Free Energy Pioneer: John Worrell Keely //Delphis, №2(42), 4(44) 2005; №1-4(45-48) 2006; №1(49), 3(51) 2007; №2-4(54-56) 2008. <http://www.roerich.com/delfis/index.html>
7. E.P. Blavatskaia. Secret Doctrine (in three volumes) – Kharkov, Exmo Folio, 2008 <http://www.roerich.com/zip/td1part1.zip>
8. S.G. Dzhura. Social Aspects of the Internet-Communication // Proceedings “Language and Culture: Problems of the Social Communication and the Intercultural Dialogue”. Supplement to the Interdisciplinary Practical Newsletter “Man in the Social World.” Volume 6. Tula, 2003. – p. 42-51.
9. Awards of the Oriflamma Project: <http://roerich.com/award.htm/>
10. T. Davidenko. Let the Good in and it will Come Back // Vecherni Donetsk №166(8798) of 11.11.08; [http://iic.dgtu.donetsk.ua/russian/ovs/don.jpg /](http://iic.dgtu.donetsk.ua/russian/ovs/don.jpg/)
11. M.A. Basin, I.I. Shilovich. Way to the Synergonet. – StPb.: Norma, 2004. <http://www.roerich.com/zip3/synergonet.zip>

## **Conclusions**

The mankind used to move to the new technological setup. Now the new setup is considered to be spiritual and ethic one which will give the mankind new possibilities. They are, first of all, energy technologies of N.Tesla and J. Keely, the utterly new political structure which is the mankind's brotherhood. The tutorial in this case will be the Metaknowledge (Agni Yoga, THE, and Theosophy). The main goal of the evolution is to equip the man without any device. For this we should know the man about whom F.M. Dostoyevsky wrote: "The man is a mystery. It is to be revealed. If you do it all your life time, do not say that you wasted time; I learn the mystery because I want to be the man."

Machines are being replaced by undiscovered power of the man which can not be discovered without the ethic exam taken by the mankind. If the book has given food for thought the author can think his task to be fulfilled. Further development is in thorough research of the metaknowledge which gives answers to the most topical questions of nowadays. They are traditionally discussed at the conferences "Ethics and the Future Science" organized by the Delphis journal.

Our common library which is on the portal roerich.com and which was awarded the diploma of the World Club of the Residents of St. Petersburg at the State Hermitage of Russia (the Chairperson of the Organizing Committee M.B. Piotrowski invested it) helps to discover the Knowledge.

Some presentations on the book articles are attached. The video of some presentations can be seen at <https://www.youtube.com/user/dzhura77>

My deep gratitude goes to our Teachers!

Vivat, Donetsk Polytechnics!

## Selected presentations

### MULTIDIMENSIONAL CONSCIOUSNESS



S.G. Dzhura.  
[dzhura@roerich.com](mailto:dzhura@roerich.com)  
 (062) 337-32-66;  
[www.roerich.com](http://www.roerich.com)



### The paper announcement :

*The most ancient theories on man and his consciousness composition as well as modern physical ones are analyzed. The hypothesis on integration of esoteric and the world modern physical picture is argued.*

*It is the feasible contribution to the implementation of the behest of Agni Yoga on **«the ancient knowledge to be transformed into scientific formulae».***

**Agni Yoga,, Brotherhood, p. 1, 425.**







## The problem statement:

- *Human septenary consciousness and bodies in the esoteric tradition (theosophy).*
- *Three-dimensionality in Agni Yoga (the thick, subtle and Fiery worlds). T*
- *11-D modern physical theory of super strings and M-theory*

«...In fact the string theory is a part of **the grander synthesis which has a slightly mystic name now – M- theory...**»

Brian Green “The Elegant Universe”

**Брайан ГРИН**

МИРОВОЙ НАУЧНО-ПОПУЛЯРНЫЙ БЕСТСЕЛЛЕР

Грин затрагивает потрясающее количество тем, излагая их простым и ясным языком без математических выкладок и технических подробностей... Это образец научного повествования... Трудно не заразиться хоть отчасти его энтузиазмом и возбуждением

*The Philadelphia Inquirer*

# Эlegantная ВСЕЛЕННАЯ

**Суперструны, СКРЫТЫЕ размерности и поиски, окончательной теории**



**Брайан Грин**

окончил Гарвардский университет. Диссертацию защитил в Оксфорде. В 1990 г. начал работать на физическом факультете Корнельского университета. С 1996 г. профессор физики и математики в Колумбийском университете. Грин читал лекции в более чем двадцати странах, выступая как перед специалистами, так и перед широкой аудиторией. Его имя широко известно за ряд фундаментальных открытий в теории суперструн.





**Эlegantная ВСЕЛЕННАЯ**

Редкостью сочетая научное осмысление и изложение столь же эlegantное, как и объяснения, даваемые теорией, Брайан Грин срывает завесу таинства с теории струн, чтобы представить миру Вселенную, состоящую из 11 измерений, в которой ткань пространства рвется и самовосстанавливается, а вся материя от наименьших кварков до самых гигантских суперновых порождена вибрациями микроскопически малых петель энергии.

Грин использует разнообразные примеры — от аттракционов в парке до муравьев на садовом шланге, — чтобы проиллюстрировать прекрасную, однако причудливую реальность, открываемую современной физикой. Великолепная по талантиности, беспрецедентная по способности и просвещать, и увлекать, *Эlegantная Вселенная* — пример научного изложения, восхитительное путешествие по современной физике, которая как никогда ранее приближает нас к пониманию того, как устроена Вселенная.

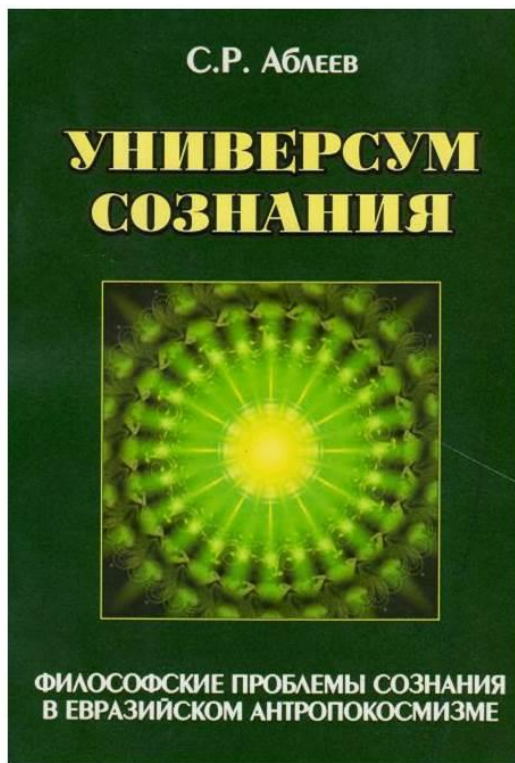

«the physical and psychic realities are connected inseparably and are just particular cases of the multidimensional complex integral space reality which is not comprehended yet»

S.R. Ableev



## What is true 7-3-11 ???

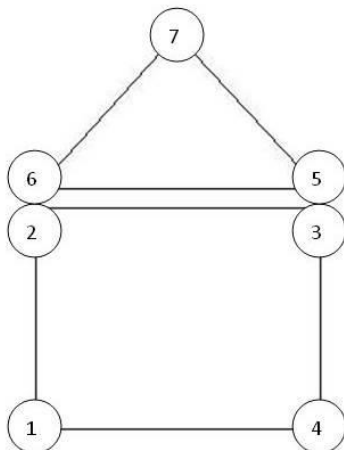

## THE IMMORTAL TRIAD



### The theosophical tradition ( explanation of E.I. Roerich volume III (1935) “About the Septenary Subdivision of the Human Body”:



1. The physical body.
2. The ether lookalike (it is called the lowest astral body). Many phenomena are made with the help of the ether lookalike of the medium during a séance.
3. Prāna – a life principle inseparable of all Space phenomena.
4. K ama – an animal soul (or the highest astral body through which two aspect wish is demonstrated):
  - a) Kama-Manas – the lowest mind or intelligence.
  - 6) Kama- Rupa – a form ( a subjective form of mental and physical wishes and thoughts or a thinker in action).
5. Manas – self-consciousness or a thinker (the Highest Mind).
6. Buddhi - spirituality, a spiritual soul – unlike the human and animal soul- a guide through which Atma appears.
7. Atma – Spirit or the Fiery origin or energy spread in the entire Space.

## The combination of the positions of Agni Yoga and theosophy



“The philosophical language The Ethics Life of Agni Yoga has the eastern terminology and the original stylistics as compared with theosophy. However, it is much simpler and more accessible than the language of the theosophical text of the XIX century as to many of its parameters. Thus the theosophical septenary system of ontological patterns of the space reality in Agni Yoga is transformed into a simpler three level model. These reality levels are called the Thick World, the Subtle World and the Fiery World.”

S.R. Ableev

## The hypothesis of combination of the multidimensional consciousness of different traditions $7 + 4 = 11$

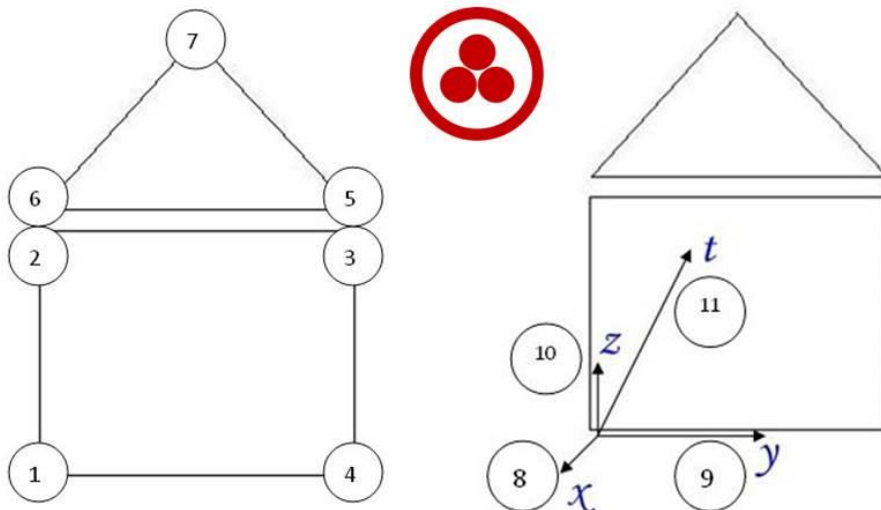



## Conclusions (1):

Thus the paper combines the world modern physical picture (the multidimensional consciousness) and the ancient esoteric doctrine. The external contradiction solving is theoretical so far and is to be tested in practice though it will be extremely difficult in the application to the consciousness. But the hypothesis does exist. It will be the small approximation in understanding of the great concept of the Consciousness that leads the mankind to the evolution. It is said not without reason that " it is the SINGLE LIFE, eternal and invisible, and at one and the same time ever-present , without the beginning and the end, but periodic in its regular demonstrations among which the Non-Being darkness rules; it is unconscious and the Absolute Consciousness, the incomprehensible but single self-essence Reality, the true Chaos for feelings and the Space for the mind. Its absolute characteristic, the continuous Motion is called the Great Breath in the esoteric language and is the ceaseless motion of the Universe in sense of the limitless eternal Space. Everything that has no motion can not be divine. But in fact and in the reality there is nothing absolutely immovable in the Universe Soul." E.P.B.



## Conclusions (2):

"The time will come when the nature hidden secrets and the Highest Knowledge which the Great Teachers own now will be accessible to all people. Those who are ahead and who are headed by the Light Lords and, of course, the Great Teachers that come to Earth from time to time and live among the people lead the mankind to it. They have the only goal which is to give the knowledge to the people in such a way for them not to abuse it. The danger of the abuse is big. They can destroy Earth. That is why only some of them who were tested during thousands of years of joint work are led by the ways of the direct cognition. Only they are trusted and the people will be given through them."

**Sides of Agni Yoga, 1957**

# THE CRUCIAL ROLE OF CULTURE IN THE NOOSPHERE FORMATION AND DEVELOPMENT



S.G. Dzhura

[dzhura@roerich.com](mailto:dzhura@roerich.com)

(062) 337-32-66;

[www.roerich.com](http://www.roerich.com)



## The paper announcement:



*The problems of choice of the mankind's development vector are analyzed. The proof of the crucial role of culture being the integral criterion of the development is given. The ways out of the world outlook crisis which is the ground for the economic one are offered. The practice of revival and development of the Institute of Culture of DonNTU is given and the crucial role of culture in the noosphere formation is grounded.*

...only a full-grown synthetic approach in science is able to reveal the signs of evolutionism in different natural processes and thus to draw the real vector of development of various objects in the Space and on Earth (under the influence of the external space factors) for all the life symptoms. It is urgent to be observed because of the growing rate of changes taking place on Earth including **catastrophic phenomena**- geological, climatic and powerful advance in the life of the planetary socium. We are living in the certain transition period which is not short and which was forecasted by the Ancient Wisdom ( in the West it is the transition from the epoch of Pisces to that of Aquarius, in the East- from the Kali Yuga to Satya Yuga, the Golden Age) ...



## The problem statement :

- The graph of the internal product and the progress real index for the USA.

Prof. A.V. Kendyukhov  
**«Economics is a derivative from the World outlook»**

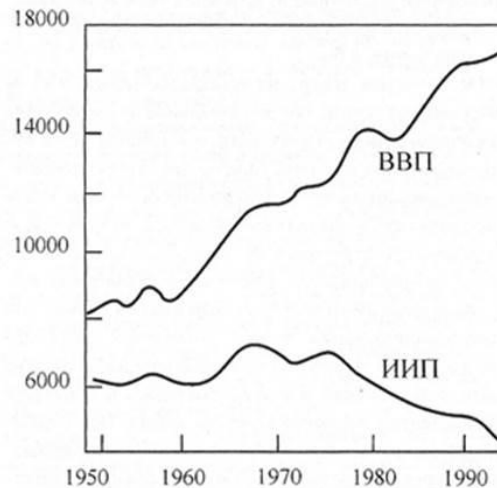

## The strategic way out through the philosophical understanding



Prof. A.V. Kendyukhov « **Economics is a derivative of the world outlook.**».

**To treat economic without the world outlook not being treated is like to reduce the body temperature without the disease being treated.**

If the priorities are not changed and the way of the mankind's development is not coordinated with the global evolutionism the result is easy to forecast just by the graph prolongation. Thus the civilization development vector is aimed at the civilization destruction. Meta knowledge proves it

...

## The symbolic statement of P. F. Belikov:



«Neither the world politics nor the world economics have ever been and will be the evolution crucial moments. The goal of the evolution is to create the man able to think by space categories rather than the man able to think correctly. The politics, economics and all social formations created by them teach the man to know the essence only on minor and temporary examples. It would be ridiculous to think that “justice” or “injustice” of these short-term forms of the human social life are yardsticks inherent to the Space Mind.»

## Meta knowledge: (Agni Yoga, THE, Theosophy:



**...The space wave can displace not only just a man, a nation or a continent but the entire race and the planet if there is the resistance that retards the evolution...**

**...everything that does not correspond to the Evolution stage dies out...**

**...At present all efforts of Teachers are aimed at solving the great world problems of education, religion, science and the state system.**



## **Globalization of economic and political system of the mankind on its way to the Brotherhood.**



...that the praised modern systems of education are harmful and mislead the youth, that thousands of graduates are not ready for life and are unable to fulfill their duty; the young people dishonour their specialities and think they are experts or become dealers. The man will be satisfied by the fruits of modern education until the current ideal of the civilization based on material values only rules. ..

We approve the approach of M. Cremo and R. Thompson stated in their work "Forbidden History": "It is devoted to the growing number of scientists and philologists who are able to risk it by their professional prestige, position and privileges for the sake of such an ephemeral substance as the truth."

## **Science as a part of spiritual culture.**



The Austrian and English philosopher, specialist in logic, sociologist and science expert K. Popper : "We should get used to understanding of science as not the "knowledge combination" but as the system of hypothesis that is guesses and anticipations which can not be grounded but which we use until they stand the test and about which we will never say that they are "true", more or less "reliable" or even "probable"."

...science is transformed from the "hypothesis cemetery" ( H. Poincare) to the true science only when it passes all methodological tests. That is why any knowledge has a right to exist." We would like to add that this concerns esoteric knowledge too...

## Education as the culture phenomenon that does not state the problem of the truth searching.



“The education modern state is reflected in theoretical and practical pedagogic and follows its methods, laws and principles. The education is the problem polyhedron the analysis of which allows to start from the main problem which is the pedagogic goal the ideals of which are not in demand now.”

That is pedagogic is secondary although its main function is to look for the truth and therefore it is to be leading and is to lead the civil society to the Truth. The rider and the horse exchange places and the lowest tries to rule the highest. There is the world outlook crisis. Unfortunately, profit, business and the social order but not the truth cognition are coming to the foreground. (L.M. Gindilis).

## Education or education services? The science objective function.



As the goal of any scientific process can be described in terms of the optimization theory ( as the goal must be obtained in the optimal way) the scientific problem can be considered to be the objective function OF (in the general case it is a multicriterion one with its weight coefficients) in the limit sphere (Lim – financial, temporal, etc).

$$\left\{ \begin{array}{l} F(x, y) \Rightarrow \min / \max : (OF); \\ x \leq LIM \leq X : (LIM) \end{array} \right.$$

The pedagogic task of a university is to define the level of the expert qualification characteristic (knowledge and skills). It is the objective function of the university staff in the frameworks of limits (time, the program capability, psychological and pedagogic characteristics of the listener who is able or not to get the knowledge).

Prophecies of the great (is not it about nowadays?)



The goal of learning is not just the amount of knowledge but the “correct way of thinking” and moral upbringing.

M.V. Lomonosov



«It is the knowledge quality but not its amount that is important. You can know very much but might not know the most important things.»

L.N. Tolstoy

## The crucial role of culture.

- E.I. Roerich wrote in her letter of September 5<sup>th</sup> 1935: “The civilization forced out the concept of Culture and many do not understand that you can be a civilized barbarian. They do not take into account the fact that the Culture layers are accumulated within ages but the civilization can be created within the period of ten years.” /18/ It is interesting to note that the point of view agrees with the conclusions made by ancient philosophers who can not be esotericism followers.
- José Ortega y Gasset : “The current situation gives birth to cruelty for the aftereffects of which Europe is paying now. The reason for the modern European catastrophe is that and English, French and German doctors are uncultured, they do not have the life system of ideas about the world and the man that corresponds to the present time. This average man is a barbarian lagging behind his epoch; he is archaic and primitive as compared with the horrible present and its problems. This new barbarian is a professional who knows much more than ever. But he is a lawyer, and engineer, a doctor, a scientist who is much more uncultured...”

## Let us not be science barbarians



- F.M. Dostoyevski: "...semi-science is the most awful ever known evil of the mankind . It is worse than devastator , starvation and wars. The semi-science is a tyrant that has never appeared before. It is the tyrant that has his own slaves and priests. It is the tyrant worshiped to with unbelievable love and superstition, the tyrant the science trembles at and indulges shamefully." /20/ The thesis of Socrates is extremely important for pedagogic : "There is only one good which is knowledge and only one evil which is ignorance." Stephen Hawking who is working at the department of the University of Cambridge which I. Newton used to head develops the thought of F.M. Dostoyevski: "The main enemy of knowledge is not ignorance but the knowledge illusion."
- José Ortega y Gasset : "Let us not be the science barbarians. Science is the great human achievement; the human life itself which makes the science possible is above it. In this case the breakage of elementary life conditions is impossible to make up." /19/ Today the wishes and desire of many people are directed to Europe although both exoteric and esoteric traditions noted there was no future of Europe.

### The idea practical realization (2):



- 
- Sergey Sloyoni, Maxim Romanovski and his band "The Rainbow Echo", the group "Silence Point" (Donetsk), the Zolotukins brothers (Lugansk), the group "Avakara" (Sochi) performed at the Institute's meetings..
- There also were the meetings devoted to Skryabin, Mozart, Rakhmaninov, Schnittke, , Bach, Chopin, Prokofyev...
- The documentaries "SOS" and "The Common Safety Synthesis", the film devoted to V.V. Puck that started the series "The Outstanding Scientists of Ukraine" were made on the order of the Institute of Culture and their first night was at the meetings.
- Donetsk poets E. Baranova, B. Belash and V. Kalinichenko represented the poetic area.
- The theatre area: the studio Sophiynist and theatre studio "The Fifth Wheel".
- The exhibition area: the exposition of the reproductions of paintings " Time Link: from Leonardo da Vinci to Nikolay Roerich" and "The Man, Earth and the Universe", "The Beauty Way".
- Two contests of school compositions "Why is Every Country to Preserve Cultural Treasures?" were organized.



## Conclusions (1):

The paper shows that the highest form of the knowledge – wisdom – is of maximum use. “The wisdom of ages is in the words of Jesus: “Thy will be done.” /8/ The vector of development of this Supreme will ( the evolution) is given by Culture. Its criterion is the truth and beauty is its esthetic expression. **The main goal of man is not economic, it is the ethic one that is development of the inner man.** If mankind remains ignorant in the field it will have the fate of Atlantis and Lemuria. Today the mankind is given the Gnostic sources which compose the idea of Culture: Agni Yoga, THE, Theosophy. It is them that offer the keys to understand the culture as the synthesis of religion, science and art. The Gnosis reads: “The opinion of the Teachers on the literature creativity state in the mankind is interesting. They say that the traditional literature has practically reduced itself in the person of Tolstoy and Dostoevski and confessional works that are documents fixing various experience in the unity of the Spectrum of the Entire Life are of interest for the future.” /24/.



## Conclusions (2):

Thus the gnosis ( esoteric literature) gives a new level of the knowledge which is to be assimilated and applied to the spheres of culture in life. The warning about the destruction of culture is symbolic as there is no future for the mankind as a whole without the culture: “ Previous ages people could accept or reject parts of the Great Doctrine given to them. Now when powerful energies are at the expense of people the rejection might cause the culture destruction. Atlantis died because of the Knowledge abuse. The catastrophe was partial. Today the entire planet is under the threat of the destruction as all the mankind grown in its number is involved in the orbit. The problem of acceptance of the Doctrine is the matter of life or death for everybody and everything. The hydrogen bomb can be followed by another one which can cause the matter decomposition the dissemination of which man killers are unable to foresee. Life new forms are to replace the old and obsolete. The chance of any war is to be absolutely impossible The New Sky of labour and construction and collaboration of all the nations living on Earth is to be above the planet. Our Hand is over the new forms of people's life . The short-sighted consciousness might think them to be imperfect. But the country is new and it heads the new world which will win. The new forms of social and state life will rule on Earth. There is rescue in them. Victims are inevitable. Not a single evolution was made without the victims and death of forms doomed by it to destruction. Look at the life wider. Give the new its due. The builders often do not know the greatness of the Great Plan, but the Lords do.”

## Human-and- machine analogies to understand the Truth



A.V. Levshov, S.G.  
Dzhura, V.I.  
Chursinov.

[dzhura@roerich.com](mailto:dzhura@roerich.com)

(062) 337-32-66;

[www.roerich.com](http://www.roerich.com)



### Software technology evolution (history and the forecast)

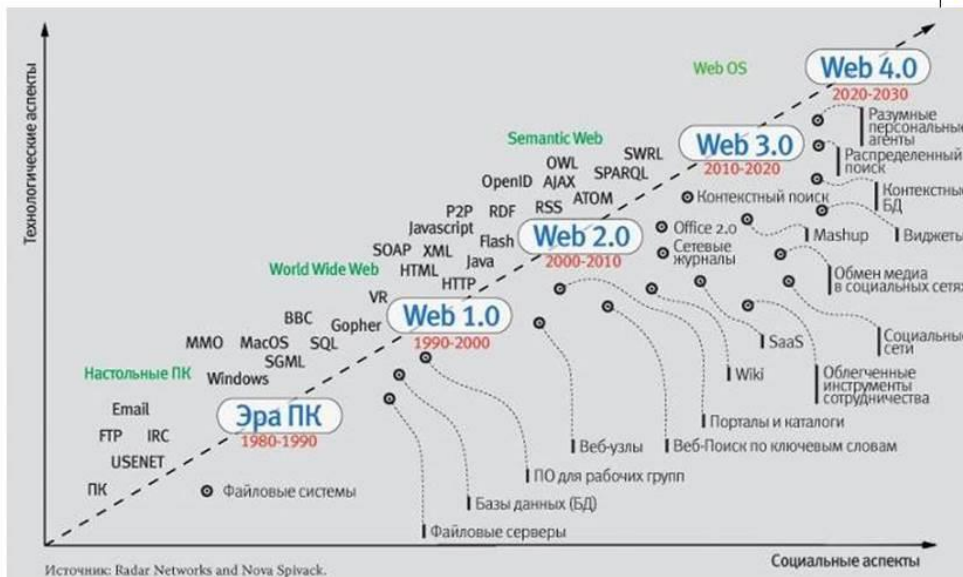

## Review of the outlooks of development of information technologies (Internet):



- WEB:
- 0 – text anticipation;
  - 1 – a person gets the text;
  - 2 – the person creates the text;
  - 3 – the community creates the text;
  - 4 – the text creates the person;
  - 5 – the text creates the text;
  - 6 – what do we need the person for?

The dead-end is present. The way out is in metaknowledge as the “earthly wisdom is abuse against God” and the wisdom of the above world is opposite to that of the terrestrial one. The answer is in the “Space Legends of East”: “The spiritual consciousness lags behind the physical knowledge. Ethics has been lost among formulae. Machines distracted man from the art of thinking. There are enough robots! We need the heart for the world balance. This order has an urgent rescue. There will be many people in the New Era who will replace the most complicated devices. Now the robots are being invented but the forces inside the man will be paid attention to when the mechanical fever is over. The man has always been afraid of everything which is mystic. He forgot that the key to Sesame was in himself.”

## Technical invention forecast :



Was forecasted	Year	Author and work
Computer	1726	D. Swift “Gulliver’s Travels”
Rocket, space flights, launching on the Moon	1867	J. Verne “From the Earth to the Moon”
Robot	1920	K. Capek “R.U.R.”
Total control over the personality	1920	E. Zamyatin “We”
The Universal shadowing in the Net	1949	G. Orwell «1984»
Electron calculator	1951	A. Azimov “Foundation”
Player	1953	R. Bradbury “Fahrenheit 451°”
The mobile phone	1953	R. Heinlein “Assignment in Eternity”
The Internet, the virtual reality	1960	S. Lem “Summa Technologiae”



## The evolution goal:

- “The world politics or economics have never been and will never be the crucial moments of the evolution. The goal of the evolution is to create the person able to think by space categories rather than the person who is able to think politically correctly. The politics, economics and the social formations created by them teach the man to understand the matter only on minor and temporary examples. It would be ridiculous to think that “justice” or “injustice” of these short-term forms of man’s social life are typical to the yardsticks of the Space Intellect.”
- The goal is to equip the man without any device as all the devices which are more perfect than any other mechanical facility are in him in their potential. Understanding of the fact will open new ways for the search and possibilities for new amazing achievements. All the inventions and devices created by the human genius are in demand until his own device starts operating in its full force. The statement is explained by the fact that there are no plants, factories, machines and devices on the far planets of the high level. The life in its phases is controlled by the creative thought and the spirit energy. Everything the man needs for his life is obtained by the creativity.



## Why metaknowledge?

Forecasts are science prerogative. The possibilities of the science are limited. It is impossible to give a correct weather forecast for a month. The reason is that every scientist knows the limits of his competence and the science tool is limited too. The Russian scientist and encyclopedist L.V. Leskov writes: “ First, scientists were unable to forecast any of the large turns in the world history of the XX century. Second, the number of strategic system errors had grown in some countries, for example in Russia, by the end of the century. The payment for this was too high. The scientists failed to give early convincing proofs of the strategic solution invalidation to the decision makers.”

The predictions of various prophets speak about the invention of the robot that will totally replace the man and most likely will form the future army. It is sad. The understanding of the results of inventions of the mankind lags behind the inventions for ages and it creates risks for the mankind’s existence. The invention of the robot-soldier might cause understanding of its danger and allow the mankind to avoid the trap of the terminator created by the man. The situation has been used in science fiction and films not once.



## Graph of growing computer capacity and reduction of the benefits ( a paradox).

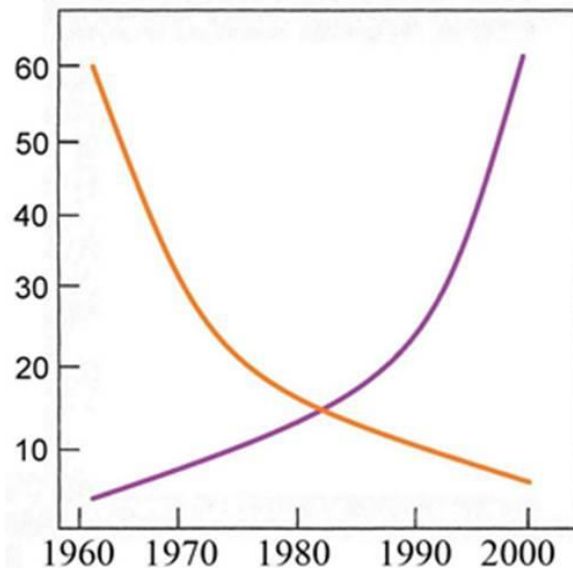

## The traditional science in a theoretical crisis

1. The All-Russian conference of young researchers "Artificial Intelligence: a Philosophy, Methodology, Innovations" takes place in Moscow. The presentation made by Prof. Yasnitski (Perm) "Neural Network Technologies as a Method to Get New Knowledge" was paid great interest to and caused active discussions at the "Round Table" meeting. It summarized the practice of creation and application of intellectual systems in industry, economics, sociology, political science, ecology, medicine and criminal science. The neural networks revealed new scientific and engineering knowledge that provided high accuracy in diagnostics, forecast and optimization of the modeled processes and phenomena. The speaker noted that some of the knowledge was immediately recognized by the scientific community ( for example, the project E-ESULAP in medicine). Some new laws were explained from the materialistic point of view only after some long discussions with specialists. Some of them still can not be explained in the frameworks of traditional scientific theories. The participants of the presentation discussion recommended the speaker "not to mix the official science and esoteric." However, the majority of them agreed that "the modern scientific world was less orthodox" and new knowledge and facts even though they were not in the frameworks of the generally accepted scientific knowledge were to be published as a discussion subject-matter" as their application under the development and implementation of the intellectual systems led to significant practical results. The slogan on the wall of the conference hall proves it: "Do not take our results seriously as astrology is in the black list in struggle with pseudo-science at the panel of the Russian Academy of Science." However, many lances were broken over it.



## Conclusions (1):

The statistics and thoughts given in the paper prove the idea of A. Vladimirov: "The scientific and technical revolution is to be replaced by the scientific and spiritual one that liberates the mankind from the total technocratic dependence and gives the man his real prior place on the planet and the idea of the human being." The coming Union of Russia, Ukraine and Belarus ( and not only them but we do remember the behest of St. Sergiy on the backbone) is to take the atheistic curb off the science and discover new dimensions, new metals and new spatial energy. Russia (and Ukraine being its part) is to show a new spiritual culture, new all-triumphant beauty, and the harmony of the spiritual and the corporal. Russia is to show the union of religions based on the reality and many-sided Above-the-Ground being, to consolidate the mankind's spiritual energy on the Hierarchy. Russia is to build a bridge for the constructive collaboration among the mankind and the far worlds. For the miracle of the new possibilities to come true Russia is to be the centre of the future planetary Community. It is followers of the Roerich's ideas and the organizations that support them that are to be ahead of the New World and to be its pioneer! My friends, let us unite to build the New World!



## Conclusions (2):

The information is not only a creative but also a destructive phenomenon of nowadays. Where is the end of the " misfortune caused by the mind", where does the information become useless and change its sign to the negative one? Once Plato thought the **ideal city** to have **5040** inhabitants. That is there was the optimal number of inhabitants for the city. That is why we think that we should also speak about the optimal amount of the information. Then it will do good. What is more than that is that S. Lem says in his book "Summa Technologiae" /27/. One of its chapters is called "The Megabit Bomb". Isn't the Internet such a bomb? We see the criterion in the metaknowledge which is given in the book "The Heart". It is the development of the heart of every person that can prompt where the boundary is. We are to develop the inner man inside of us. All the message of the metaknowledge is aimed at it /8/: "Our goal is to equip the man without any device as all the devices are in the man's microcosm. The lagging behind is in the fact that the process of opening of all **centres** and perception sophistication is safe only under removal of any sweeping from the consciousness. Otherwise the danger and man's destruction are inevitable. If the consciousness lags behind, even scientific discoveries are dangerous and might cause mutual destruction. That is the most important and urgent task is to transform the consciousness. The task is extremely difficult. It is easier to move a mountain than the stony consciousness. The consciousness state depends on the heart. Let us knock at the human hearts to awake the spirit. People are to wake up and put a veto upon the governors who plan wars and other desperations. The New World will not win on the planet without conscious help of nations and it will be established despite the will of the governments that lead the mankind to the destruction. The world situation is extremely intense."



ПОЧЕТНЫЙ  
ДИПЛОМ

ОРГКОМИТЕТА  
МЕЖДУНАРОДНОЙ ПРЕМИИ  
ИМЕНИ НИКОЛАЯ РЕРИХА

НАГРАЖДЕН

*Дажура  
Сергей Георгиевич*

В НОМИНАЦИИ

«СОХРАНЕНИЕ РЕРИХОВСКОГО НАСЛЕДИЯ»

PAX CULTURA

Учредители:

Всемирный клуб петербуржцев  
Санкт-Петербургский государственный университет  
Санкт-Петербургский государственный Музей-институт семьи  
Рерихов  
Санкт-Петербургское художественное училище им. Н.К. Рериха  
Международный благотворительный фонд «Рериховское наследие»

Председатель Оргкомитета

*М.Б. Пиотровский*

М.Б. Пиотровский

07 октября 2008 г.

**The book review**  
**“The Universe Ethic Algorithms”**  
**The author – Sergey Georgievich Dzhura,**  
**Candidate of Science, Doctor of Philosophy,**  
**Director of the Institute of Culture**  
**of Donetsk National Technical University**

S.G. Dzhura's work deals with the range of topical issues of the modern science and spiritual culture. It is a collection of papers having the general idea of understanding of the synthesis of physical laws of the nature and spiritual algorithms of the being. The author tries to overcome inertial theoretical tendencies of the old science and be guided by unorthodox philosophical ideas which are under keen discussion in the academic world. The attempt to find and give the rational representation of implicit correlations of ethic metaphysics of the past and achievements of the modern scientific knowledge is certain to be worth of great attention and support.

The book deals with the great number of various problems which are in the zone of the interdisciplinary synthesis which intends to attract the philosophical concept, empiric natural science and ethic thought. Unfortunately, this anti-positivistic approach faces considerable resistance of apologists of the obsolete paradigm of the scientific rationality. However, the approximation of the world outlooks of scientific and religious and metaphysical knowledge meets the spirit of the new epoch in which the moral weakness of science is to be compensated by the power of the ethic thought and empiric drawbacks of the moral metaphysics are to be made up with the developing methodology of the rational science.

The author is absolutely right emphasizing the impossibility of implementation of the necessary ecological imperative in the modern world without strengthening of the moral one. It is certain to have the main ideas of the Sermon on the Mount and fundamental ethic norms of the world religions. This causes keen attention to the traditional and new ethic thought, the tendencies of new pedagogic and spiritual culture.

The book is written in a popular and rather a bright language and might be of interest for not only researchers but also for the general cultural

public that is interested in the problems of the modern civilization development.

**S.R. Ableev**

*Doctor of Philosophy*

*International Non-governmental Association “Ethic and the Future Science” (Moscow)*

**The book review**

**S.G. Dzhura**

**“The Universe Ethic Algorithms”**

The books that reveal mysteries of the Universe published recently are rare. It is not a surprise that the book under review aroused lively interest. We can find statement of some traditional and new problems solving of which places cosmogonical and practical knowledge on a new level.

This combination of lofty cosmogonical ideas with practical aspects of the modern science is, from my point of view, the main merit of the book. The author managed to combine the loftiest cosmogonical ideas with the development of the topical problems of philosophy and pedagogic.

Being an expert in pedagogic, I am especially interested in pedagogic algorithms and their implementation. The author’s approach to the analysis of philosophical grounds of the modern pedagogic is new and original in many aspects. The modern philosophy is complicated and non-uniform. It remains the methodological basis of pedagogic. What basis it is, is the question. S.G. Dzhura tries to solve the problem and we might agree with his arguments. Practical implementation of his approach is made through distance learning the theory and technologies of which have much new and original. The distance learning of the future, approaches based on the retrospective analysis of a philosophical thought, characteristics of the distance learning at the development noospheric stage, outlooks of application of artificial intelligence in the distance learning, energy and information paradigm of the distance learning and other methodological and theoretical problems are examined. The foundations of the pedagogic of synthesis sorted out by the author and with the help of which our science will be able to make a compact and demonstrative presentation of its

theories are important. I would also like to promote the author's attempt to use neural networks and artificial intelligence tools to improve the distance learning system.

In a word, it is an interesting scientific book which is a result of work of the author and his like-minded the names of which are given and their contribution is not minimized. The work ahead is large. It is to be noted which audience the book is meant for as the title might not attract pedagogues who did not get used to combine their everyday problems with the universe algorithms. It is also advisable to make the move from the space ideas to the vital problems of nowadays smoother.

***I.P. Podlasy***

*Doctor of Pedagogic, Professor, the international expert in education*

### **Book review** **“The Universe Ethic Algorithms”**

The book under review is the inter-disciplinary research which is quite a rare case at present. New discoveries are known to be made on the science joint. The book analyses the outlooks of development of four scientific fields: electrical engineering, pedagogic, artificial intelligence and philosophy. I think that the experts in them are to review the book. All the fields are examined in the context of the developing meta-science. I would like to dwell on the electrical engineering and its promising links with other sciences.

The author examines the latest tendencies and outlooks of the change of paradigms in the electrical engineering and introduces some concepts such as “synthetic electrical engineering”, “meta-electrical engineering”, “quantum electrical engineering” and “multidimensional electrical engineering”. It deviates from the frameworks traditional physics (though it is discussed at a number of international conferences) and, according to the general classification, refers to meta-physics and even to hyper-physics. However, the approach examines the science in its dynamics that is the

developing science of Thomas Kuhn described in his work “The Structure of Scientific Revolutions” in which he says that the change of paradigms, and the world outlook in particular (in our case it is a move from the visible to the invisible), is a norm for science. This process has been going on with the help of devices for a long time but the boundaries have not been reached yet due to natural reasons.

The second aspect which speaks in favour of the approach of the author of the book is in the result of the theorems of Gödel that reads that “any complicated system is inherently conflicting (1) and incomplete (2). As the electrical engineering matches the characteristic, the approach of S.G. Dzhura is interesting at the minimum. Time will show whether he is right or not. I can say that the approach at least does not contradict basic propositions and fundamental concepts of physics as a science. The search of new fields of the future development is always interesting as it allows discovering and discussing the outlooks. The one who knows the future will own and rule it.

In a word, it is an interesting scientific book which is a result of work of the author and his like-minded the names of which are given and their contribution is not minimized. The drawbacks of this serious work are little specification of the fields the author writes about and small experimental material (if compared with the theoretical one). This requires the work of a team if not of the entire institute. The author deals, by the highest standards, with strategic problems of the mankind’s development. Their solving is the subject-matter of institutes of strategic research of different countries.

Despite the drawbacks the book can be recommended to the wide audience that is interested in the latest achievements of science and its integral examination from different sides and defining of its position in the context of building of the future science.

*V.A. Goltsov, Doctor of Science (1973), Professor (1975), an academician of the International Engineering Academy(1990), a member of the Board of Directors of the International Association of Hydrogen Power Engineering (the USA), the Head of the Department of Physics of DonNTU, the Education Worker Emeritus of Ukraine.*

**Book review**  
**S.G. Dzhura**  
**“The Universe Ethic Algorithms”**

According to the paper of the Indian spiritual leader Osho “The Golden Future” the present world situation is “the global suicide”. He sees the way out in the world global reconstruction: the abolition of nations and religions, establishment of the World Government that have little to do with any politics which would lead the collapse of territorial and religious claims, and, as a result, wars.

Every person has its own idyll of “the golden future.” The author of the book “The Universe Ethic Algorithms” also has his own point of view on the future of the mankind. If Osho’s future is the utopia, S.G. Dzhura’s opinion is quite specific: the ethic aspect of the modern scientific paradigm is to be regarded of paramount importance for the mankind’s evolution development and the accumulated esoteric knowledge should be considered in the light of philosophy.

We live in the information society. “The amount of snow-slips that covered the man in the XXI century deforms traditions and aims and changes the idea of the Truth. We have approached not only a new millennium but also the civilization turn which requires a new way of thinking” (N.N. Moiseev). What kind of thinking is it to be? “The absence of the information usefulness criterion” (V.V. Puck) causes the harmful influence of the consumed information. What will be able to clear people’s minds from the information mishmash in which religious fanaticism and unbelief, knowledge and ignorance, lofty wishes and moral bankruptcy dressed with “spicy sauce of vulgarity and cynicism” get on? How can the consciousness pick the necessary paints out of the information variety palette? The network gives any information “to order”. “The propaganda is getting meaner and taking the soul and brains away more and more often.” (Y.M. Klyuchnikov). P.A. Florenski said: “Man assimilates to what he sees.” When the TV appeared people started saying: “A man is know by the TV programs he watches.” V. K. Zvorykin, the founder of the modern television, complained of the program vulgarity and said he would have never created the TV if he had known what programs would be broadcast.

But the technical progress is impossible to slow down. What do the youth watch? What thoughts do they enrich the noosphere with? The Internet as the noospheric component is filled with the information of questionable value which, however, does not belittle its merits. The modern civilization with its information and facilities threatens human psychic health. The supposition of the half of the mankind being ill in psychic



diseases was stated at one of the symposia of the World Organization of Healthcare during the Soviet period. They spoke about soft symptoms of the diseases. The XX century and nowadays are thought to be the most nervous in the history of the mankind. Can a nervous man have positive thoughts? What do we fill the atmosphere with?

“The noosphere was created in the epoch when the human thought enveloped the biosphere and is changing all the processes”, - said V.I. Vernadski. He analyzed the possibilities of the civilization growing power and made the conclusion that the mankind’s future depended on the active interference of the Mind into the fate of the society and the noosphere. The transition of the biosphere into the noosphere is to be accompanied by a new behavior of people, new ideals and moral qualities. The author of the book “The Universe Ethic Algorithms” emphasizes that the human moral values are to dominate in the noosphere epoch. The noospheric civilization is to fulfill the evolution mission and therefore we need to have enlightenment in the human mind.

Esoteric knowledge which both religion and orthodox science are going on to deny could be of help. Many people consider esotericism to be either “mind extremes” of the intellectuals or activity of the frauds. The average man will hardly ever doubt the truth of incomprehensible phenomena and he hardly knows that “the culture grew from mystic experience” (N.A. Berdyaev).

Hermes Mercurius Trismegistus who lived in the 2-3 millenniums BC is known to be the founder of the esoteric doctrines. All the sciences grew from esotericism. Religions appeared, and science was developed, philosophy tried to interpret the science (science philosophy) and religion (theosophy).

But all was in vain: they did not approach the true understanding of the world. “It does not matter what the origin and reasons of religious beliefs are. It matters to what degree they can claim to the truth.

Religion and science are two methods to explain one and the same reality,” S. Frank writes in his work “Religion and Science”. Esoteric knowledge which has fallen into oblivion for so long can “claim to the truth.” “Development of the modern scientific paradigm is impossible without esoteric concepts which are to be included into it,” the author of the reviewed book thinks. He is absolutely right, as religion, science and esotericism are to be combined on their way to the Truth.

It is good that many of people think over the books of E.P. Blavatskaya, E.I. Roerich, D.L. Andreev, G.I. Gurdzhiev, R. Steiner, Jiddu Krishnamurti, Sri Aurobindo and Rajneesh (Osho). The books and publications in which the authors speak about the multidimensional

Universe and consciousness, about their unboundedness and the information and energy nature, that is the things which S.G. Dzhura speaks about, are impressive. The thinking person is not satisfied with the world old paradigm. “If we do not see anything and if this “anything” can be neither proved nor confirmed, it does not mean that it does not exist.” The idea is traced by the authors, S.G. Dzhura being among them, who were brave to tell their readers about it. “It is impossible to prove that the phenomenon is missed, we can only state that it has not been discovered” (A.B. Migdal). “Science is to deal with what cannot be. The thing which can be is not science, it is a technology” (P.L. Kapitsa).

There is an esoteric textbook “Introduction into Esotericism” written by V.L. Nazarov (Moscow, 2008). If the textbook was published, it means that someone risked it to introduce esoteric knowledge into training. The fact answers the proposal of S.G. Dzhura to introduce the course “The Modern World Outlook” the task of which would be to form modern thinking among the youth.

The idea of the new noospheric policy is to give people the access to the knowledge which lightens the way to the Truth. “Limitation of the knowledge by a small group of people weakens the human philosophical spirit and leads to the spiritual impoverishment” (A. Einstein). All the problems are caused by the “immature mind”. N.K. Roerich was sure that the “source of all the problems in the world is ignorance.” It is the main argument in favour of introduction of the course on the world outlook. The author of the “Universe Ethic Algorithms” pays readers’ attention to inadmissibility of the half-hearted education in which its humanitarian part is not represented enough or is ignored at all. We are on the eve of the new scientific revolution when the esoteric knowledge makes significant corrections to the outlooks of the orthodox science.

S.G. Dzhura touches upon the topical issues the mankind is facing today. These are energy problems which are closely connected with ecological ones. Science has entered the epoch of introduction of ecology. Now it needs humanitarian and social expertise of scientific programs. The call of the author of the book to create a new energy epoch is rather logical. The ecological purity of energy is possible on the principles developed by N. Tesla. “The outlooks of power engineering are great. The root of the future discoveries is to be looked for in multidimensional energy and its highest dimensions,” says S. G. Dzhura. But the mankind is not ready yet, its moral level is not sufficient to go the way seen by N. Tesla. It is an ethic problem. “The knowledge in application of the highest dimensions is the

sphere which can be overcome by the man having the outlook of the noospheric development stage” (S.G. Dzhura).

The author of the book under review is master of the method of artificial intelligence, the neural network technologies in particular. Many researchers are keen on the young but rather promising technologies. However, very few of them, unlike S.G. Dzhura, were able to see that the ability of the neural networks to get new scientific knowledge could be the element which would combine esotericism with orthodox science (L.N. Yasnitski).

The pedagogic aspect is sure to play a significant role in the human evolution development. The author thinks that the education paradigm is to be changed. It is to be energy and information. According to S.G. Dzhura the new noospheric education is to be built on synthetic pedagogic which includes evolution, energy and information and meta-pedagogic. Although Prof.V.V. Puck from Donetsk National Technical University says that pedagogic is a forced science the discussion about it is to be continued.

The book of S.G. Dzhura “The Universe Ethic Algorithms” is based on the analysis of the large amount of books, papers, conference presentations. It is great many years’ work in which the author gives his understanding of the outlooks of the mankind’s evolution development. The book is aimed at a prepared reader and the “not prepared mind” will not take it. However, we need it and it is of great value as it makes us think of the “mystery of the human being which is not in just living but in what we live for” (F.M. Dostoevski).

### **Reviewers:**

*L.N. Yasnitski, a professor of the Department of Applied Mathematics and Informatics of Perm State National Research University, the Chairperson of the Perm Department of the Academic Board of the Russian Academy of Science in Methodology of Artificial Intelligence, Doctor of Science.*

*T.V. Danilevich, a Senior Lecturer of Perm State Humanitarian and Pedagogic University.*